

Flow switch for liquid media



flow-captor 412x.40M/.41M S141

The flow-captor 412x.40M/.41M S141 is ideally suited for use in automation processes or other industrial applications where liquid media must be monitored. The sensor operates according to the calorimetric measuring principle, fully electronically and without mechanically moving parts. The flow-captor records the flow velocity of the medium and converts it into an electrical signal.

- precise switching flow monitor with **relay output** for water or oil based media **up to 100 bar**
- version with **BINDER coupling (S141)**
- high switching accuracy even with slower flows
- separate setting of set-point and range
- display of the flow and the adjusted set-point via LED chain
- LED for switching status
- robust stainless steel design (special potting)
- ISO 9001:2015



Control and display panel

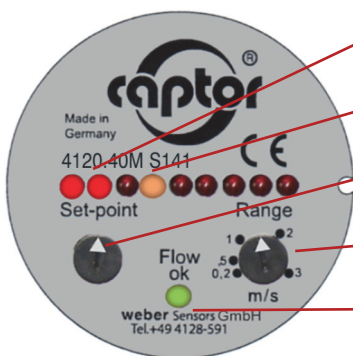

- LED-chain for display of flow range
- Flashing LED for display of adjusted set-point
- Potentiometer for flow set-point
- Potentiometer for adjustment of measuring range from .2 to 3 m/s
- LED for display of output status

Example of operation

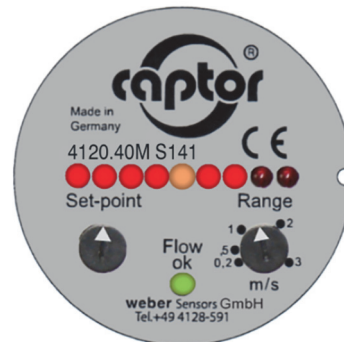

- Measuring range adjusted to 3 m/s = 100 % (9. LED)
- Set-point adjusted to 50 % of end value (5. LED)
- Flow speed equates 75 % (7. LED)
- Green LED is **ON**: Flow rate is above the adjusted set-point.

1/2" BSP thread standard size



The flow-captor 412x.40M/.41M S141 is available with different sensor head versions.

- 1/2" BSP thread – standard size –
- Extended sensor probes with 1/2" BSP thread are available
- NPT thread as option

Sensor heads

The sensor head is constructed of only one piece of electropolished stainless steel and without any sensor element intruding into the medium. Easy installation by means of T-piece or welded fitting.

For aggressive media special materials can be offered. The electronics inside is completely epoxy resin encapsulated.

flow-captor 412x.40MK/.41MK S141

Cooling version with heat sink for medium temperature up to 130 °C

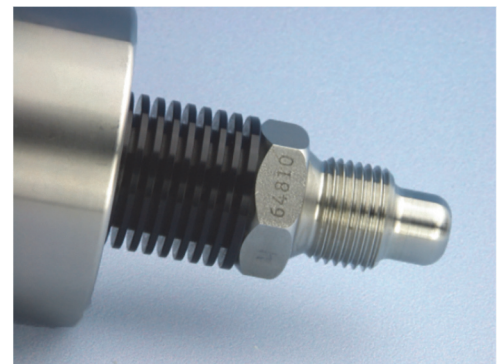

weber

Sensors GmbH Strohdreich 32
Sensors Ltd. 66 Eastbourne Road, Southport
Sensors LLC. 4462 Bretton Court, Building 1, Suite 7

DE-25377 Kollmar, Germany Tel.: +49 (0)4128 - 591 · Fax: - 593
Merseyside PR8 4DU, UK Tel.: +44 (1704) - 551684 · Fax: - 551297
Acworth, Georgia 30101, USA Tel.: +1 (770) 592 - 6630 · Fax: - 592 6640

www.captor.de
info@captor.de
sales@captor.co.uk
sales@captor.com

Flow switch for liquid media



flow-captor 412x.40M/.41M S141

Technical data		
Type	4120.40M/.41M S141	4121.40M/.41M S141
Media	water-based	oil-based
Sensor data		
Measuring range	0 - 20 cm/s to 0 - 300 cm/s, continuously adjustable *1	0 - 30 cm/s to 0 - 300 cm/s, continuously adjustable *2
Set-point range	approx. 15 % - 90 % of range setting	approx. 15 % - 90 % of range setting
Medium temperature	-20 °C to +80 °C	
Ambient temperature	-20 °C to +70 °C	
Pressure	max. 100 bar (1450 PSI)	
Response time	2 sec. - 10 sec. depending on range setting	2 sec. - 15 sec. depending on range setting
Linearity deviation	< 5 % *1	< 5 % *2
Repeatability tolerance	< 2 %	
Hysteresis	approx. 10 %	
Temperature drift	< 0.3 % K	
Mechanical data		
Protection class	IP67	
Material of housing	stainless steel AISI 303	
Material of sensor probe	stainless steel AISI 303 (other material on request)	
Sensor probe sizes		a) flow-captor 412x.40M/.41M S141 BSP Length 30 mm, 1/2" BSP
(A): Sensor head AISI 316		b) flow-captor 412x.40MA/.41MA S141 S110/45 BSP Length 45 mm, 1/2" BSP
(S110/xx): Length from hexagon bolt to sensor tip		c) flow-captor 412x.40MA/.41MA S141 S110/67 BSP Length 67 mm, 1/2" BSP
		d) flow-captor 412x.40MA/.41MA S141 S110/90 BSP Length 90 mm, 1/2" BSP
Electrical connection	6-pin BINDER coupling	
Connection cable (optional)	2 m PUR cable with BINDER coupling type 4923	
Electrical data		
Operating voltage	18 to 30 VDC, incl. residual ripple	
Switching current	≤ 5 A (120 VAC), ≤ 3A (250 VAC), max. 5A 150W at VDC	
Power consumption	approx. 1 W	
Circuit protection	reverse polarity, short circuit and overload	
Ready to operate	approx. 10 sec. after applying the operating voltage	
Electrical output		
	412x.40M S141	412x.41M S141
Switching condition with flow < switching point	energized, relay activated	currentless, relay not activated
LED	off	off
Switching condition with flow > switching point	currentless, relay not activated	energized, relay activated
LED	on	on
Cooling version – temperature data		
Type	412x.40MK/.41MK S141	
Medium temperature in relation to ambient temperature	Medium temperature max.	Ambient temperature max.
	130 °C	30 °C
	120 °C	40 °C
	110 °C	50 °C
	100 °C	60 °C
	90 °C	70 °C
	Medium temperature min.	Ambient temperature min.
	-20 °C	-20 °C
-30 °C	-10 °C	

*1 related to water

*2 related to insulating oil type "Shell Diala S4 ZX-I"

weber

Sensors GmbH Strohdreich 32
Sensors Ltd. 66 Eastbourne Road, Southport
Sensors LLC. 4462 Bretton Court, Building 1, Suite 7

DE-25377 Kollmar, Germany Tel.: +49 (0)4128 - 591 · Fax: - 593
Merseyside PR8 4DU, UK Tel.: +44 (1704) - 551684 · Fax: - 551297
Acworth, Georgia 30101, USA Tel.: +1 (770) 592 - 6630 · Fax: - 592 6640

www.captor.de
info@captor.de
sales@captor.co.uk
sales@captor.com

Technical data subject to alteration! Rev. AG 14.03.19

Flow switch for liquid media



flow-captor 412x.40M/.41M S141

Connection diagram

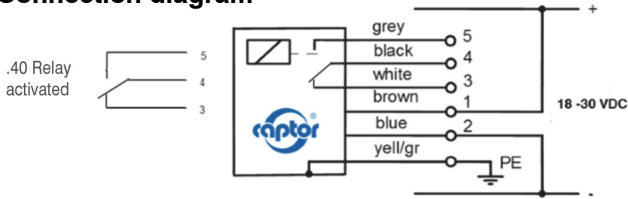

Connection diagram

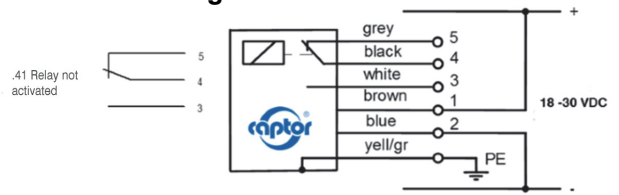

Binder Plug

Binder Coupling

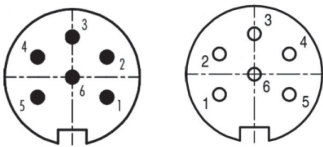

Dimensions in mm:

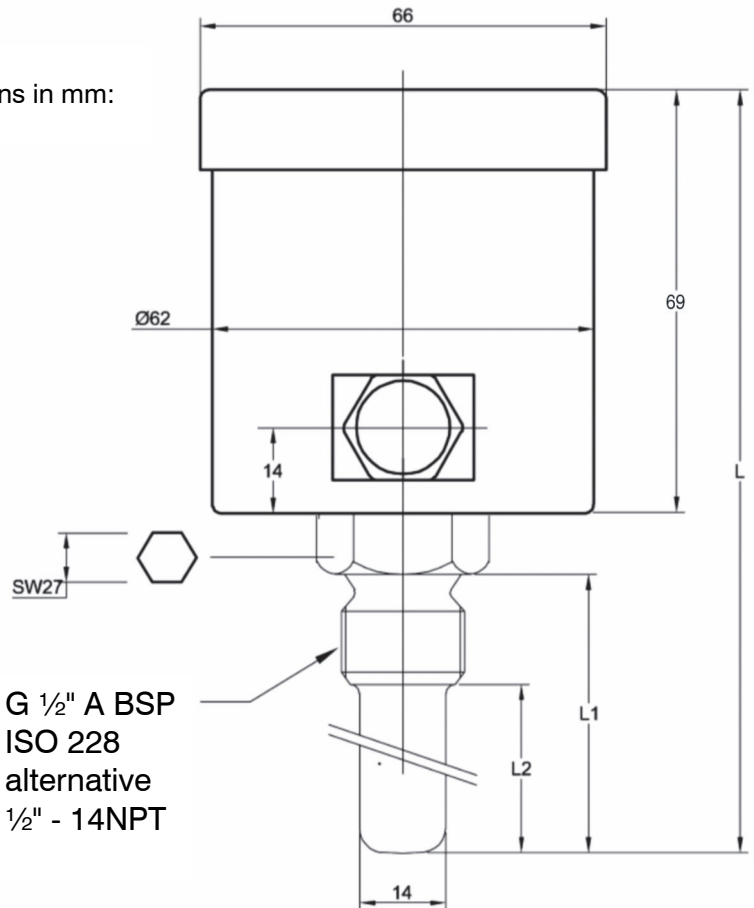
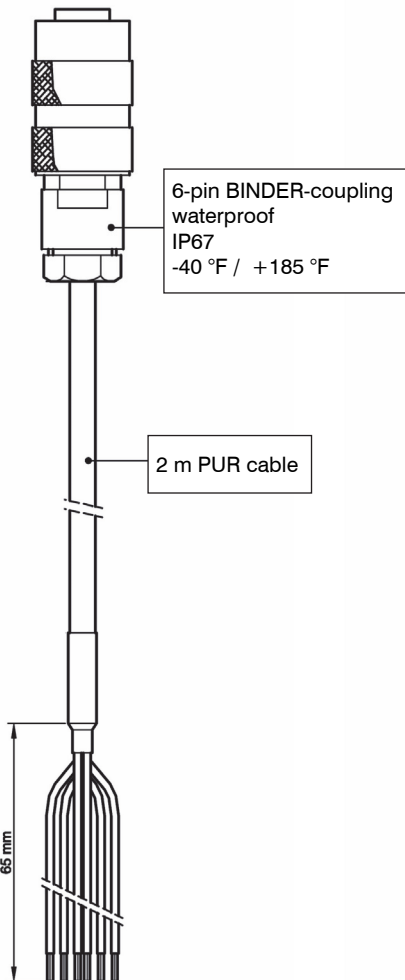

Type	L	L1	L2
Standard	119	30	12.5
S110/45	124	45	27.5
S110/67	156	67	49.5
S110/90	179	90	73.0

weber

Sensors GmbH Strohdeich 32
Sensors Ltd. 66 Eastbourne Road, Southport
Sensors LLC. 4462 Bretton Court, Building 1, Suite 7

DE-25377 Kollmar, Germany Tel.: +49 (0)4128 - 591 Fax: - 593
Merseyside PR8 4DU, UK Tel.: +44 (1704) - 551684 Fax: - 551297
Acworth, Georgia 30101, USA Tel.: +1 (770) 592 - 6630 Fax: - 592 6640

www.captor.de
info@captor.de
sales@captor.co.uk
sales@captor.com