

Flow switch for liquid media



flow-captor 413x.1x

The flow-captor 413x.1x is ideally suited for use in automation processes or other industrial applications where liquid media must be monitored. The sensor works according to the calorimetric measuring principle, fully electronic and without mechanically moving parts. The flow-captor detects the flow velocity of the medium and converts it into an electrical signal.

- precise switching flow monitor
- high switching accuracy even with slower flows
- separate setting for set-point and fixed range of 0.4 m/s, 1.0 m/s and 2.0 m/s
- display of the flow and the switching point via LED chain
- LED for output status
- robust industrial design (special encapsulation)
- ISO 9001:2015



Control and Display Panel

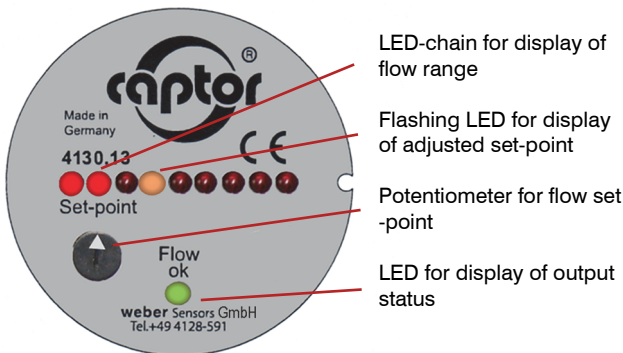

Example of operation

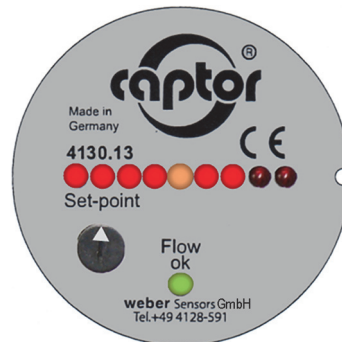

- Measuring range 100 % (9. LED)
- Set-point adjusted to 50 % of end value (5. LED)
- Flow speed equates 75 % (7. LED)
- Green LED is ON: Flow rate is above the adjusted set-point.



1/2" BSP thread standard size



1/4" BSP thread for smaller pipe diameter

Sensor heads

The sensor head is constructed of only one piece of electropolished stainless steel and without any sensor element intruding into the medium. Easy installation by means of T-piece or welded fitting.



flow-captor 413x.1x S101

Cooling version for medium temperature up to 130 °C

The flow-captor 412x.1x is available with different sensor head versions:

- 1/2" BSP thread – standard size –
- extended sensor probes with 1/2" BSP thread are available
- NPT thread as option
- 1/4" BSP thread for smaller pipes

For aggressive media other materials can be offered on request.

The housing is constructed of glass fibre reinforced PBTP (Ultradur ®). The electronics inside is completely epoxy resin encapsulated.

weber

Sensors GmbH Strohdeich 32
 Sensors Ltd. 66 Eastbourne Road, Southport
 Sensors LLC. 4462 Bretton Court, Building 1, Suite 7

DE-25377 Kollmar
 Merseyside PR8 4DU, UK
 Acworth, Georgia 30101, USA

Tel.: +49 (0)4128 - 591 · Fax: - 593
 Tel.: +44 (1704) - 551684 · Fax: - 551297
 Tel.: +1 (770) 592 - 6630 · Fax: - 592 6640

www.captor.de
 info@captor.de
 sales@captor.co.uk
 sales@captor.com

flow-captor 413x.1x

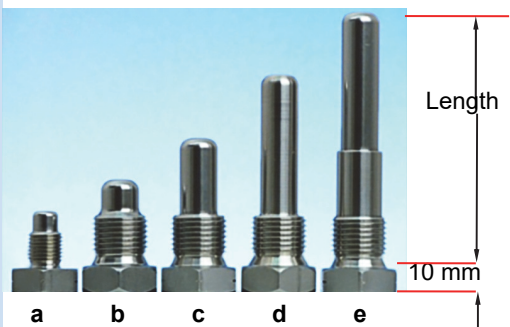
Technical data		
Type	4130.1x	4131.1x
Medium	water-based	oil-based
Sensor data		
Measuring range	0 - 0.4 m/s, 1.0 m/s or 2.0 m/s (must be specified when ordering)	
Set-point range	approx. 15 % - 90 % of range setting	approx. 15 % - 90 % of range setting
Medium temperature	-20 °C to +80 °C	
Ambient temperature	-20 °C to +70 °C	
Pressure	max. 100 bar (1450 PSI)	
Response time	2 sec. - 10 sec. depending on range setting	2 sec. - 15 sec. depending on range setting
Linearity deviation	< 5 % *1	< 5 % *2
Repeatability tolerance	< 2 %	
Hysteresis	approx. 10 %	
Temperature drift	< 0,3 % K	
Mechanical data		
Protection class	IP65	
Material: Housing	PBTP, glass fibre reinforced (Ultradur ®)	
Material: Sensor head	stainless steel AISI 303 (other material on request)	
Sensor head sizes		a) flow-captor 413x.1xA / 1/4" BSP Length 20 mm, 1/4" BSP
(A): Sensor head AISI 316		b) flow-captor 413x.1x / 1/2" BSP Length 30 mm, 1/2" BSP
(S110/xx): Length from hexagon bolt to sensor tip		c) flow-captor 413x.1xA / 1/2" BSP S110/45 Length 45 mm, 1/2" BSP
		d) flow-captor 413x.1xA / 1/2" BSP S110/67 Length 67 mm, 1/2" BSP
		e) flow-captor 413x.1xA / 1/2" BSP S110/90 Length 90 mm, 1/2" BSP
Electrical connection	integrated plug connection with PG9 fitting, 2 m oilflex cable 3 x 0,5 mm ²	
Body dimensions	see drawing	
Electrical data		
Operating voltage	18 to 30 VDC, incl. residual ripple	
Current consumption	max. 150 mA (pulsed)	
Power consumption	approx. 1 W	
Switching current	≤ 400 mA	
Circuit protection	reverse polarity, short circuit and overload	
Voltage drop	< 2.5 V at max. load	
Initial operation	approx. 10 sec. after connection of power	
Electrical output	.12	.13
Switching condition with flow < switching point	energized, switched	currentless, not switched
LED	off	off
Switching condition with flow > switching point	currentless, not switched	energized, switched
LED	green	green
Temperature data		
Type	412x.1x S101	
Medium temperature in relation to ambient temperature	Medium temperature max.	Ambient temperature max.
	130 °C	30 °C
	120 °C	40 °C
	110 °C	50 °C
	100 °C	60 °C
	90 °C	70 °C
	Medium temperature min.	Ambient temperature min.
-20 °C	-20 °C	
-30 °C	-10 °C	

*1 related to water

*2 calibrated with insulation oil type "Shell Diala S4 ZX-I"

Flow switch for liquid media



flow-captor 412x.1x

Connection diagram:

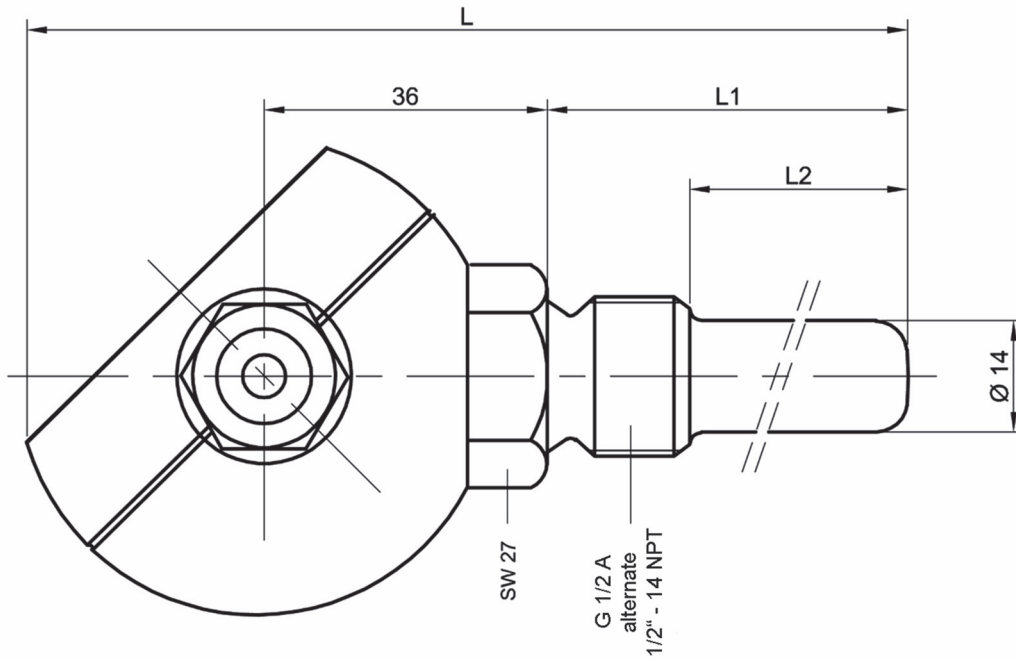
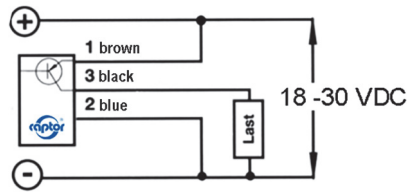

Type	L	L1	L2
Standard	95	30	12,5
S110/45	110	45	27,5
S110/67	132	67	49,5
S110/90	155	90	73,0

weber

Sensors GmbH Strohdeich 32
 Sensors Ltd. 66 Eastbourne Road, Southport
 Sensors LLC. 4462 Bretton Court, Building 1, Suite 7

DE-25377 Kollmar
 Merseyside PR8 4DU, UK
 Acworth, Georgia 30101, USA

Tel.: +49 (0)4128 - 591 · Fax: - 593
 Tel.: +44 (1704) - 551684 · Fax: - 551297
 Tel.: +1 (770) 592 - 6630 · Fax: - 592 6640

www.captor.de
 info@captor.de
 sales@captor.co.uk
 sales@captor.com

Technical data subject to alteration! Rev. AA 20.04.22