



G-SERIES TURBINES

(3-A High Temperature Sanitary Models)

(GSCPS)



To the owner...

Congratulations on receiving your FLOMEC® G-Series Sanitary Turbine. We are pleased to provide you with a product designed to give you maximum reliability and efficiency.

Our business is the design, manufacture, and marketing of liquid handling, agricultural, and recreational products. We succeed because we provide customers with innovative, reliable, safe, timely, and competitively priced products. We pride ourselves in conducting our business with integrity and professionalism.

We are proud to provide you with a quality product and the support you need to obtain years of safe, dependable service.

President
Great Plains Industries, Inc.

TABLE OF CONTENTS

General Information ----- 2

Installation ----- 4

Maintenance ----- 5

Troubleshooting ----- 12

Troubleshooting Reference Guide ----- 15

Specifications ----- 16

Service ----- 18

Warranty ----- 20

GENERAL INFORMATION

This manual will assist you in installing and maintaining your FLOMEC G-Series Sanitary Turbine. For best results, take the time to fully acquaint yourself with all information about all components of your G-Series Sanitary Turbine. If you need assistance, contact the distributor from whom you purchased your turbine.

Product Description

FLOMEC G-Series Sanitary Turbine flowmeters are volumetric flow measurement devices. The moving fluid is used to turn a rotor, which is suspended in the flow stream. The rotating speed of the rotor is proportional to the fluid velocity or flowrate. As the blades from a spinning rotor pass by a magnetic sensor, an AC voltage pulse is generated and transmitted to the readout instrument. Each pulse is equal to a given volume of liquid; therefore “x” number of pulses are equal to a gallon, litre, pound, barrel, etc.

Turbine Sizing

FLOMEC G-Series Sanitary Turbines are identified by the internal diameter of the inlet and outlet.

Model 100	1 in.	(6.7-67 GPM)
Model 100L	1 in.	(6.7-67 GPM)
Model 150	1-1/2 in.	(17.7-177 GPM)
Model 150L	1-1/2 in.	(17.7-177 GPM)
Model 200	2 in.	(33-330 GPM)
Model 200L	2 in.	(33-330 GPM)

Turbine flowmeters should be sized in accordance to the actual flowrate and not the process pipe size. For example, a process having a flowrate of 10-20 GPM in a 1-1/2 in. process line requires Model 100 OR 100L turbine flowmeter.

Another important factor to take into consideration when sizing a turbine flowmeter is instantaneous flowrate. This is extremely important when sizing a turbine flowmeter where the volume is measured per hour or per day. For example, an application where the total output is 500 barrels per day, occurring in a 5-hour period; the recommended turbine flowmeter should be sized according to the instantaneous flowrate:

$$(500 \div 5) \times 24 \text{ or } 2,400 \text{ barrels per day}$$

Thus, requiring a 1-1/2 inch turbine flowmeter.

INSTALLATION

Turbine flowmeters are affected by both upstream and downstream process configurations. Turbine flowmeters should always be installed with a minimum of 10 pipe diameters upstream and 5 pipe diameters downstream. The only exception is the placement of the pumps, valves, etc., on the upstream end. When this occurs, 20 diameters of straight pipe should be used. The direction of flow is indicated by the arrow on the turbine. All turbine flowmeters are designed to measure flow in only one direction.

Check the items below once the turbine flowmeter is installed in the process line. This will ensure a successful start-up.

1. Before installing the magnetic sensor, make sure that it is functioning properly. This can be accomplished by checking the ohm resistance. Refer to Checking Magnetic Pickup in the Troubleshooting section.
2. If a magnetic pickup enclosure is used on a sanitary turbine, discard the seal cap that is included with the unit. If no enclosure is used, install the magnetic pickup and slip the seal cap over the magnetic pickup and threads on the adapter.

NOTE: *This is not applicable for units that use a low profile adapter.*

3. Check the interconnection cable between the turbine flowmeter and readout device. Refer to Checking the Cable Assembly section.
4. Make sure that the new or correct K-factor is entered into the readout device.

NOTE: *The K-factor is printed on the turbine body. The calibration report included with the product provides several points along the flow curve.*

Initial Start-Up

Turbine flowmeters can be installed in the horizontal or vertical position. When installing a turbine flowmeter in the vertical position, it is important that the direction of flow be up through the turbine flowmeter.

A spool should be installed in place of the turbine flowmeter during initial start-up of a new process line. The process line should be purged, thus eliminating any solids contained in the line. Once this is completed, the spool can be removed and the turbine flowmeter installed.

Whenever possible, use 20 straight pipe diameters upstream and downstream of the turbine flowmeter. The length of straight pipe upstream and downstream of the turbine flowmeter can be reduced with the use of flow straighteners or straightening vanes. A minimum of 10 straight pipe diameters upstream and 5 downstream are required.

NOTE: *Control valves should always be installed downstream of the turbine flowmeter.*

The turbine flowmeter should be installed in a location where the process line will remain full of liquid at all times. Otherwise, when the process line becomes empty and a valve is opened, the high velocity fluid hitting the turbine flowmeter rotor can cause severe damage.

When there is entrained air in the process line, an air eliminator should be used. This entrained air causes air pockets and these air pockets will cause the rotor to spin at a faster rate than liquid, thus resulting in incorrect readings, which results in an overstatement of actual flowrate and volume. This condition can damage the flowmeter.

In process lines where particulates are present, a filter/strainer should be used. Refer to the table below for the recommended mesh size.

Turbine Flowmeter Size	Mesh Size
1 inch	40
1-1/2 inch	18
2 inch	14

⚠ WARNING
If liquid being measured by sleeved bearing turbine flowmeters contains large solids, install a filter or strainer.
Without the use of a filter or strainer, damage can occur to the internal components.

MAINTENANCE

Cleaning Procedures

G-Series Sanitary Turbines are designed to be compatible with commercially accepted methods of both CIP (Cleaned-In-Place) mechanical cleaning as well as intermittent SIP (Steam-In-Place) cleaning methods.

If CIP or SIP cleaning methods are not available, manual COP (Cleaning-Out-of-Place) methods can be used.

Care must be taken during system start-up, chemical cleaning, air purge or steam-cleaning processes to ensure that the turbine rotor does not over speed as damage can result to the rotor and/or bearing. Maximum allowable over range for G-Series Sanitary Turbines is 125% of maximum rated flowrate for intermittent periods.

A minimum fluid velocity of 5 foot per second (1.5 meter per second) must be maintained during the CIP process to ensure adequate cleaning.

Reference: 3-A Accepted Practices for Permanently Installed Product and Solution Pipelines and Cleaning Systems Used in Milk and Milk Product Processing Plants, Number 605-XX as amended for procedures and recommended flowrates.

The following flowrates are recommended by the 3-A Recommended Practices 605-XX to achieve 5 FPS or 1.5 MPS in the respective Sanitary Tube size:

O.D.	I.D.	FLOWRATE
1.0 in. 2.5 cm	.875 in. 2.22 cm	9.4 GPM 35.6 LPM
1.5 in. 3.8 cm	1.375 in. 3.50 cm	24 GPM 90.8 LPM
2.0 in. 5.1 cm	1.875 in. 4.75 cm	43 GPM 163 LPM

Temperature limit for SIP cleaning is primarily limited by the temperature rating on the magnetic pickup. If the pickup temperature rating will be exceeded during SIP cleaning, remove it during the cleaning process or a higher temperature rated pickup should be specified. Internal components of the G-Series Sanitary Turbine must be limited to less than 285° F (140° C). The temperature and pressure rating of gaskets and clamps used in the installation must also be taken into consideration when determining cleaning parameters.

Minimum requirements for effective sterilization with SIP cleaning are to maintain 250° F (121° C) at the coldest point in the system for a minimum of 30 minutes. This requires a minimum of 15.3 psig (106 kPa) saturated steam pressure. Normal recommended maximums for SIP cleaning on G-Series meters is 285° F (140° C) and 39 psig (269 kPa) saturated steam pressure.

Disassembling the Turbine

1. Disconnect the turbine flowmeter cable from the magnetic pickup. (Refer to Figure 1.)
2. Remove the magnetic pickup.
3. Ensure that the process line is depressurized and empty prior to removal of the turbine flowmeter. Remove the turbine flowmeter from the process line.
4. Using a small screwdriver or similar tool, insert it into the radius notch of the retaining ring on the outlet end, pull away from the groove and up, removing the retaining ring from outlet end of the turbine flowmeter. This will allow the rear support assembly and rotor to slide out of the turbine flowmeter body.
5. Remove the rear support assembly and rotor assembly before proceeding to remove the front support.

NOTE: *To remove the front support at the inlet end of the turbine flowmeter, repeat the previous retaining ring and support removal operation.*

6. Once the turbine flowmeter is taken apart, inspect the turbine flowmeter body for signs of wear or defects. The body bore should be smooth and show no evidence of wear.

NOTE: *Do not install a new replacement kit into a turbine flowmeter body that shows significant signs of wear.*

7. Examine the rotor assembly for broken and/or bent blades. Remove any foreign matter.
8. Examine the supports for signs of deterioration, such as wear marks and/or burrs along the outer edge of the support vanes.
9. When the rotor assembly or the supports show any sign of deterioration, a new replacement kit should be installed. Do not install a new replacement kit into a defective turbine flowmeter body.

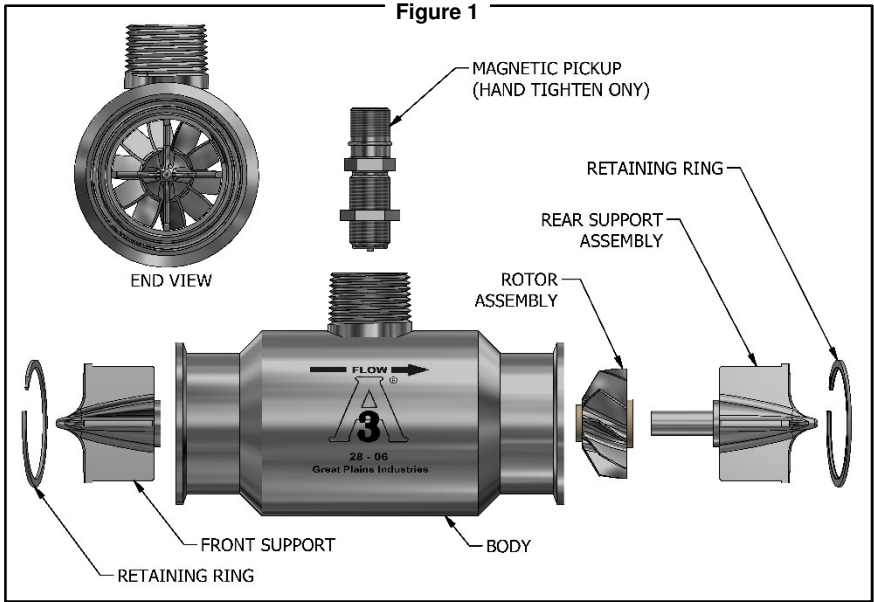

Replacement Kits

A replacement kit is comprised of all the internal component parts within the turbine flowmeter. A replacement kit consists of the following:

Parts Description	Quantity
Rotor Assembly	1
Support (Front)	1
Support Assembly (Rear)	1
Retaining Ring	2

FLOMEC Sanitary Turbine supports are not identical in design. The rear support assembly has a shaft that supports the rotor; the front support does not.

Notice that the direction of flow is displayed on the body of the turbine flowmeter. This is important when installing the supports and rotor and it also denotes the direction in which the turbine flowmeter was calibrated.

1. Install the front support placing a vane between the notches in the turbine flowmeter body. Install a retaining ring to keep the support in place.
2. Place the rotor assembly on the shaft of the uninstalled rear support assembly.

NOTE: FLOMEC Sanitary Turbine rotors are tapered on one end. The tapered end should be installed facing the front support (see Figure 1).

3. Hold the turbine flowmeter body with the rear (outlet) end down, and slide the rotor assembly and rear support assembly into the turbine flowmeter body. Make sure the vane is placed between the notches.
4. Once the rear support assembly is in place, install the retaining ring.
5. Blow into the turbine flowmeter to ensure the rotor spins freely.

NOTE: *Installation of the replacement kit is complete and the turbine flowmeter can be reinstalled into the process line.*

6. Install the magnetic pickup. **HAND TIGHTEN ONLY.**

NOTE: *Be sure to use the proper magnetic pickup, cable and connector for the application.*

7. Enter the new K-factor supplied with the replacement kit into the electronic readout device. (Refer to the calibration report.)

NOTE: *All internal replacement kits are factory calibrated and are supplied with a five point calibration certificate.*

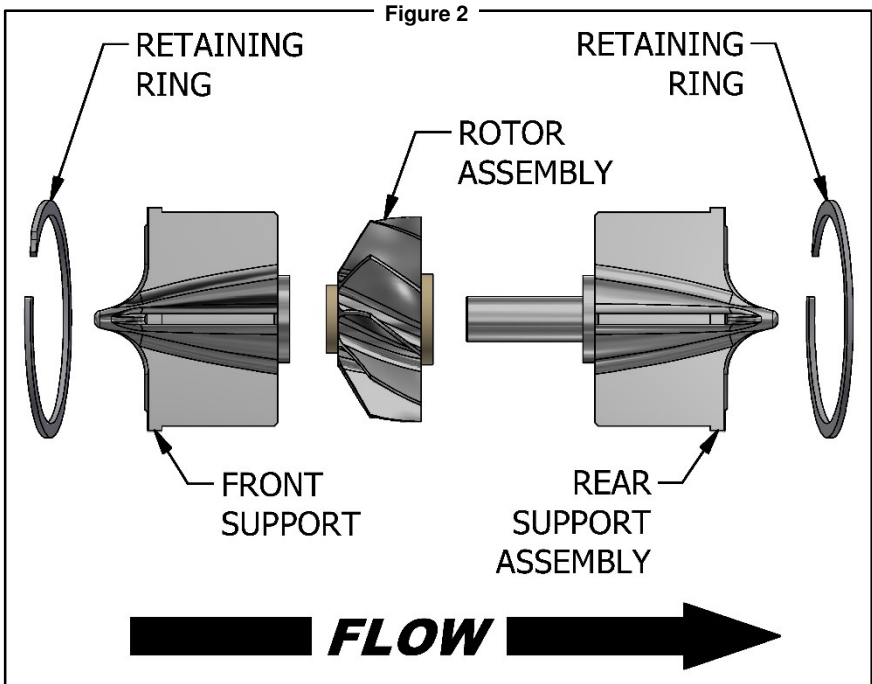

Single Post Design Replacement Kit for FLOMEC G-Series Sanitary Turbines

Replacement Kits for Sanitary Turbine Flowmeters (GSCPS)

Size	Flow Range (Gallons Per Minute)	Model	Part No.
1 in.	6.7 - 67 GPM	GSCPS-100 GSCPS-100L	81008074
1-1/2 in.	17.7 - 177 GPM	GSCPS-150 GSCPS-150L	81508074
2 in.	33 - 330 GPM	GSCPS-200 GSCPS-200L	82008074

Magnetic Pickups

FLOMEC offers two types of magnetic pickups: Standard and Wire Lead. (See Figure 3.)

When choosing a magnetic pickup, the turbine meter and electronics are generally already known. Electronics can be either Local or Remote. Remote electronics include FLOMEC Remote Displays or output to customer-supplied equipment. Follow the next three steps when choosing a magnetic pickup.

Figure 3

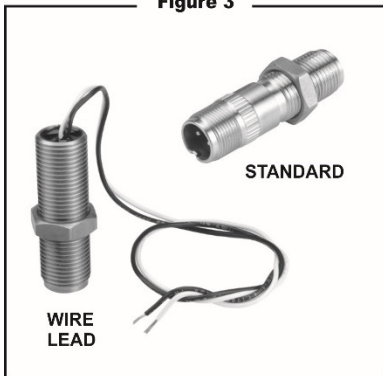

1. Select your size: 1 in., 1-1/2 in., or 2 in.
2. Choose Local or Remote/Output.
 - Local uses a wire lead pickup.
 - Remote/Output requires a connector.
3. Choose either Sine Wave or Square Wave as your signal type.
 - Sine Wave does not require external power for the sensor, and can be used with battery powered displays.
 - Square Wave requires external power to power the sensor.

Selection Guide for 1 in. 1-1/2 in., 2 in. Turbine Meters

Magnetic Pickup Type	Part No.	Application	Cable Type
Wire Lead Standard	81003000	Meter mount electronics. Temperature range: -100°F to +250°F. Sine wave output.	None
Standard	81001000	Remote mount electronics. Temperature range: -100°F to +250°F. Sine wave output.	S
Herm/High Temp.	81002000	Remote mount electronics. Temperature range: -450°F to +258°F. Sine wave output.	H or T
High Temp. Standard	81007000	Remote mount electronics. Temperature range: -450°F to +800°F. Sine wave output.	H or T
Active Digital	81004000	Remote mount electronics. Temperature range: -40°F to +248°F. Square wave, open collector output, 5-32 VDC required. Signal output: 0-10V, NPN.	D

Magnetic Pickup Enclosures

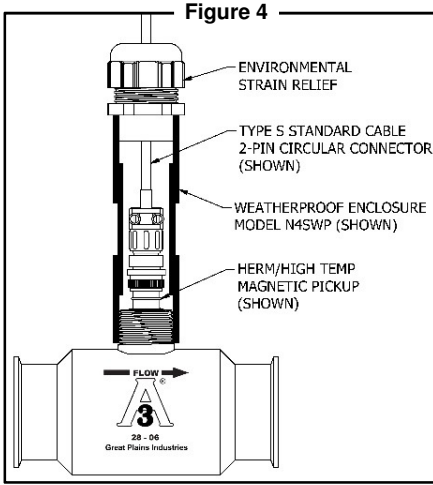

Pickup Enclosures are optional on G-Series Sanitary Turbine Meters. Choose from two versions of weatherproof pickup enclosures (see Figure 4):

- Model N4AWP - Part No. 80001101, Zinc Plated Steel
- Model N4SWP - Part No. 80001105, 316 Stainless Steel

Cable Assemblies (Connector Included)

Figure 5

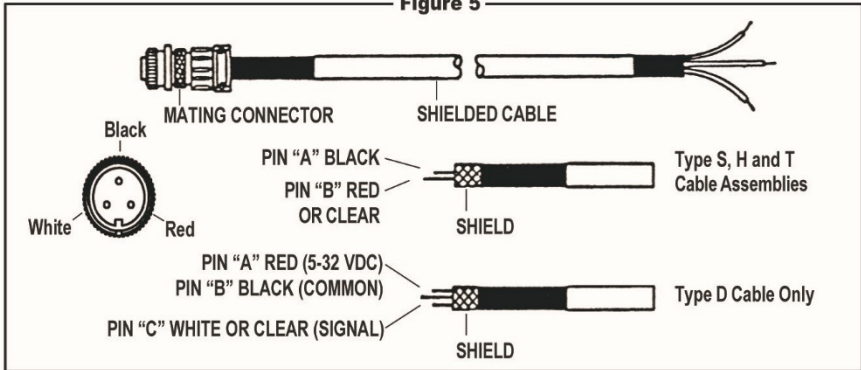

Cable Length Selection Guide

Cable Length	Type "S" Standard (2 Conductor)	Type "D" Digital or RF (3 Conductor)	Type "H" Water Resistant (2 Conductor)	Type "T" Hi-Temperature (2 Conductor)
8 inch	83001001	83002001	83003001	83004001
5 feet	83001005	83002005	83003005	83004005
10 feet	83001010	83002010	83003010	83004010
15 feet	83001015	83002015	83003015	83004015
20 feet	83001020	83002020	83003020	83004020
25 feet	83001025	83002025	83003025	83004025
30 feet	83001030	83002030	83003030	83004030
40 feet	83001040	83002040	83003040	83004040
50 feet	83001050	83002050	83003050	83004050
75 feet	83001075	83002075	83003075	83004075
100 feet	83001100			
125 feet	83001125			

LOW RANGES					
Size	Gallons Per Minute		Litres Per Minute		Frequency Output
	Min.	Max.	Min.	Max.	
1 in.	6.7	67	25.2	252	100 - 1000 Hz
1-1/2 in.	17.7	177	67.0	670	100 - 1000 Hz
2 in.	33	330	124.9	1249	100 - 1000 Hz

DIMENSIONS		
Size	Height	Length
1 in.	2.75	3.562
1-1/2 in.	3.00	4.594
2 in.	3.25	6.063

Dimensions are provided in inches.

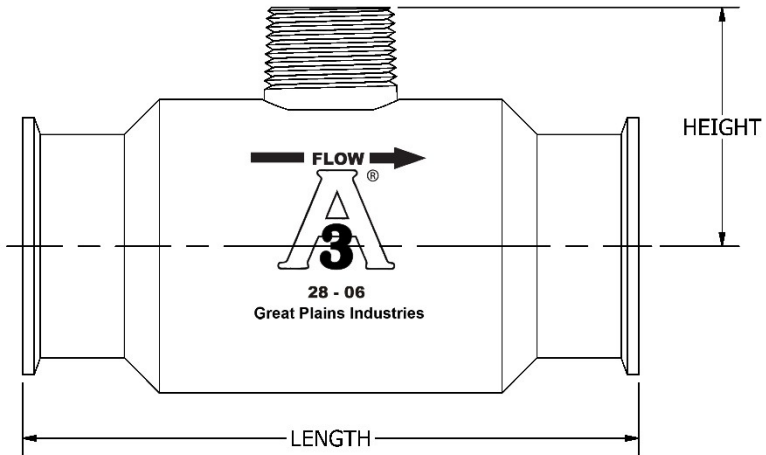

(For optional low profile models, subtract 1 inch from height.)

TROUBLESHOOTING

Locating the Problem

To determine the location of the problem, whether it is occurring at the turbine flowmeter or at the electronic readout device, disconnect the cable assembly from the magnetic pickup and connect the cable from the portable rate indicator onto the magnetic pickup. (Refer to Figure 6.)

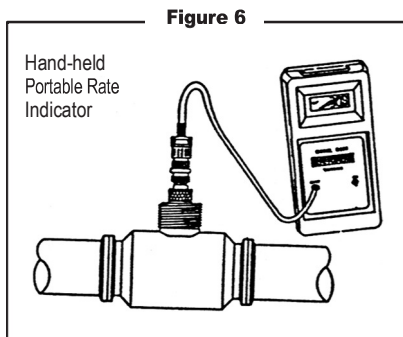

The portable rate indicator will display the instantaneous rate of flow through the turbine flowmeter. If the rate displayed is equal to the rate of the process, then both the magnetic pickup and the turbine flowmeter are operational. The problem will be located in either the cable assembly or the electronic readout device

When there is no rate displayed on the portable rate indicator, the problem may be caused by a defective magnetic pickup or turbine flowmeter.

Checking the Magnetic Pickup

To determine the status of a hermetically sealed, two-wire lead, or standard magnetic pickup, simply remove it from the turbine flowmeter, and using an ohm meter, measure the ohm resistance by placing the leads of the ohm meter on each pin of the magnetic pickup. (Refer to Figure 7.)

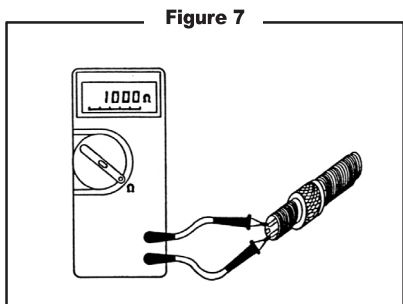

If the ohmmeter reads 1400 ohms $\pm 20\%$, then the magnetic pickup is good and should **NOT** be replaced. If the ohmmeter reads less than 1000 ohms, install a new magnetic pickup. **DO NOT** throw the old magnetic pickup away. Failure of the magnetic pickup may have been caused by moisture trapped inside. In some cases when the magnetic pickup is allowed to dry, it has become completely functional and can be reused. When the ohmmeter reads in excess of 1700 ohms, the magnetic pickup is defective and should be discarded.

NOTE: It is recommended that the ohm resistance be measured before installing a used magnetic pickup.

Checking the Turbine Flowmeter

Once it has been determined that the magnetic pickup is functional and there is no output displayed on the portable rate indicator, it can be concluded that the problem lies within the turbine flowmeter. Remove the turbine flowmeter from the process line. **DO NOT** remove the internals at this time.

Visually inspect the internals of the turbine flowmeter. Check for particulates and/or foreign objects, which may have lodged between the rotor and the body. In the event an object is detected, simply remove the retaining ring on the outlet side of the turbine flowmeter and remove the support and rotor assembly. Once the turbine flowmeter parts are free from any foreign matter, reassemble.

NOTE: *Always ensure that a support vane is installed between the indentation marks on the body.*

Upon completion, verify the rotor spins freely, reinstall the turbine flowmeter into the process line.

If there are no signs of particulates or any other foreign matter obstructing the rotor, try blowing into the turbine flowmeter. If the rotor does not spin freely, insert a thin screwdriver or similar tool, gently so as not to damage any of the rotor blades, and turn the rotor.

There may be another cause for the rotor to drag or stop, such as incorrect bearing material used for the application. For example, non-compatibility of the bearing material with the process liquid, bearing material may not withstand the temperature of the application, etc. When there is uncertainty with respect to the selection of bearing material for a given application, contact GPI.

Before installing a new replacement kit, inspect the turbine flowmeter body for wear and damage. By placing your finger inside the turbine flowmeter body, feel for any signs of wear such as grooves, ridges, irregular spots. If such signs are evident, it is a strong possibility that the turbine flowmeter body is damaged and the installation of a new replacement kit is **NOT** recommended.

When a new replacement kit is installed inside a damaged turbine flowmeter body, the internals will be ruined after a short period of operation and will have to be discarded. In the event it is uncertain whether the turbine flowmeter body is functional, it should be sent to GPI so the I.D. dimension of the turbine flowmeter body bore can be checked. If it is found to be within tolerance, a new set of internals will be installed. This will eliminate the possibility of using and/or discarding a turbine flowmeter that shows signs of wear.

NOTE: *A good turbine flowmeter body should have a smooth inner bore free of wear signs.*

If it is determined that the turbine flowmeter body is in good condition, install a new replacement kit and reinstall the turbine flowmeter into the process line.

Checking the Cable Assembly

This can be accomplished with the aid of a frequency oscillator. Simply plug the cable assembly with the mating connector end that is located at the turbine flowmeter into the frequency oscillator. The frequency oscillator will simulate the output of a turbine flowmeter. If an output is displayed on the electronic readout device, then the cable assembly is good.

In the event an output is not displayed, disconnect the frequency oscillator from the cable assembly and connect the cable supplied with the frequency oscillator directly to the electronic readout device, the same as you would a turbine flowmeter cable assembly. (Refer to Figure 8.)

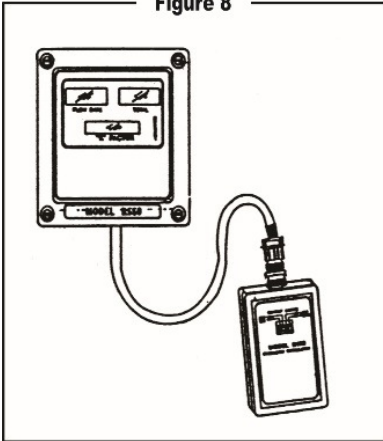
Figure 8

When the frequency oscillator is connected and an output is displayed on the electronic readout device, this indicates that the turbine flowmeter cable assembly is defective and should be replaced. If no output is displayed, the turbine flowmeter cable assembly is good and the problem lies within the electronic readout device.

Checking the Electronics

Using the frequency oscillator and the cable that is supplied, connect it to the electronic readout device, the same as you would a turbine flowmeter cable assembly. Once the frequency oscillator is connected, if no output is displayed on the electronic readout device, check to ensure that the power is on, the fuses are good, and the correct K-factor is dialed/programmed into the electronic readout device. After verification of these items, if there is still no output displayed and/or registered, then the manufacturer of the electronic readout device should be consulted.

Troubleshooting Reference Guide		
Symptom	Probable Cause	Solution
No output is displayed or registered	Defective magnetic pickup	Refer to the Checking the Magnetic Pickup section.
	Foreign matter obstructing the turbine flowmeter rotor	Refer to the Checking the Turbine Flowmeter section.
	Defective turbine flowmeter internals	Refer to the Checking the Turbine Flowmeter section.
	Defective turbine flowmeter cable assembly	Refer to the Checking the Cable Assembly section.
	Defective electronic/readout device	Refer to the Checking the Electronics section.
More volume/output than displayed or registered.	Rotor may drag due to foreign matter obstruction	Refer to the Checking the Turbine Flowmeter section.
	Magnetic pickup not screwed down all the way into the turbine flowmeter body, causing it not to detect all the rotor blades as they pass.	Screw the magnetic pickup all the way down into the turbine flowmeter body. Hand-tighten only.
	Turbine flowmeter installed backwards.	Install the turbine flowmeter in accordance with the process flow direction.
	Turbine flowmeter rotor installed backwards.	Install the turbine flowmeter rotor in accordance with the process flow direction.
	K-factor is too high in electronic/readout device.	Verify K-factor used. K-factor should be decreased.
Less volume/output than displayed or registered.	Caused by entrained air in the process line.	Install an air eliminator upstream of turbine flowmeter.
	K-factor is too low in electronic/readout device.	Verify K-factor used. K-factor should be increased.

SPECIFICATIONS

Accuracy *	±0.5% of the true flow at any point within the linear range of the turbine flowmeter.
Linearity *	±0.5% of the mean K- factor throughout the linear range.
Repeatability *	±0.1% of the indicated flow throughout the linear range.
Response Time: 1 in., 1-1/2 in. & 2 in	2-5 milliseconds for step change in flowrate.
Frequency Output: 1 in., 1-1/2 in. & 2 in.	100 - 1000 Hz (Over the linear range)
Voltage Output: 1 in., 1-1/2 in., & 2 in	Approx. 100 mV @ 100 Hz to 1.0 Volt (r.m.s.) @ 1000 Hz
Maximum Overage	Up to 125% of maximum flowrate for intermittent periods.
Operating Temperature	-100° F to +225° F (-70° C to +107° C)
Standard Materials of Construction	
Housing	316 Stainless Steel
Rotor	Nickel Plated CD4MCu Stainless Steel
Shaft	316 Stainless Steel
Rotor Supports	316 Stainless Steel
Sleeve/Thrust Bearing	PEEK
Retaining Rings	300 Series Stainless Steel

* Data based on water calibration @ 77°F (25°C).

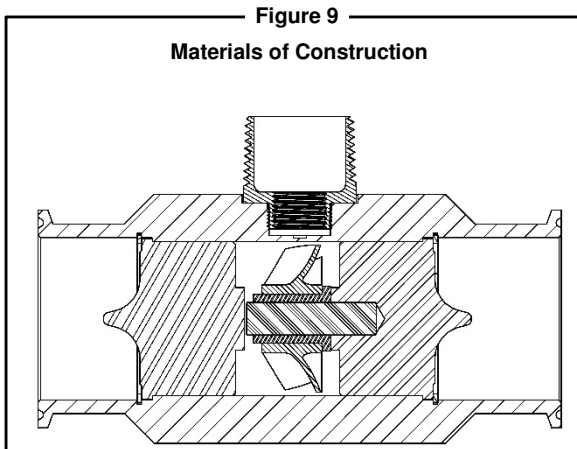

FLOW RELATED FORMULAS

GPM = $\frac{Hz \times 60}{K-factor}$

Hz = $\frac{GPM \times K-factor}{60}$

K-factor = $\frac{Hz \times 60}{GPM}$

Pulses Per Litre = $\frac{K-factor}{3.785}$

Pulses Per Barrel = K-factor x 42

Pulses Per Cubic Meter = $\frac{K-factor}{.003785}$

Pulses Per Pound = $\frac{K-factor}{Pounds Per Gallon}$

GPM = $\frac{Pounds Per Hour}{500 \times S.G.}$

Pounds Per Hour = 500 x S.G. x GPM

Pounds Per Gallon = S.G. x 8.33 (Water)

BPH = GPM x 1.42857

BPD = GPM x 34.286

BPM = GPM x 0.238

GPS = GPM x .01666

GPD = GPM x 1440.0

GPM = BPD x .029167

GPM = BPH x 0.7

CFM = GPM x .13368

BPH = Barrels Per Hour
 BPD = Barrels Per Day
 BPM = Barrels Per Minute
 CFM = Cubic Feet Per Minute

GPS = Gallons Per Second
 GPD = Gallons Per Day
 GPM = Gallons Per Minute

PRESSURE DROP vs FLOWRATE

Pressure Drop vs. Flowrate

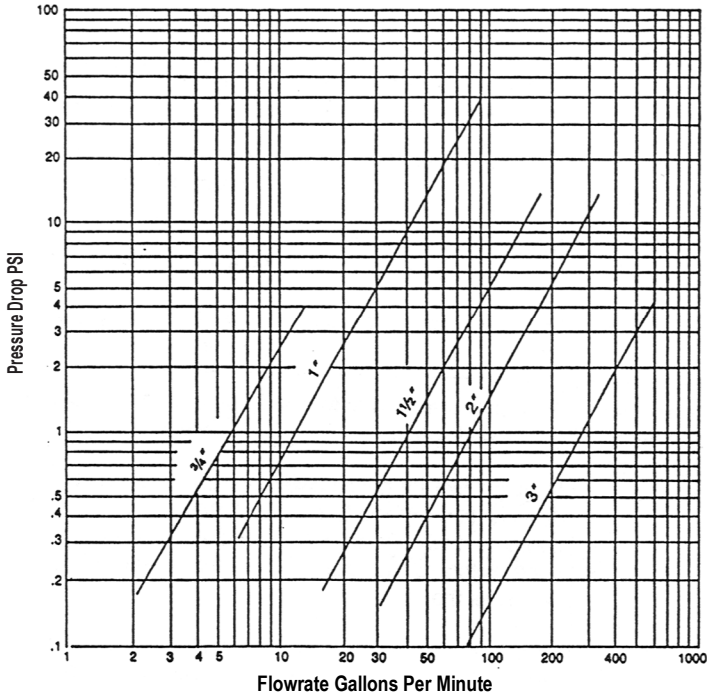

For estimating pressure drops on liquids other than water, use the following formulas:

$$P = [VISC (CPS)]^{1/4} \times [S.G.]^{3/4} [PH O]$$

Where: CPS = Absolute Viscosity in Centipoise
 SG = Specific Gravity
 PH O = Pressure Drop at the Operating Flowrate from the Chart

SERVICE

For warranty consideration, contact your local distributor. If you need further assistance, contact the GPI Customer Service Department at:

1-888-996-3837

You will need to:

- Provide the model number of your turbine.
- The serial number of your turbine.
- Specific information about part numbers and descriptions.

For warranty work always be prepared with your original sales slip or other evidence of purchase date.

RETURNING PARTS

Please contact the factory before returning any parts. It may be possible to diagnose the trouble and identify needed parts in a telephone call. GPI can also inform you of any special handling requirements you will need to follow covering the transportation and handling of equipment that has been used to transfer hazardous or flammable liquids.

CAUTION: *Do not return turbines without specific authority from the GPI Customer Service Department. Due to strict regulations governing transportation, handling, and disposal of hazardous or flammable liquids, GPI will not accept turbines for rework unless they are completely free of liquid residue.*

CAUTION: *Turbines not flushed before shipment can be refused and returned to the sender.*



FLOMEC® TWO-YEAR LIMITED WARRANTY

Great Plains Industries, Inc. 5252 E. 36th Street North, Wichita, KS USA 67220-3205, hereby provides a limited warranty against defects in material and workmanship on all products manufactured by Great Plains Industries, Inc. This product includes a 2-year warranty. Manufacturer’s sole obligation under the foregoing warranties will be limited to either, at Manufacturer’s option, replacing or repairing defective Goods (subject to limitations hereinafter provided) or refunding the purchase price for such Goods theretofore paid by the Buyer, and Buyer’s exclusive remedy for breach of any such warranties will be enforcement of such obligations of Manufacturer. The warranty shall extend to the purchaser of this product and to any person to whom such product is transferred during the warranty period.

The warranty period shall begin on the date of manufacture or on the date of purchase with an original sales receipt. This warranty shall not apply if:

- A. the product has been altered or modified outside the warrantor’s duly appointed representative;
- B. the product has been subjected to neglect, misuse, abuse or damage or has been installed or operated other than in accordance with the manufacturer’s operating instructions.

To make a claim against this warranty, or for technical assistance or repair, contact your FLOMEC distributor or contact FLOMEC at one of the locations below.

In North or South America contact

Great Plains Industries, Inc.
5252 East 36th St. North
Wichita, KS 67220-3205
USA

888-996-3837

www.flomecmeters.com
(North America)

Outside North or South America contact

GPI Australia
(Trimec Industries Pty. Ltd.)
12/7-11 Parraweena Road
Caringbah NSW 2229
Australia

+61 02 9540 4433

www.flomec.com.au

The company will step you through a product troubleshooting process to determine appropriate corrective actions.

GREAT PLAINS INDUSTRIES, INC., EXCLUDES LIABILITY UNDER THIS WARRANTY FOR DIRECT, INDIRECT, INCIDENTAL AND CONSEQUENTIAL DAMAGES INCURRED IN THE USE OR LOSS OF USE OF THE PRODUCT WARRANTED HEREUNDER.

The company herewith expressly disclaims any warranty of merchantability or fitness for any particular purpose other than for which it was designed.

This warranty gives you specific rights and you may also have other rights which vary from U.S. state to U.S. state.

NOTE: In compliance with MAGNUSON MOSS CONSUMER WARRANTY ACT – Part 702 (governs the resale availability of the warranty terms).

Wichita / Sydney



© 2021 Great Plains Industries, Inc., All Rights Reserved.
Great Plains Industries, Inc. / 888-996-3837 / flomecmeters.com