



SYSTEM DESIGN COMPONENT SELECTION SYSTEM LAYOUT

DESIGN GUIDE  
**BATCH CONTROLLING**



# Table of Contents

<b>Introduction</b> .....	<b>4</b>
Batch Controlling .....	4
Benefits of a Batch Controller .....	4
<b>Piping System Design</b> .....	<b>5</b>
Single Stage (single valve) System .....	5
Dual Stage (two valve) System .....	5
System Components .....	6
Piping Layout .....	6
<b>Component Selection</b> .....	<b>7</b>
Selecting a Batch controller .....	7
Selecting a Flowmeter .....	9
Selecting Valves .....	10
Selecting Relays .....	11
<b>Designing a Pneumatic Control System</b> .....	<b>12</b>
<b>Electrical System Layout</b> .....	<b>13</b>
<b>Glossary</b> .....	<b>21</b>

# Introduction

## Batch Controlling

A batch controller is a piece of electronic equipment that, when installed with an appropriate flowmeter, measures the volume of liquid that flows through a line and controls a valve to dispense an exact quantity of liquid into a process.

Batch controllers are used in manufacturing businesses of all sizes to improve the quality of their product, eliminate wastage of ingredients, and reduce the labour cost in their production.

Batch controllers are particularly valuable for businesses operating repetitive processes, such as:

- Commercial baking or food manufacturing operations
- Commercial breweries
- Cosmetics and pharmaceutical manufacturers
- Chemical manufacturers diluting concentrates or powdered chemicals to be sold as a diluted liquid.
- Commercial cleaners breaking down bulk chemical into bottles for use by employees.
- Packaging finished product into bottles, drums or intermediate bulk containers

## Benefits of a batch controller

Batch controllers have a range of benefits including;

- Automating repetitive liquid dispensing tasks without increasing labour cost.
- Improved utilization of existing workforce by turning liquid dispensing tasks into a 'button press', allowing workers to move on to other tasks while the batch controller does its job.
- The ability to scale up a manufacturing plant without adding a large workforce.
- Improved quality of the manufactured product by more accurately controlling the volume of ingredients.
- Avoiding spoiled batches which could be caused by accidental over addition of an ingredient.
- Reduced wastage of ingredients or concentrates.
- Improved occupational work health and safety by avoiding spillage of hazardous liquids.

# Piping System Design

## Single Stage (single valve) System

Single stage systems utilise a single valve for on/off control of the liquid. Single stage systems are the simplest way to implement a batch controller into your process, however they do have limitations.

In cases with high flow-rates a single stage system can be less accurate than a dual stage (two valve) system, although by far the biggest down-side of single stage systems is pressure spikes – commonly referred to as water hammer. Pressure spikes can occur when the liquid has a high amount of momentum; from a large pipe size, high flowrates, or both. In these systems a quickly closing valve causes the liquid to stop suddenly, creating a rapid spike in pressure and potentially damaging valves, fittings, or pumps.

A single stage system is the recommended solution for 25mm/1" lines and smaller, with pressures below 10Bar / 150psi. Larger gravity fed systems (no pump), or large pipes with very low flowrates can also work effectively as a single stage system. As a last resort, pressure spikes can be eliminated using a water-hammer arrestor or pressure accumulator.

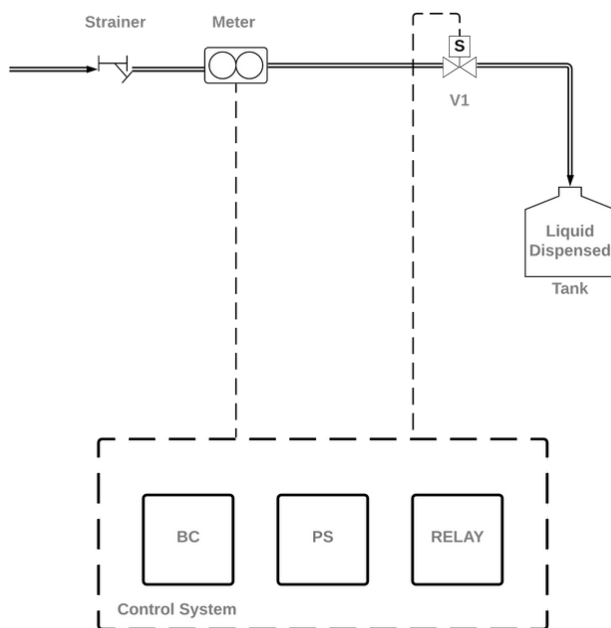

## Dual Stage (two valve) System

Dual stage systems utilise two valves for on/off control of the liquid; with one valve controlling the bulk of the liquid flow, and second valve providing fine control of the liquid volume right at the end of the batch. The dual stage system also allows the batch controller to stop the liquid flow gradually, preventing pressure spikes which could damage equipment.

Dual stage (two valve) systems are recommended for systems in pipe sizes larger than 25mm / 1", except in low pressure systems, such as gravity flow from a head tank. Another case where a single stage system may be used in pipes larger than 25mm / 1" is systems with oversized piping such as for high viscosity liquids.

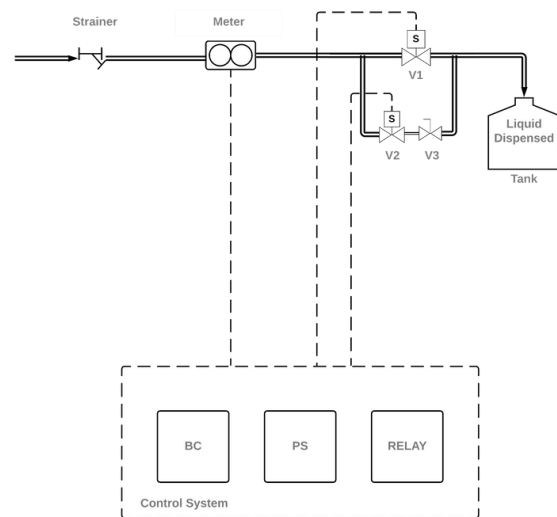



## System Components

(Refer to diagrams on previous page)

**M** – Flow meter

**V1** – High flow valve

**V2** – Low flow valve

**V3** – Low flow throttling valve – optional; to control the flowrate of the low-flow circuit to optimise batch accuracy or minimise pressure spikes

**ST** – Strainer – Optional; recommended for positive displacement flowmeters (e.g. oval gear meters)

**BC** – Batch controller - EB11, or F130.

**PS** – Power supply

**Relay** – Required for systems using high power DC solenoid valves, or AC mains powered solenoid valves

☞ Ideally the solenoid valve should be located as close as possible to the outlet of your piping system. This will limit the amount of liquid that has to drain out of your pipe at the end of the batch. If there is a long length of pipe between the solenoid valve and the outlet, this must slowly drain at the end of every batch which can reduce the productivity of your automated system. If a new batch is started before the pipe has completely drained then it will affect the accuracy of your next batch volume.

☞ If the solenoid valve cannot be located close to the outlet of your system, an alternative is to create a 'transfer point' at the outlet of your piping. Do this by installing an 'S bend' at the end of your piping. Designing your piping in this way means that the majority of your piping will remain full at the end of a batch.

## Piping Layout

When designing the piping layout for a batch control system it is important to keep the flowmeter full of liquid at all times and avoid any chance of air entrapment within the meter or valve.

To achieve this the following points should be followed, which will produce optimal batch accuracy, and will avoid any reliability issues.

- ☞ The flowmeter should be installed upstream of the solenoid valve(s)
- ☞ For vertical installations the liquid should travel from bottom to top, i.e. it should rise vertically through the flowmeter.
- ☞ To avoid draining of the flowmeter it is best to use a pump with flooded suction, or install a foot valve

# Component Selection

## Selecting A Batch Controller

FLOMEC® offers four different batch controllers to suit different user needs.



### EB11 'EasyBatch' Batch Controller

Recommended for most applications using single-stage or dual-stage control of any non-flammable liquids, and in environments where no flammable vapours or gases are present.



### F130 Intrinsically Safe Batch Controller

Recommended for all application using single-stage or dual-stage control with flammable liquids, or environments where flammable vapours or gases are present.



### D030 DIN Panel Mount Batch Controller

Use for single-stage applications where mounting in a DIN standard instrumentation panel is required.



### N410

For users who want a single piece of equipment with no external relays or power supplies the N410 batch controller offers everything in one package. The N410 offers dual-stage control with integrated heavy duty mechanical relays, full numerical keypad for quicker entry of batch volumes, and is directly powered from AC mains voltage.

## Batch Controlling in a Hazardous Area

A hazardous area is one where the atmosphere contains flammable gases or vapours which may ignite in case of a spark or a hot surface. Hazardous areas usually occur where a business is handling flammable liquids, or gases. A hazardous area may also be caused by combustible dusts or fibres.

Hazardous areas require the utmost care in selecting and installing the right certified equipment to ensure explosion safety. All installation must be carried out by personnel competent in explosion protected electrical systems, and in most regions must be inspected by a specialised electrical inspector prior to use.

If there is no possibility of flammable gases/vapours occurring then you are in a 'safe area' and an EB11 batch controller is suitable.

FLOMEC recommends the F130 intrinsically safe batch controller in combination with an OM series meter fitted with a reed switch 'simple apparatus', for all applications in hazardous areas where the IECEx or ATEX schemes are accepted.



Even if you are handling flammable liquids and the atmosphere in your factory does not **normally** contain flammable vapours or gases, it would still be considered a hazardous area due to the risk of flammable gases/vapours occurring from a leak.



For applications in North America where FM approval is required FLOMEC will only be able to supply batch controllers for safe areas.



## Selecting a Flowmeter

FLOMEC® offers flowmeters from a wide range of technologies and a wide range of materials, so we can offer a batch controlling solution for almost all liquid applications.

Where the liquid properties and the budget allows it, it is preferable to use positive displacement flowmeters in batch controlling applications. This is because positive displacement (PD) meters offer an instantaneous response to valve opening/closing, which assists batch accuracy. PD meters also have a very wide operating flow-rate range which provides optimal batch accuracy in dual stage applications where the low-flow second stage can affect accuracy in other metering technologies.

Selecting a flowmeter can be a complex task; some basic product recommendations are shown below, however detailed meter selection will not be described in this guide. With FLOMEC's wide range of flowmeter products and skilled technical team we can solve almost all measurement applications, so if the basic suggestions below do not meet your exact requirements please go to [www.flomec.com.au](http://www.flomec.com.au) or [www.flomecmeters.com](http://www.flomecmeters.com) (North America) to request more detailed application support.

When using an OM series meter for measurement of a flammable liquid, an OM meter with electronics option code 'RS' can be used with a remote mounted F130 batch controller (e.g. OM025S001-211RS).

For an integrally mounted F130 batch controller, an OM meter with electronics option code 'F31' should be used (e.g. OM025S001-816F31).



### OM Series Oval Gear Flowmeter

Available with digital pulse outputs for connection to any FLOMEC batch controller, or with an integrally mounted EB11 or F130, the OM series meters are recommended for many batch applications.

- Stainless steel for water, some chemical, and some solvent applications
- PPS (ryton) for water and some chemical applications (25mm/1" size only)
- Aluminium for diesel fuel and lubricants, and some solvent applications



### G2 Series Turbine flowmeters

Available with digital pulse outputs (electronics option code PO) for connection to any FLOMEC batch controller. Stainless steel housings are suited to measurement of water and some chemicals.



### TM Series turbine Flowmeters

Available with digital pulse outputs (electronics option code PO) for connection to any FLOMEC batch controller. PVC housings are suited to measurement of water.

## Selecting Valves

When selecting valves for use with a FLOMEC® batch controller the following points should be noted.

Valve selection can be a complex process, especially when dealing with aggressive chemicals, high viscosities, or high liquid pressures, so it is recommended that the user seeks guidance from a valve manufacturer/distributor.

- Selecting V1 (high flow valve) to be the same pipe-size as the flowmeter is usually a good rule of thumb. However, if the pressure from your pump or your head-tank is low, or the outlet flowrate of your system is critical to your process, then more detailed analysis is required to ensure an appropriate valve is selected.
- Select V2 (low flow valve) to be 1 or 2 pipe-sizes smaller than V1. Note that your low flow valve should produce a flowrate substantially lower than V1 in order to prevent a pressure spike at the completion of a batch. A throttling valve installed in-line with V2 will make this selection a lot less critical, as the low-flow circuit can be adjusted to avoid the pressure spike.
- Direct acting solenoid valves or indirect acting solenoid valves (also known as pilot-assisted solenoid valves) are the most common choices, particularly in systems using pipes smaller than 40mm / 1.5".
- For installations where compressed air is available it can be more economical to use pneumatically actuated ball valves, particularly when you have large diameter pipes. This is also the preferred option for installations batching flammable liquids as it keeps the electrical power to a minimum.
- Indirect acting solenoid valves are preferred when using solenoid valves for liquid control, as electrical power requirements are reduced and higher liquid pressures are possible.

Choice of valves will depend on many application factors, such as:

- Liquid in contact with the valve will determine the material of the valve body and the seals.
- The availability of electrical power and user preference will determine if 24VDC or mains AC power is used (230V or 115V) for control of the solenoid valves. Desire to avoid additional cost/complexity from external relays would require choosing a 24VDC or 12VDC solenoid valve.
- Valve type and liquid pressure will determine the power requirement for the solenoid coil. Higher liquid pressures require more opening force on the solenoid valve and therefore more electrical power.

→ In a single stage batching system, coil power below 10.8W at 24VDC would allow the user to avoid installing additional relays.

→ In a dual-stage batching system, coil power below 7.2W at 24VDC for both solenoid valves would allow the user to avoid installing additional relays.

• A common application batching water would often use a brass valve with an NBR or EPDM seat/seals, and a 24VDC / 8W solenoid coil. For example; part number 8240400.9101.02400 from IMI Buschjost.

## Selecting Relays

When using a FLOMEC® batch controller with high voltage DC solenoid valves, or with AC voltage solenoid valves, a relay is required. The function of the relay in this situation is to conduct the high voltage or high power to the valve, while allowing the outputs of the batch controller to operate at low power DC. The other benefit of this setup is that the relay isolates the electronics in the batch controller from the rest of the electrical system, protecting the controller from potential damage from power surges, lightning strikes, etc.

When selecting a relay to install with a FLOMEC® batch controller, the following factors should be considered:

- A non-latching general purpose relay should be used, one per solenoid valve is required. So for a dual stage system you will require two relays.
- Mechanical relays are the economical choice, however they will have a finite lifespan due to wear of the mechanical contacts. Solid state relays offer theoretically infinite lifespan, but at a higher price.
- SPST NO (single pole, single throw, normally open) relay type is recommended, however a SPDT (single pole, double throw) relay is also acceptable. If using a SPDT relay you must wire the solenoid coil circuit using the NO (normally open) terminal of the relay.
- The voltage rating of the relay must exceed the voltage required by the solenoid valve. If your solenoid valve is operating on 24VDC, select a relay with a voltage rating higher than 24VDC. For DC loads the voltage and current are at 100% whenever the valve is open, so a margin of safety on relay ratings is a good idea to prolong the life of the contacts. This is less critical on an AC circuit because AC voltages are not operating at full voltage/current constantly and are not as damaging to the relay contacts.
- For DC solenoid valve coils the power rating of the relay must exceed the power required by the coil.
- For DC solenoid valve coils the current rating of the relay must exceed the current draw from the coil. If the valve manufacturer only publishes the power rating of their solenoid coil you can determine the current draw using this equation:
$$\text{Current (Amps DC)} = \frac{\text{Power (W)}}{\text{Voltage (V)}}$$

For example, a 24VDC coil with a power rating of 18W will have a current draw of  $18/24 = 0.75$  Amps
- For AC solenoid valve coils the power rating in VA or kVA will be published by the valve manufacturer. The AC switching power rating for the relay must exceed the power rating of the solenoid valve coil.
- The coil voltage for the relay must be less than 30VDC; 24VDC and 12VDC are common and are both a good choice for use with a FLOMEC batch controller.
- The coil power must be less than 7.2W (most relays have coil power much lower than this).

Some options which will work with most solenoid valves are:

### Phoenix Contact | Part # 2903361

Type: Mechanical relay, single pole, single throw, normally open

DC Ratings: 250VDC, 140W, 6A

AC Ratings: 250VAC, 1500VA

Coil: 24VDC, 0.17W

### Omron | Part # G2RV-SR700 DC24

Type: Mechanical relay, single pole, double throw

DC Ratings: 125VDC, 180W, 6A

AC Ratings: 440VAC, 1500VA

Coil: 24VDC, 0.3W

### Schneider Electric | Part # SSM1A16BD

Type: Solid state relay, for AC loads, single pole, single throw, normally open

AC Ratings: 280VAC, 6A

Coil: 4-32VDC, 0.26W

# Designing a Pneumatic Control System

If your installation is in a facility where compressed air is available, it can be a reliable and cost effective option to use pneumatically controlled valves to control your liquid flow. When pipe sizes are large (50mm/2" and larger), electrically controlled solenoid valves can become expensive. Similarly, the power requirements for the solenoid coils can lead to larger and more expensive relays and wiring. Opting for pneumatic control of your liquid valves allows us to keep the electrical power to a minimum, removing the need for external relays and simplifying our electrical wiring.



Pneumatic control is also the recommended method for designing a batch control system which is safe for use with flammable liquids.

There are numerous ways to design a pneumatic control system, so the details listed below are only one way to design your system; and not the only way.

We recommend the below because it offers a simple and cost effective system that will fail closed in case of a loss of power or pneumatic pressure.

- A normally closed, spring return, 3/2 pneumatic solenoid valve is required to switch the pneumatic pressure to your liquid control valves. One pneumatic solenoid valve is required for each liquid control valve. An exhaust silencer will be required for each pneumatic solenoid valve.
- Liquid control valves can be selected as ball valves, butterfly valves, angle-seat valves, or others. The type of liquid control valve is generally determined by user preference and cost. Any valve distributor/supplier will be able to supply a valve that will be suited to your process requirements.

- We recommend that liquid control valves are fitted with a single-acting pneumatic actuator which is spring closed. This means that if pneumatic pressure is lost due to a burst hose or a failed compressor that your liquid flow will automatically stop.
- Other accessories that may be required, depending on the existing equipment installed at your facility are; pressure regulator, pneumatic pressure gauge, air filter, air dryer.

Some options for pneumatic solenoid valves are:

**SMC** | Part # VP342.5Y001-02FA

**Festo** | Part # VUVS-LK25-M32C-AD-G14-1B2-S

If you are working with flammable liquids or in a hazardous area, specialty pneumatic solenoid valves will be required. One option for an appropriately certified valve which can be used in countries that accept IECEx or ATEX certification schemes is:

**IMI Heroin** | Part # 9713535.2050.02400

When installing in a hazardous area, electrical power for the batch controller and pneumatic solenoid valves must be supplied by an intrinsically safe barrier. The intrinsically safe barrier acts as a limiter on the electrical energy that can enter the hazardous area, in order to prevent the creation of sparks which could ignite flammable gasses or vapours.



Please contact a distributor for MTL or Peppel & Fuchs to determine an appropriate intrinsically safe barrier to use in your application

# Electrical System Layout

Single stage system, using a 24VDC solenoid valve, coil power <math><10.8W</math>

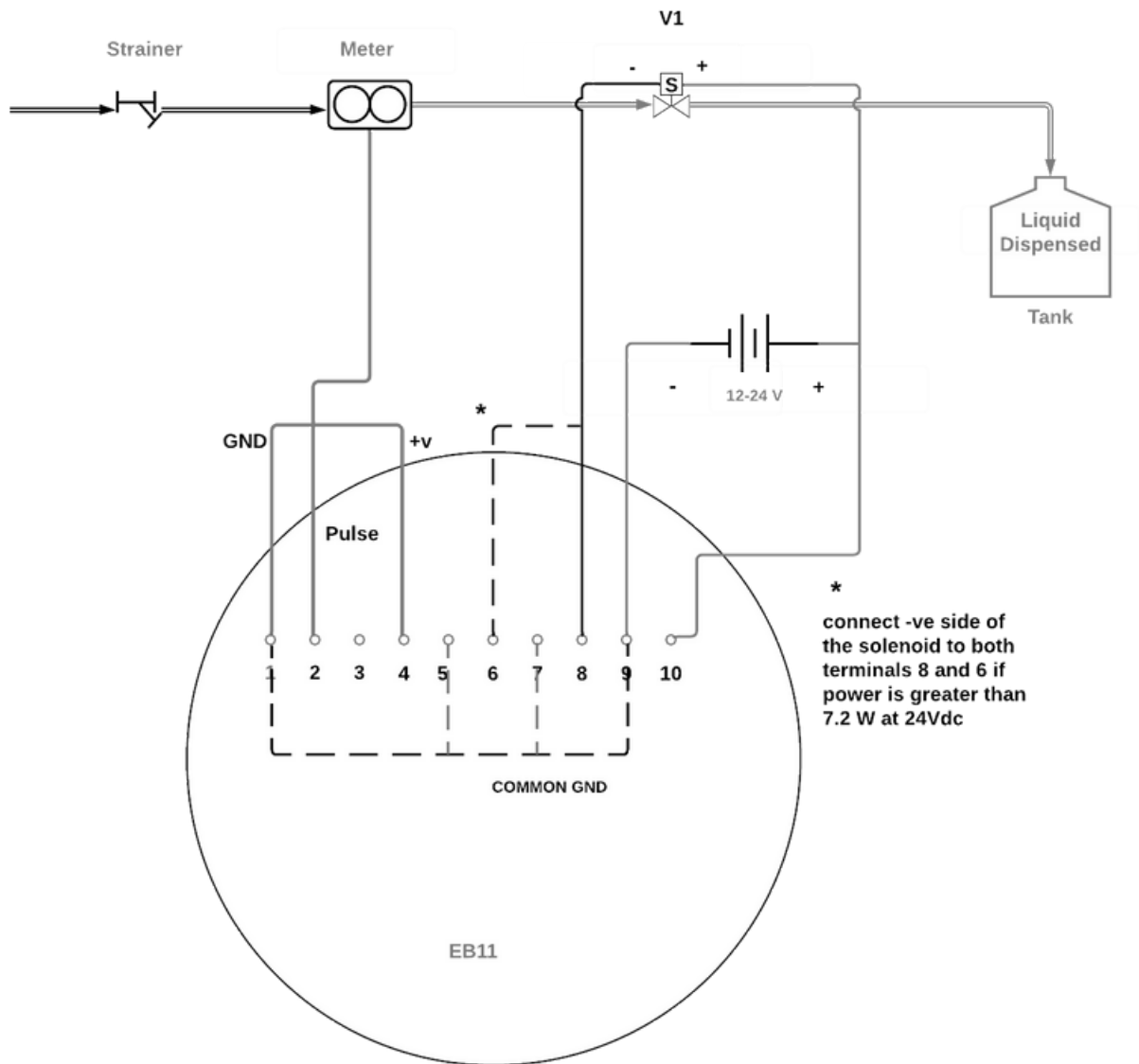

Note: 'PRECLOSE' software setting should be set to zero for single stage batch control

## Single stage system using a high-power DC solenoid valve, or AC solenoid valve

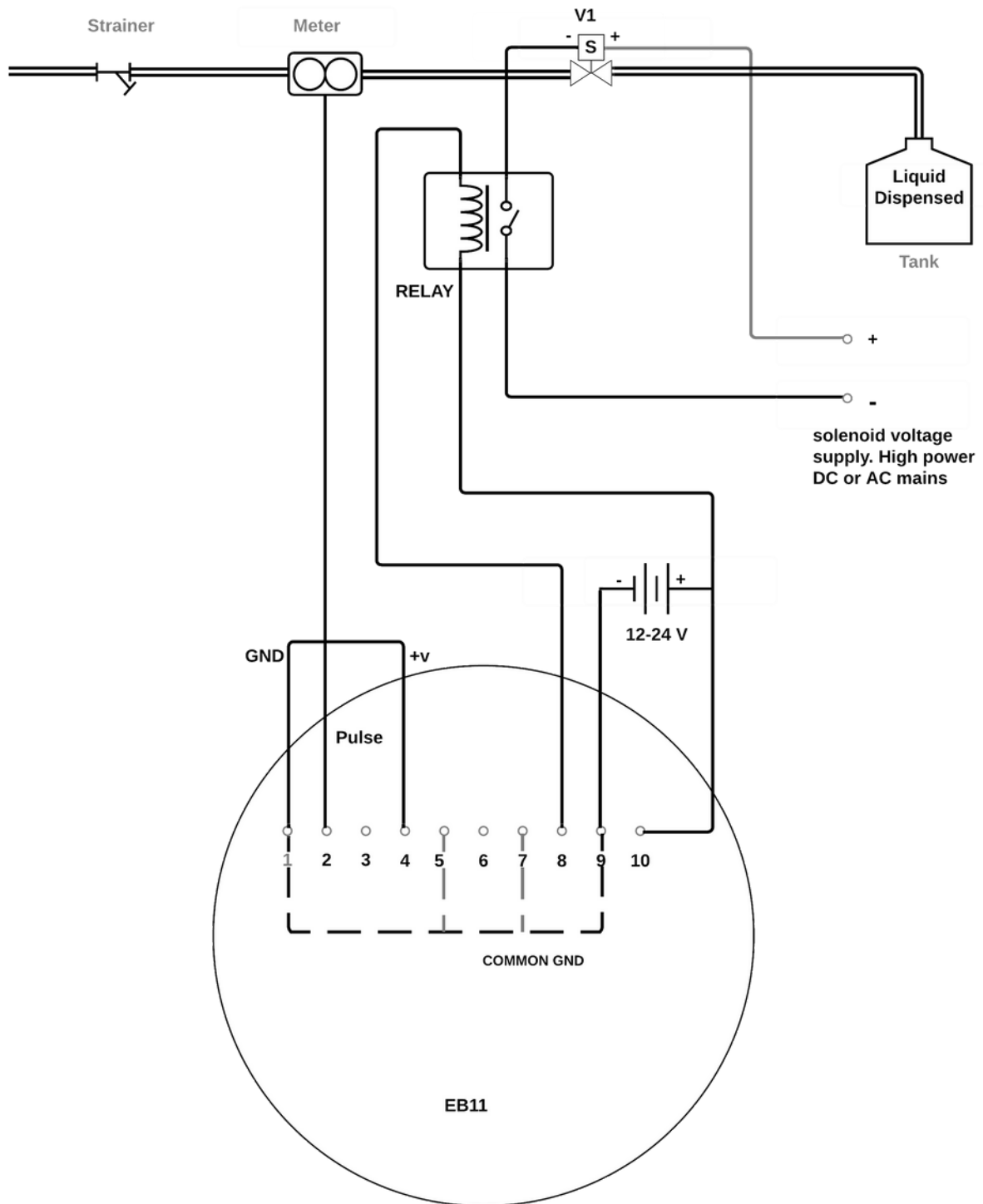

Note: 'PRECLOSE' software setting should be set to zero for single stage batch control



## Dual stage system using 24VDC solenoid valves, coil power < 7.2W

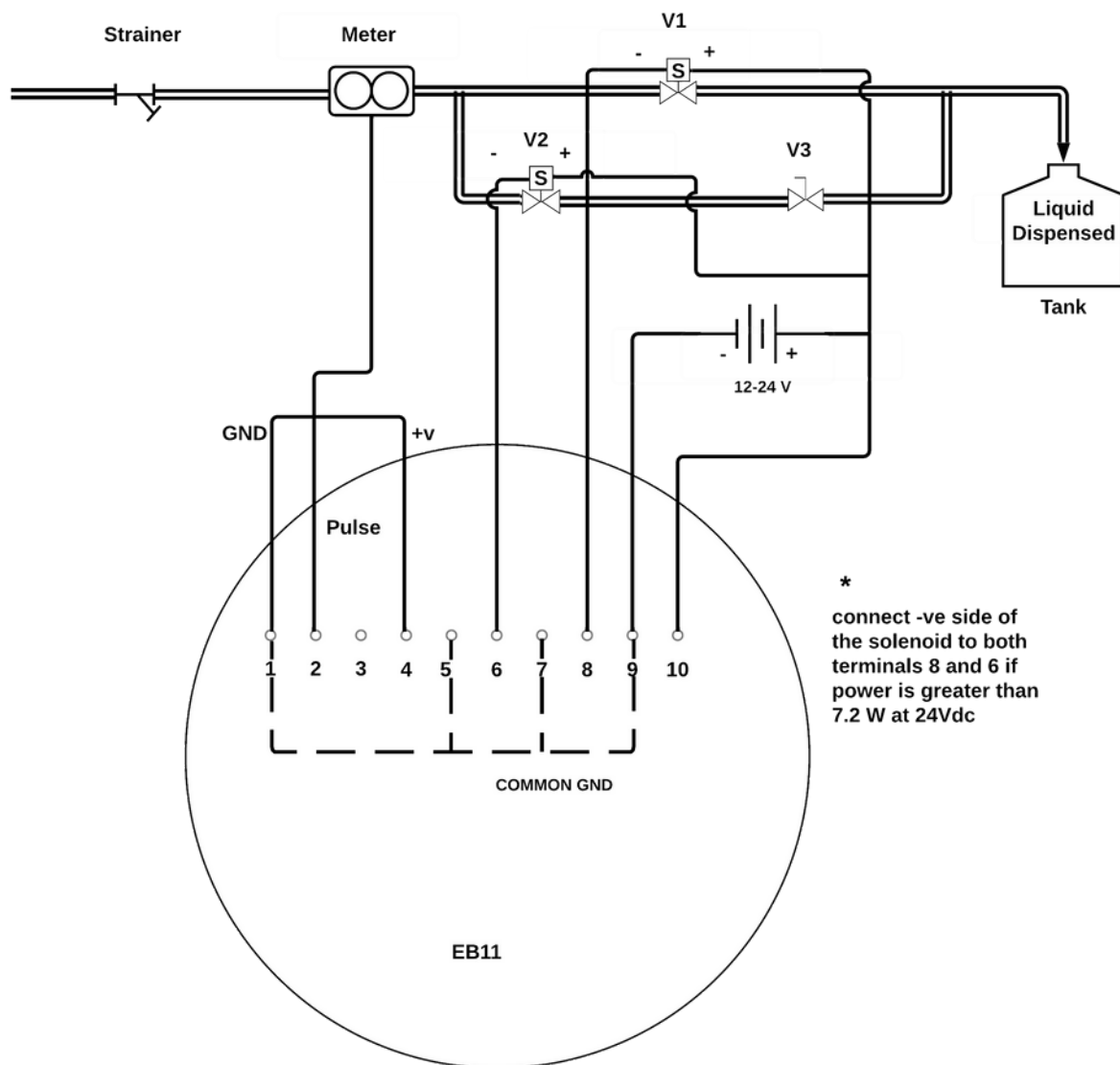

## Dual stage system using a high-power DC solenoid valve, or AC solenoid valve

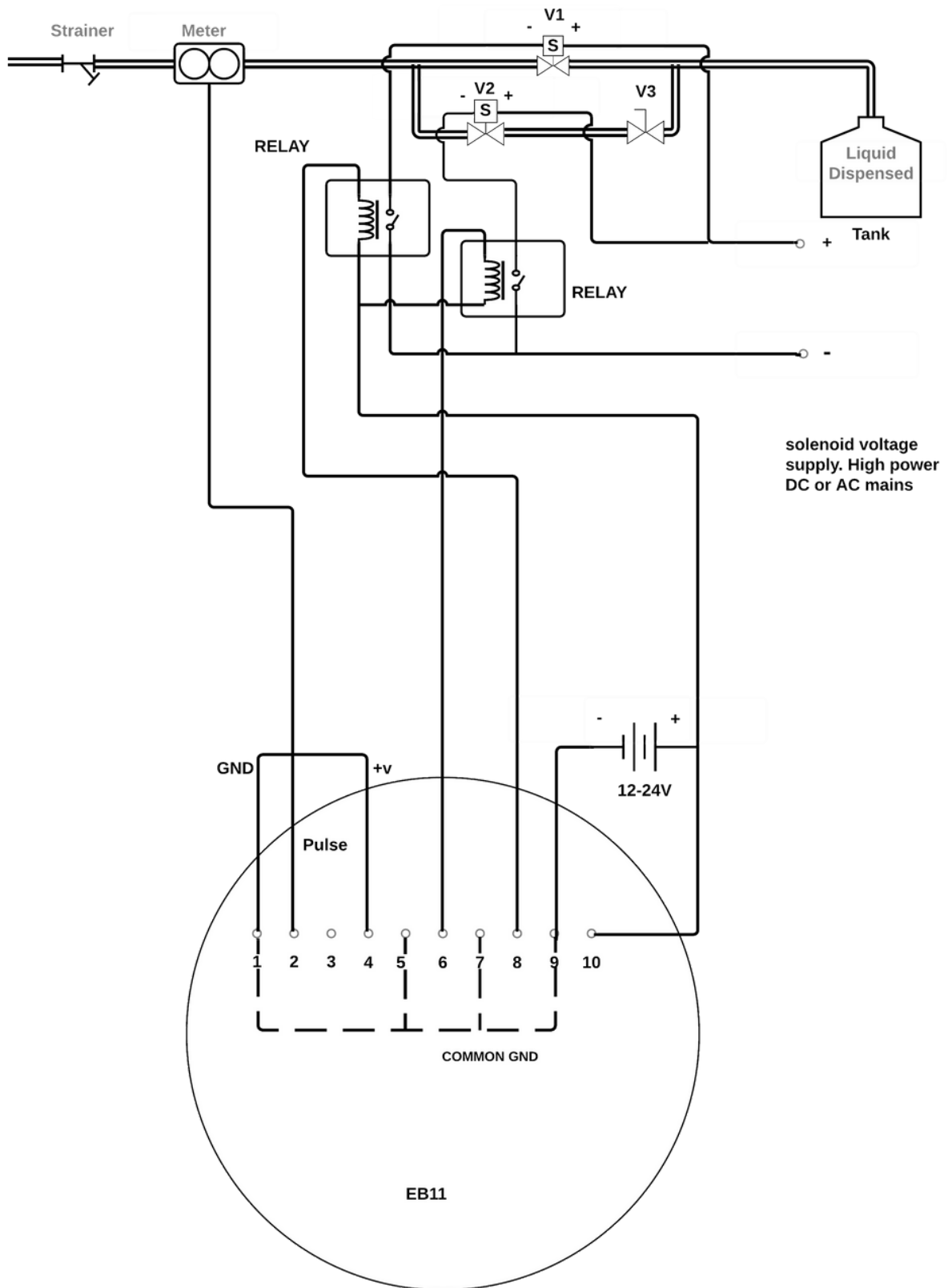

## Single stage system using a pneumatic valve (safe area)

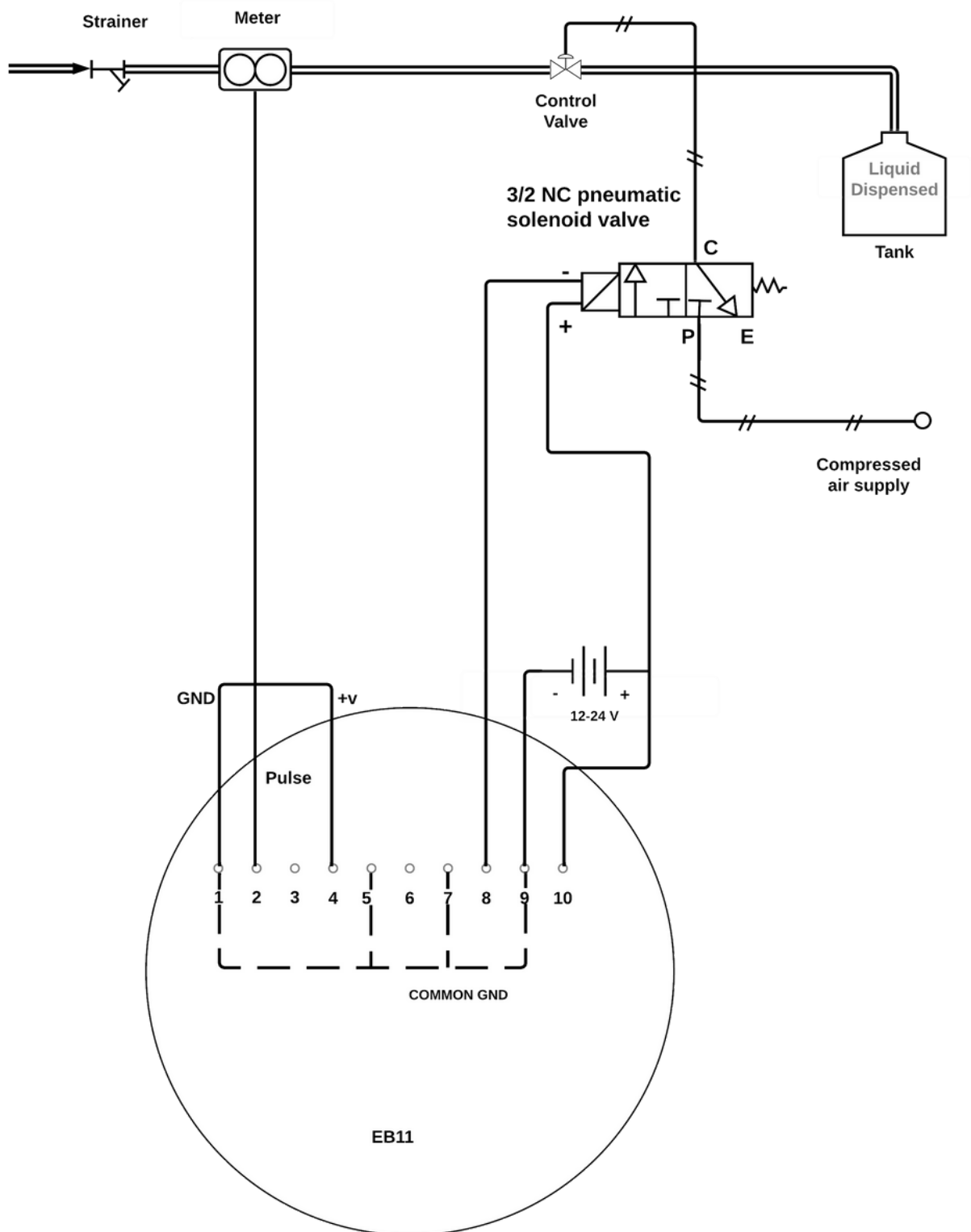

Note: 'PRECLOSE' software setting should be set to zero for single stage batch control

## Dual stage system using pneumatic valves (safe area)

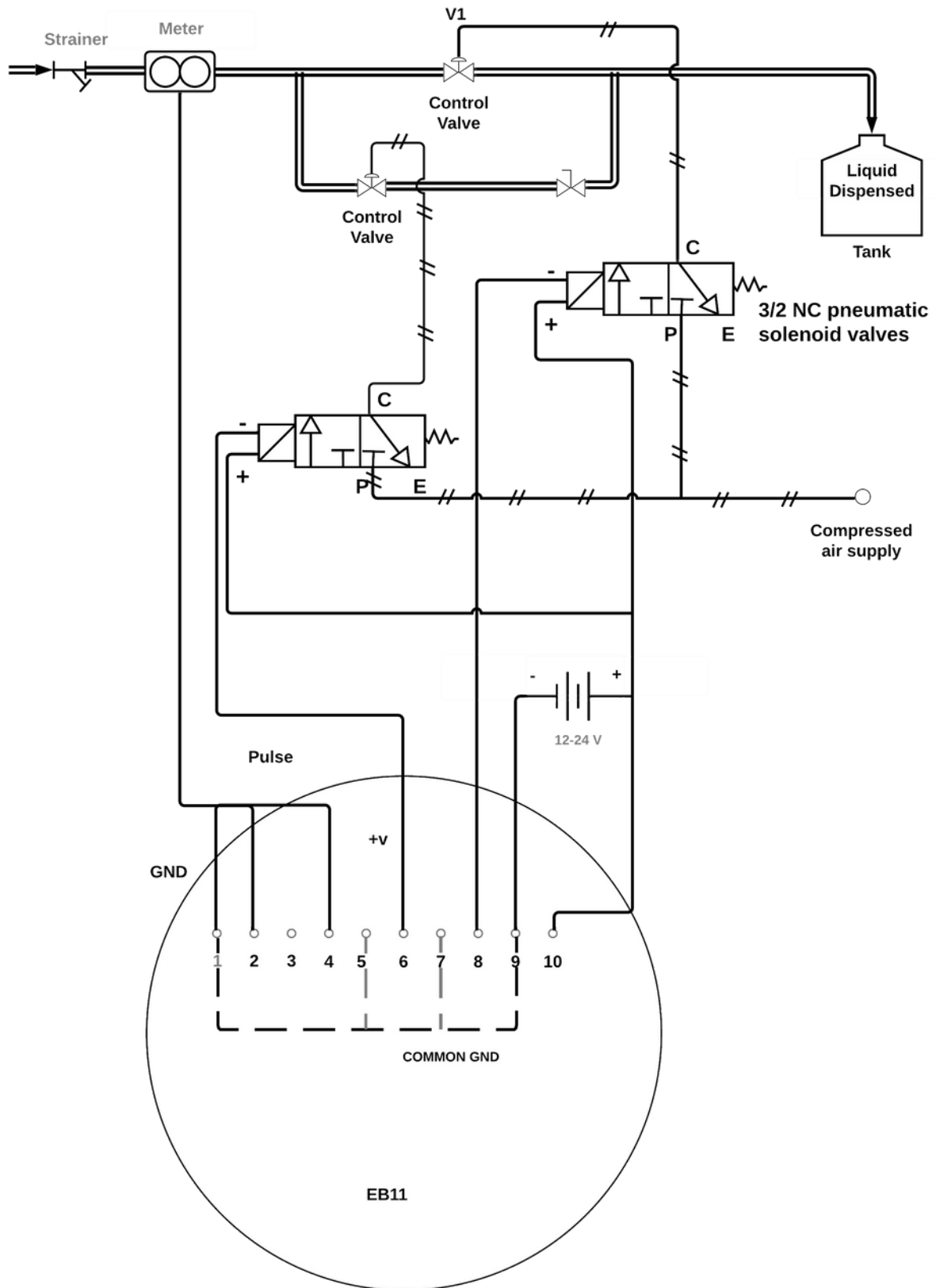

## Single stage system using a pneumatic valve (hazardous area)

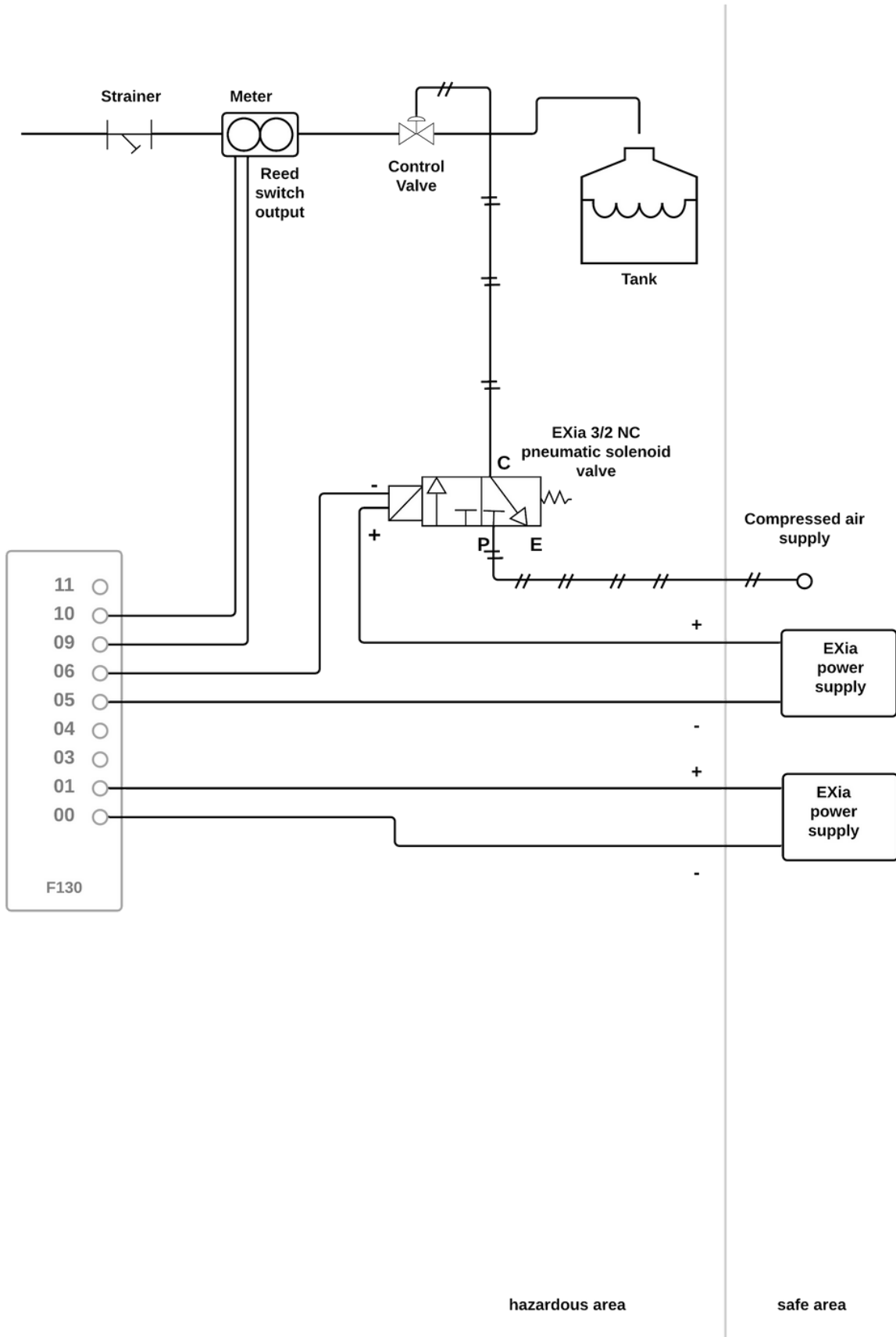

## Dual stage system using pneumatic valves (hazardous area)

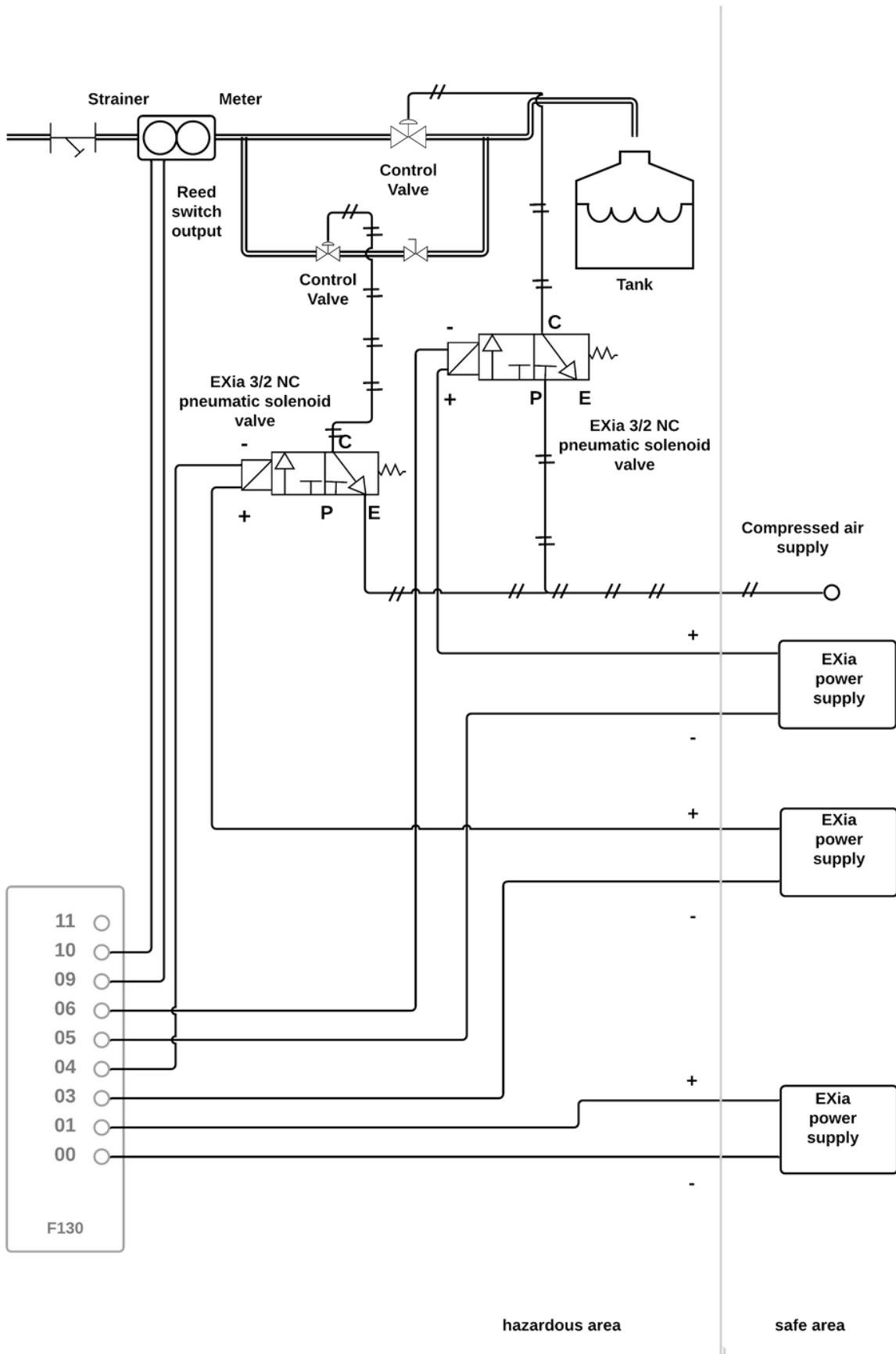



# Glossary

**Direct acting solenoid valve** – An electrically actuated valve where the plunger that blocks the flow of liquid is directly moved by the solenoid coil. This type of solenoid valve does not require any difference in pressure between inlet and outlet in order to operate.

**Indirect acting solenoid valve** – An electrically actuated valve which uses the pressure from the fluid to open and close the valve. Usually the element which opens/closes the valve is a diaphragm or a piston. This type of valve requires a pressure difference between inlet and outlet in order to provide the force to open the valve seat. This type of valve requires less electrical power to open, therefore higher liquid pressures and larger valves are possible with only a small solenoid coil.

**Hazardous area** – An area/location in which an explosive atmosphere may be present. An explosive atmosphere is defined as a mixture of air with a flammable or dangerous substance in the form of gases, vapours, mist or dust. If ignition occurs in an explosive atmosphere, due to a spark or a hot surface, combustion spreads to the entire unburnt mixture creating an explosion. Hazardous areas usually exist where flammable liquids, gases, vapours, or combustible dusts are used or stored.

**Safe area** – An area/location in which an explosive atmosphere cannot be present. Safe areas usually exist when there is no handling/use/storage of flammable liquids, gases, vapours, or combustible dusts occurs.

**Foot valve** – A special design of check valve, or non-return valve, which is designed for fitment to the suction side of a pump (inlet side). Foot valves prevent the draining of piping when the pump is off, keeping the piping full of liquid, and preventing the pump from losing prime.

**Gravity fed system** – Systems where the liquid pressure is provided by earth's gravity acting on a tank of liquid which is situated higher than the outlet of the system.

**Simple Apparatus** – A simple apparatus is a passive electrical component such as a switch, junction box, resistors, thermocouple, or simple semiconductor, with well defined electrical properties and low levels of stored energy. A simple apparatus may be used in some hazardous area electrical systems without certification.

**IECEx** – The IEC system for certification of equipment for use in explosive atmospheres. It uses assessments and standard specified by the International Electrotechnical Commission (IEC). IECEx is the accepted scheme for controlling the safety of hazardous area electrical equipment in various countries around the world, including Australia and New Zealand.

**ATEX** – "Appareils destinés à être utilisés en ATmosphères EXplosives" (French for Equipment intended for use in EXplosive ATmospheres). The European Union scheme for controlling the safety of hazardous area electrical equipment.

**FM** – Factory Mutual, an insurance underwriter in the United States of America which oversees the scheme for controlling the safety of hazardous area electrical equipment for the USA.

**Intrinsically safe barrier** – Intrinsically safe barriers are devices that limit the energy that is supplied to a circuit inside a hazardous area. Intrinsically safe barriers are a safety device that facilitates the connection of intrinsically safe devices inside a hazardous area, to non-intrinsically safe circuits in a safe area.

**EXia** – An abbreviation for equipment which is certified as intrinsically safe.



Sydney, Australia

[www.flomec.com.au](http://www.flomec.com.au)

12/7-11 Parraweena Road  
Caringbah, NSW 2229  
Australia

Wichita, United States

[www.flomecmeters.com](http://www.flomecmeters.com)

5252 E 36th ST N  
Wichita, Kansas 67220  
United States

Design guides, data sheet and other product information is available by emailing us or contacting your sales representative. Always consult the appropriate documentation before using any of our products.

Neither FLOMEC nor any of its affiliates makes any warranty, express or implied, including merchantability or fitness for use, or accepts any liability in connection with recommended products from companies other than FLOMEC, related information or its use. Some applications of which FLOMEC's products may be proposed to be used are regulated or restricted by applicable laws and regulations or by national or international standards and in some cases by FLOMEC's recommendation, including applications of food/feed, water treatment, medical, pharmaceuticals, and personal care.

The user must finally determine suitability of any information or products for any contemplated use in compliance with applicable law, the manner of use and whether any patents are infringed. The information and the products are for use by technically skilled persons at their own discretion and risk and does not relate to the use of this product in combination with any other substance or any other process. This is not a license under any patent or other proprietary right.

All trademarks and registered trademarks are property of the companies that comprise Great Plains Industries.  
© 2021, Great Plains Industries. All rights reserved.