

*icountPD*



## icountPD User Manual



B.84.833\_IPD\_EN Rev 3

© 2015, Parker Hannifin Corporation

[www.parker.com/hfde](http://www.parker.com/hfde)

# Contents

<b>icountPD User Manual .....</b>	<b>1</b>
Laser Information .....	3
EC Declaration of Conformity .....	4
<b>Introduction .....</b>	<b>5</b>
Principles of operation.....	5
Benefits .....	6
Technical specification .....	7
Software default settings.....	8
Product features .....	9
Dimensions for installation.....	9
<b>Connections.....</b>	<b>10</b>
Hydraulic connection .....	10
Flow control .....	10
System 20 sensor connection.....	11
Electrical connections .....	12
Variable current output settings.....	26
Variable voltage output settings.....	27
CAN-bus network output option .....	27
Moisture sensor output settings .....	27
RS232 connectivity .....	28
<b>Software .....</b>	<b>29</b>
icountPD Setup Utility software.....	29
Microsoft Windows® HyperTerminal connection .....	32
Communication protocol.....	34
<b>Front panel displays .....</b>	<b>38</b>
LED display parameters (ISO4406 / NAS1638) .....	38
Digital display parameters (ISO 4406 / NAS 1638) .....	39
<b>Reference .....</b>	<b>42</b>
Optional wiring configuration.....	42
Optional limit relay hysteresis .....	42
Contamination Standards .....	44
Viscosity charts.....	45
icountPD-CAN version, SAE J1939 technical note .....	46
Ordering Information .....	49

## Laser Information

This product contains an infrared 5mW laser.

Any dismantling of the product may result in dangerous exposure to laser radiation. The following laser information is on a label on the top surface of the product:



---

**CAUTION:** *Users are not required to access the laser radiation source and should never do so.*

---

The internal laser warning label is mounted on the laser module and contains the following information:

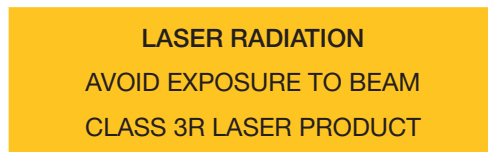

# EC Declaration of Conformity

## **EC Declaration of Conformity**

Document No. DoC0001-issue 3



Parker Hannifin (UK) Ltd  
Hydraulic Filter Division Europe  
Condition Monitoring Centre  
Brunel Way, Thetford, Norfolk  
IP24 1HP, United Kingdom

### **Product(s):**

*The following icountPD products have been approved:*

- *icountPD compatible with mineral, aggressive oils and aviation fuels*
- *icountPD calibrated with ACFTD and MTD*
- *icountPD with or without a display (LED or digital)*
- *icountPD with or without a limit relay*
- *icountPD with RS232, 4-20mA, 0-3/0-5V and CANBUS (J1939) outputs*
- *icountPD with or without a Moisture Sensor*
- *icountPD fitted with the fixed 5 metre cable, Deutsch connector or M12 connector.*

### **The Product(s) described above are in conformity with the essential requirements of the following directives:**

*89/336/EEC amended by 92/31/EEC, 93/68/EEC and repealed by 2004/108/EEC*

### **Harmonised standards:**

*EN61000-6-3:2001 Electromagnetic compatibility – Part 6-3: Generic standards – Emission standard for residential, commercial and light-industrial environments.*

*EN61000-6-2:2001 Electromagnetic compatibility (EMC) – Part 6-2: Generic standards – Immunity for industrial environments*

Signed for and on behalf of Parker Hannifin (UK) Ltd, Thetford  
13<sup>th</sup> May 2008

Steve Newcomb  
Operations Manager

CMC E12 Issue 1, May 07

# Introduction

Parker Hannifin's icountPD represents the most up-to-date technology in solid particle contamination analysis. The icountPD is a compact, permanently-mounted laser-based particle detector module that provides a cost-effective solution to fluid management and contamination control.

## Principles of operation

The icountPD measures particle contamination continuously and updates the display, output options and limit relay every second.

Unlike the Parker CM20, LCM20 or MCM20, the unit does not perform a 'one-off' test. This means that even if the Measurement Period is set to 60 seconds, the display, output and limit relay all report the presence of dirt in the oil in just a few seconds – it does not wait until the end of the Measurement Period before reporting the result.

The icountPD has just one setting to control the accuracy, stability and sensitivity of the measurements and that is the 'Measurement Period'. This can be set from five seconds to 180 seconds. The longer the Measurement Period, the more contaminant is measured, averaging out any spikes seen on a smaller sample. The shorter the Measurement Period the more sensitive the icountPD is to small slugs of contaminant, but also the performance on clean systems can be reduced. Thus, the user can select how sensitive the icountPD is to spikes of contaminant, and how quickly it responds to contamination levels above the set point ('limits').

With a Measurement Period of 100 seconds, the results will be for the last 100ml of oil that has flowed through the icountPD, updated on a second-by-second basis, giving an effectively continuous readout of the level of contamination.

## Calibration recommendations

Contact your local Parker Hannifin Sales Company for recalibration details. The recommended period between recalibration is 12 months.

Refer to the Parker Hannifin Quality and Servicing booklet (FDCB272UK), supplied on CD.

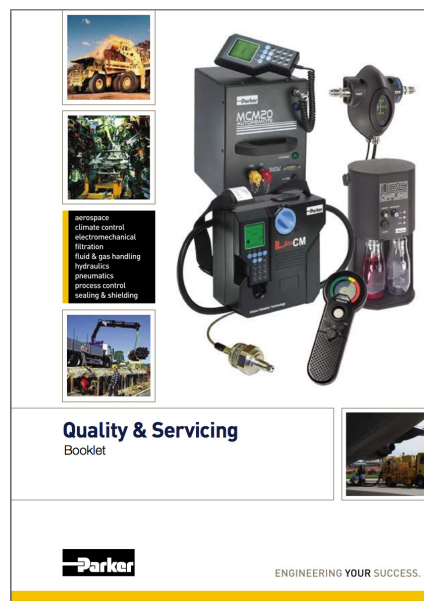

## Maintenance requirements

Ensure that the power supply is disconnected before any maintenance/inspection is carried out. Please contact Parker Hannifin in the unlikely event of the icountPD being faulty or damaged.

## Storage requirements

Store in dry conditions within a temperature range of -20°C to +40°C (-4°F to +104°F).

## Benefits

- Independent monitoring of system contamination trends
- Calibration by recognised online principles confirmed by relevant International Organization for Standardization (ISO) procedures
- Early warning LED or digital display indicators for Low, Medium and High contamination levels
- A low cost solution to prolonging fluid life and reducing machine downtime
- Visual indicators with power and alarm output warnings
- Self-diagnostic software
- Mineral and phosphate ester fluid compatible construction – see ‘Ordering Information’ on page 46, for fluid type options
- Fully PC/PLC integration technology such as: RS232, 0–3V/0–5V, 4–20mA and CAN-bus (SAE J1939) – see ‘Ordering Information’ on page 46, for communication options
- Percentage saturation reporting through an integrated moisture sensor – see ‘Ordering Information’ on page 46, for moisture sensor options.

## Technical specification

Feature	Specification
Product start-up time	5 seconds minimum
Measurement period	5–180 seconds
Reporting interval	0–3600 seconds via RS232 communication
Principle of operation	Laser Diode optical detection of actual particulates
International codes	ISO 7 – 22, NAS 0 – 12
Calibration	By recognised online methods confirmed by the relevant ISO procedures. <b>MTD</b> – Via a certified primary ISO 11171 automatic particle detector using ISO 11943 principles, with particle distribution reporting to ISO 4406:1996 <b>ACFTD</b> – Conforming to ISO 4402 principles with particle distribution reporting to ISO 4406:1996
Recalibration	Contact Parker Hannifin
Working pressure	2–420 bar (30–6000 PSI)
Flow range through icountPD	<b>Note:</b> Flow may be bi-directional 40–140 ml/min (optimum flow 60 ml/min) (0.01 – 0.04 USGPM (optimum flow 0.016 USGPM))
Online flow range via System 20 sensors	Size 0 = 6 to 25 l/min (2–7 USGPM) Size 1 = 24 to 100 l/min (6–26 USGPM) Size 2 = 170 to 380 l/min (45–100 USGPM)
Ambient storage temperature	–20°C to +40°C (–4°F to +104°F)
Environment operating temperature	+5°C to +60°C (+41°F to 140°F)
Fluid operating temperature	+5°C to +80°C (+41°F to 176°F)
Computer compatibility	Parker recommends the use of a 9-way D-type connector. This can be connected to a USB port using a USB-serial adaptor. Note that these connectors/adaptors are <b>NOT</b> supplied with icountPD units: contact Parker Hannifin for advice.
Moisture sensor calibration	±5% RH (over compensated temperature range of +10°C to +80°C; +50°F to +176°F)
Operating humidity range	5% RH to 100% RH
Moisture sensor stability	±0.2% RH typical at 50% RH in one year
Power requirement	Regulated 9–40Vdc
Current rating	Typically 120mA
Certification	IP66 rating Refer to the EC Declaration of Conformity (page 2).
<b>Analogue output options (specified when ordering)</b>	
Variable current	4–20mA
Variable voltage	0–5Vdc, 0–3Vdc (user selectable)
CAN-bus	to SAE J1939 (e.g. <i>Parker IQAN</i> )
Moisture sensor	Linear scale within the range 5% RH to 100% RH

## Software default settings

Standard defaults	
Comms echo	OFF
Verbose errors	OFF
STI Sensors used	OFF
Reporting standards	ISO
Particle limits	19 / 18 / 15
Measurement period	60 seconds
Reporting interval	30 seconds
Power-on mode	AUTO
Auto start delay	5 seconds
Date format	dd/mm/yy

Default if options fitted	
Relay hysteresis	ON
Relay operation for particle limits	ON
Relay operation for moisture sensor limits	ON
Digital display orientation	0 degrees
Digital display brightness level	3-mid
0–5V/0–3V output voltage range	0–5V
Moisture sensor limit	70%



## Product features

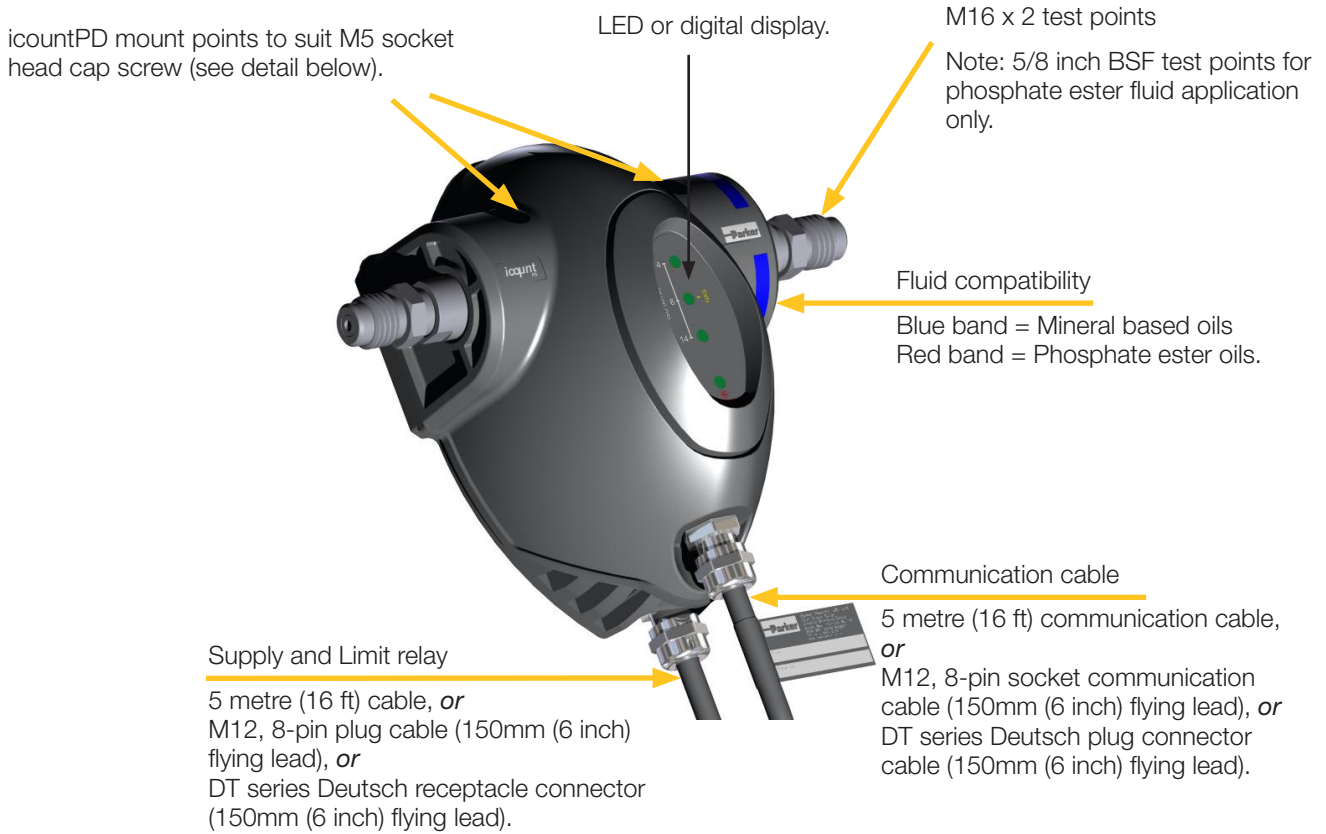

## Dimensions for installation

Dimensions are given in mm (inches)

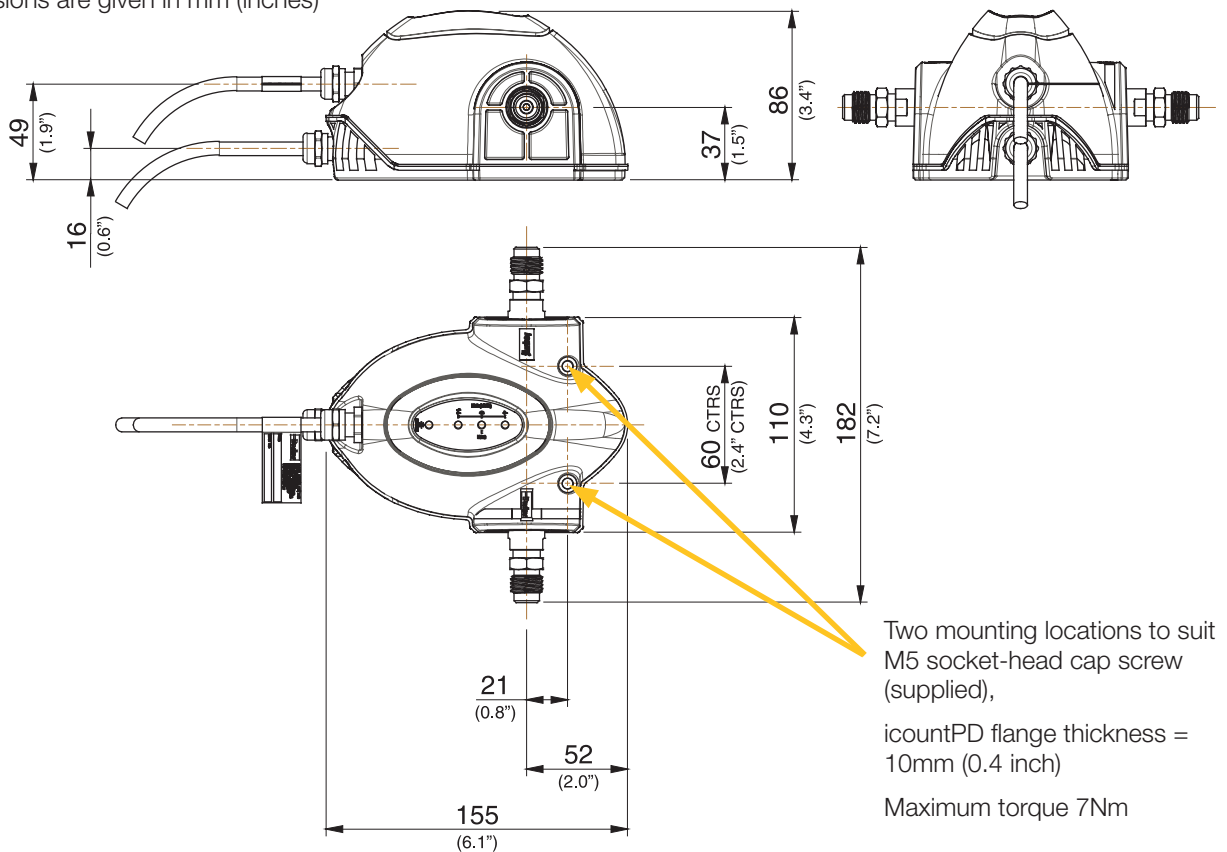

# Connections

## Hydraulic connection



Our recommendation is to position the icountPD as close to the system output as possible whilst controlling the flow to the optimum 60ml/min. This then provides the highest pressure conditions, plus the oil in this position is indicative of the reservoir's oil condition.

For transportation, the icountPD is supplied with two test point covers: these need to be removed.

The mineral oil version of icountPD is supplied with M16 x 2 hydraulic test points. Parker recommends that these are **not removed or loosened**. If these test points are not required please contact Parker Hannifin for alternative options.

Note that the phosphate ester oil version of the icountPD is supplied with 5/8 inch BSF hydraulic test points.

For Hydraulic connection:

1. Connect two pressure hoses to either end of the icountPD test points.
2. Connect the opposite end of the pressure hoses to the application.

---

**NOTE:** The connection of these test points should be 'finger tight' only. Do not use spanners or wrenches.

---

## Flow control

A pressure compensated, flow control device (Parker Hannifin part number S840074) has been developed to give the icountPD user greater flexibility. The flow control device enables testing where flow ranges are outside the icountPD specifications (i.e. 40–140 ml/min), or where pipe diameters do not allow the icountPD to be installed.

### REQUIRED DIFFERENTIAL PRESSURE RANGE 5–315 BAR

The flow control device fits onto the downstream (outlet) side of the icountPD, connecting through a manifold block via a self-sealing quick connection test point.

The differential pressure valve automatically compensates for pressure and viscosity changes, whilst maintaining its flow setting even as the workload changes.

The table below is used to select the appropriate valve position:

Valve position	cSt range
3	20–100
3.8	90–200
4.2	190–320
5	310–500



## System 20 sensor connection

Online flow range via System 20 inline sensors:

<b>Size 0</b>	6 to 25 l/min (optimum flow = 15 l/min)
<b>Size 1</b>	24 to 100 l/min (optimum flow = 70 l/min)
<b>Size 2</b>	170 to 380 l/min (optimum flow = 250 l/min)

The required differential pressure across inline sensors is 0.4 bar (minimum)

Refer to the 'Sensor part numbers' section on page 46 before ordering System 20 sensors.

See 'Inline Sensor Monitors' (Parker Hannifin Brochure CM013GB1) for more information on System 20 sensors.

Size 0 Sensor

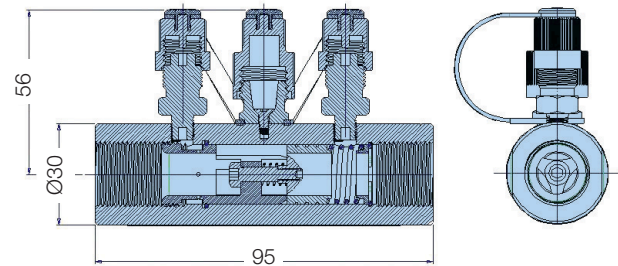

Size 1 Sensor

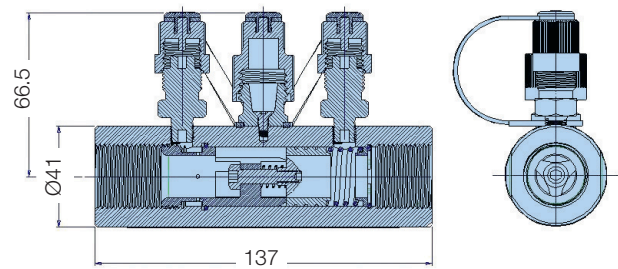

Size 2 Sensor

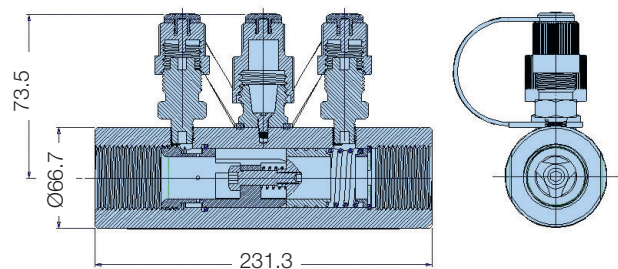

(All dimensions are in millimetres)

**IMPORTANT NOTE:** P1 and P2 of the System 20 sensors **MUST** be connected to the icountPD test points. Ensure that the icountPD command 'SSU' is set to 'Yes' when connecting to icountPD – refer to 'Communication protocol' section of this manual for a list of user commands.

Contact Parker Hannifin if you require further advice in connecting icountPD to your system.

## Electrical connections

The icountPD has a Communications cable (in front) and a Supply and Limit relay cable (behind).

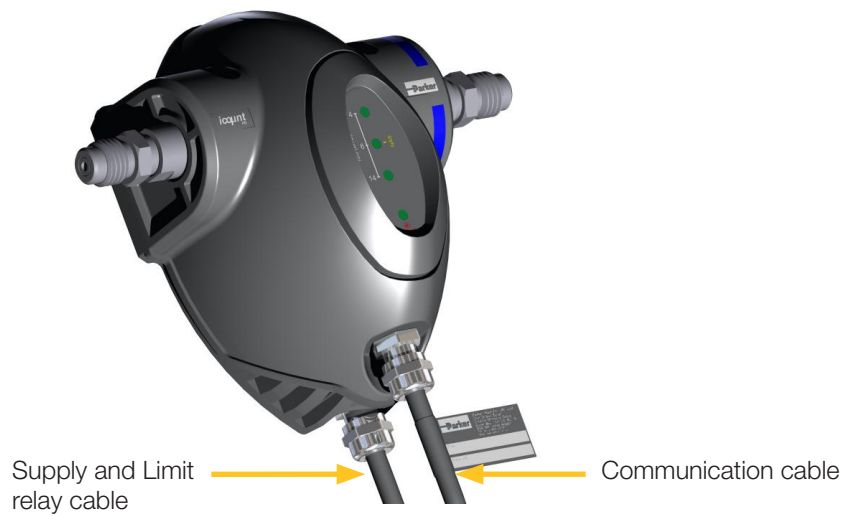

Depending on user requirements and the type of installation, the two cables may be supplied in 5m lengths and unterminated, or supplied in much shorter lengths and terminated with industry-standard connectors, as in the following table:

### CABLES AND CONNECTORS AVAILABLE

Connector type; Cable length	Communications cable: cable termination	Supply and Limit relay cable: cable termination
No connector; 5m (16 ft) cable	12-way, no connector	3-way, no connector
M12; 150mm (6 inch) cable	8-pin M12 socket	8-pin M12 plug
Deutsch DT-series; 150mm (6 inch) cable	12-pin Deutsch DT receptacle connector	12-pin Deutsch DT plug connector

### WIRING DIAGRAMS

For each type of termination, a wiring diagram is provided showing how a digital multimeter may be connected to both the Communication and the Supply and Limit relay cables. The connections for an optional moisture sensor (if fitted), are also shown.

Two variants (voltage measurement and current measurement) are shown for each type of cable termination.

## 5 metre cable (no connector): Communication cable

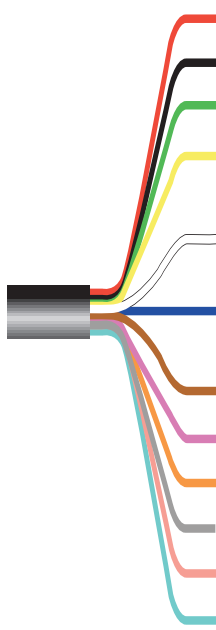

Wire colour	No options fitted	4–20mA option fitted	0–5V/0–3V option fitted	CAN option fitted
Red	Product supply 9–40Vdc	Product supply 9–40Vdc	Product supply 9–40Vdc	
Black	Product supply 0Vdc	Product supply 0Vdc	Product supply 0Vdc	
Green	NOT USED	Channel A ISO 4µm (c)	Channel A ISO 4µm (c)	CAN (Hi)
Yellow	NOT USED	Channel B ISO 6µm (c) or NAS (if selected)	Channel B ISO 6µm (c) or NAS (if selected)	CAN (Lo)
White	NOT USED	Channel C ISO 14µm (c)	Channel C ISO 14µm (c)	
Blue	NOT USED	Moisture sensor channel (if fitted)	Moisture sensor channel (if fitted)	CAN Ground
Brown	NOT USED	4–20mA Supply 12–20Vdc	0–5V / 0–3V Supply 12–24Vdc	
Violet (purple)	NOT USED	NOT USED	0–5V / 0–3V Supply 0 Vdc	
Orange	RS232 Ground (* Pin 5)	RS232 Ground (* Pin 5)	RS232 Ground (* Pin 5)	RS232 Ground (* Pin 5)
Grey	RS232 Receive (* Pin 3)	RS232 Receive (* Pin 3)	RS232 Receive (* Pin 3)	RS232 Receive (* Pin 3)
Pink	RS232 Transmit (* Pin 2)	RS232 Transmit (* Pin 2)	RS232 Transmit (* Pin 2)	RS232 Transmit (* Pin 2)
Turquoise (cyan)	NOT USED	NOT USED	NOT USED	

*NOTE: If the moisture sensor is fitted without either 4–20mA or 0–5V/0–3V option then the output is via RS232.*

*\* NOTE: Parker Hannifin recommends the use of a 9-way, D-type socket for use with RS232 with the stated pin configuration*

***IMPORTANT NOTE: It is the responsibility of the end user to ensure that the cable's braided screen is terminated to a suitable earth bonding point.***

## 5 metre cable (no connector): Supply and Limit relay cable (if fitted)

Wire colour	Standard
Red	Normally open
Blue	Normally closed
White	Common

## 5 metre cable (no connector): Voltage measurement

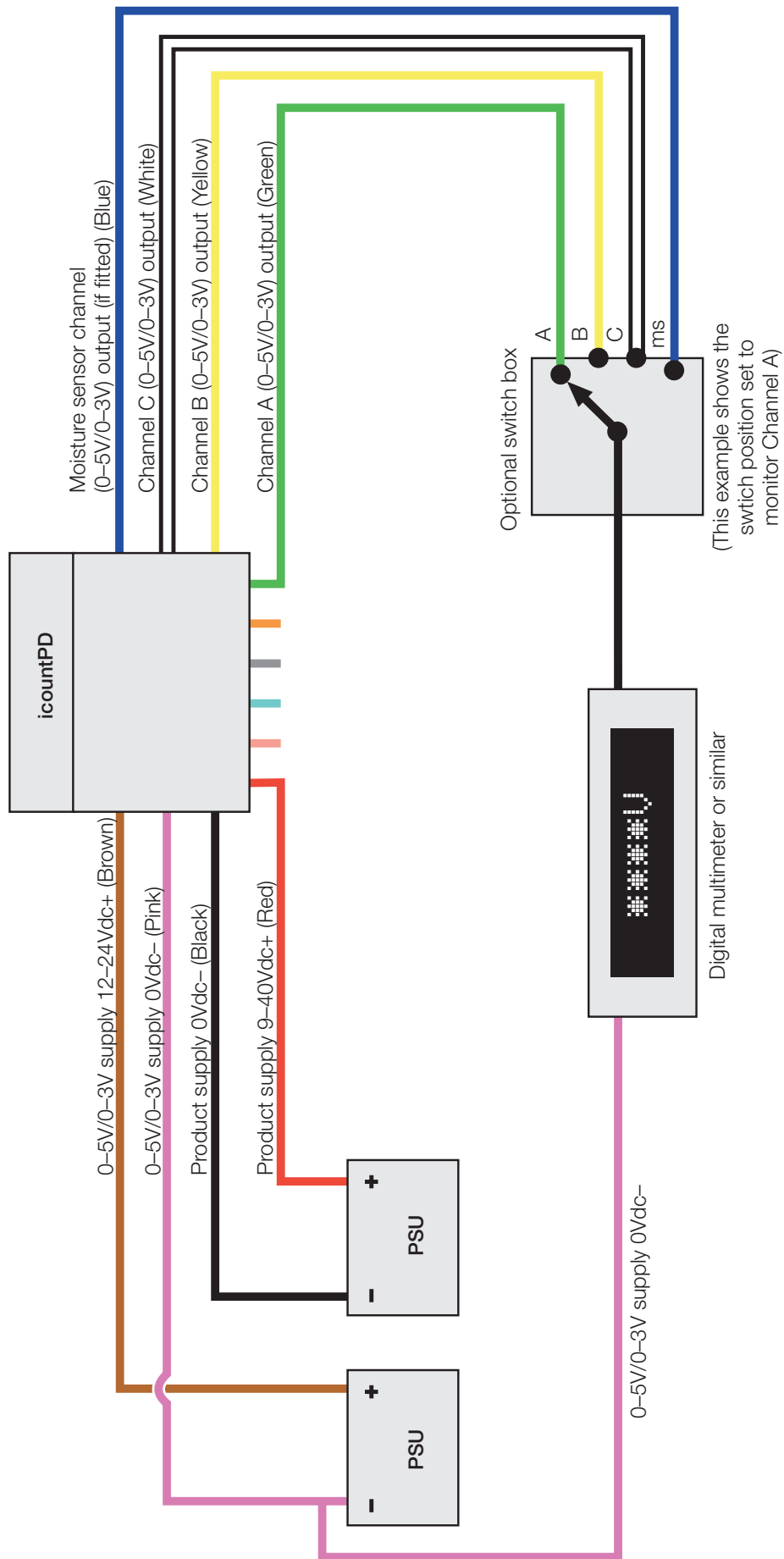

## 5 metre cable (no connector): Current measurement

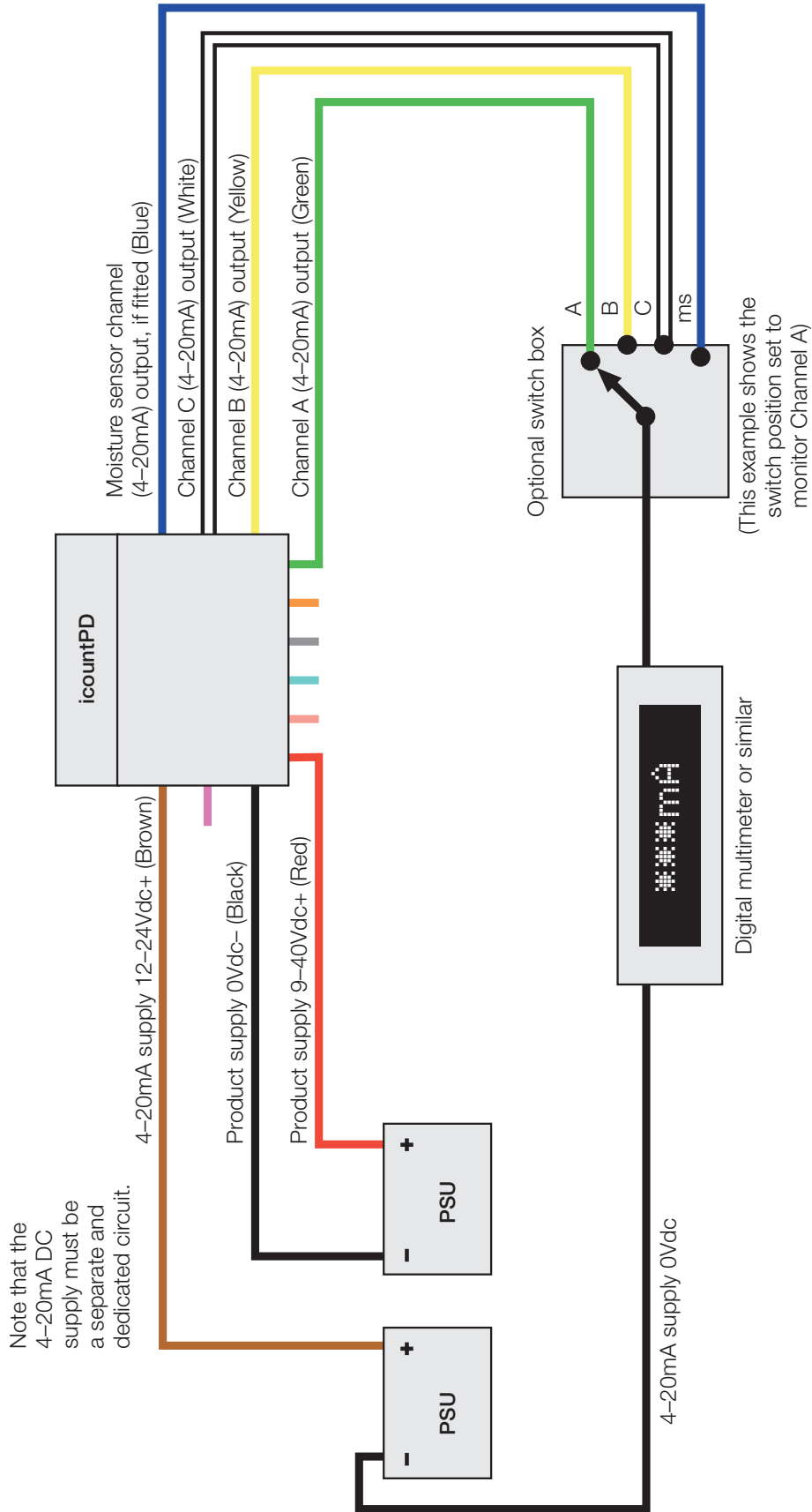

## M12 connector: Communication cable

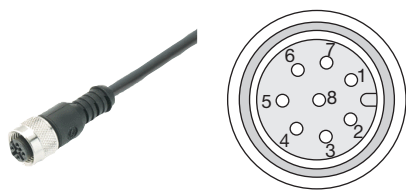

Pin configuration diagram  
M12 female connector, end view

Pin number (Wire colour recommended)	No options fitted	4–20mA option fitted	0–5V/0–3V option fitted	CAN option fitted
1 (White)	NOT USED	Channel C, ISO 14 $\mu$ m(c)	Channel C, ISO 14 $\mu$ m(c)	
2 (Brown)	RS232 Ground (* Pin 5)	RS232 Ground (* Pin 5)	RS232 Ground (* Pin 5)	RS232 Ground (* Pin 5)
3 (Green)	NOT USED	Channel A, ISO 4 $\mu$ m(c)	Channel A, ISO 4 $\mu$ m(c)	CAN (Hi)
4 (Yellow)	NOT USED	Channel B, ISO 6 $\mu$ m(c) or NAS (if selected)	Channel B, ISO 6 $\mu$ m(c) or NAS (if selected)	CAN (Lo)
5 (Grey)	RS232 Receive (* Pin 3)	RS232 Receive (* Pin 3)	RS232 Receive (* Pin 3)	RS232 Receive (* Pin 3)
6 (Pink)	RS232 Transmit (* Pin 2)	RS232 Transmit (* Pin 2)	RS232 Transmit (* Pin 2)	RS232 Transmit (* Pin 2)
7 (Blue)	NOT USED	Moisture sensor channel (if fitted)	Moisture sensor channel (if fitted)	CAN Ground
8 (Red)	NOT USED	NOT USED	NOT USED	

*NOTE: If the moisture sensor is fitted without the 4–20mA or the 0–5V/0–3V option, then the output is via RS232.*

*\* Parker Hannifin recommends the use of a 9-way D-type socket with RS232, using the pin configurations given in the above table.*

## M12 connector: Supply and Limit relay cable (if fitted)

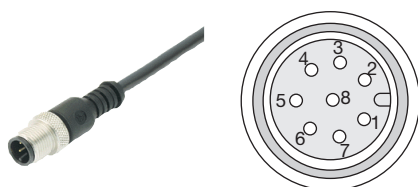

Pin configuration diagram  
M12 male connector, end view

Pin number (Wire colour recommended)	No options fitted	4–20mA option fitted	0–5V/0–3V option fitted
1 (White)	Relay Normally Closed (if fitted)	Relay Normally Closed (if fitted)	Relay Normally Closed (if fitted)
2 (Brown)	NOT USED	4–20mA Supply 12–20Vdc	0–5 / 0–3V Supply 12–24Vdc
3 (Green)	Relay Common (if fitted)	Relay Common (if fitted)	Relay Common (if fitted)
4 (Yellow)	Relay Normally Open (if fitted)	Relay Normally Open (if fitted)	Relay Normally Open (if fitted)
5 (Grey)	NOT USED	NOT USED	NOT USED
6 (Pink)	NOT USED	NOT USED	0–5V / 0–3V Supply 0 Vdc
7 (Blue)	Product supply 0Vdc	Product supply 0Vdc	Product supply 0Vdc
8 (Red)	Product supply 9–40Vdc	Product supply 9–40Vdc	Product supply 9–40Vdc

Parker Hannifin recommend that the mating M12 connector cables are screened. These cables are available from Parker Hannifin – see ‘Accessory part numbers’ on page 53 of this manual.

**IMPORTANT NOTE: It is the responsibility of the end user to ensure that the cable’s braided screen is terminated to a suitable earth bonding point.**



# M12 connector: Voltage measurement

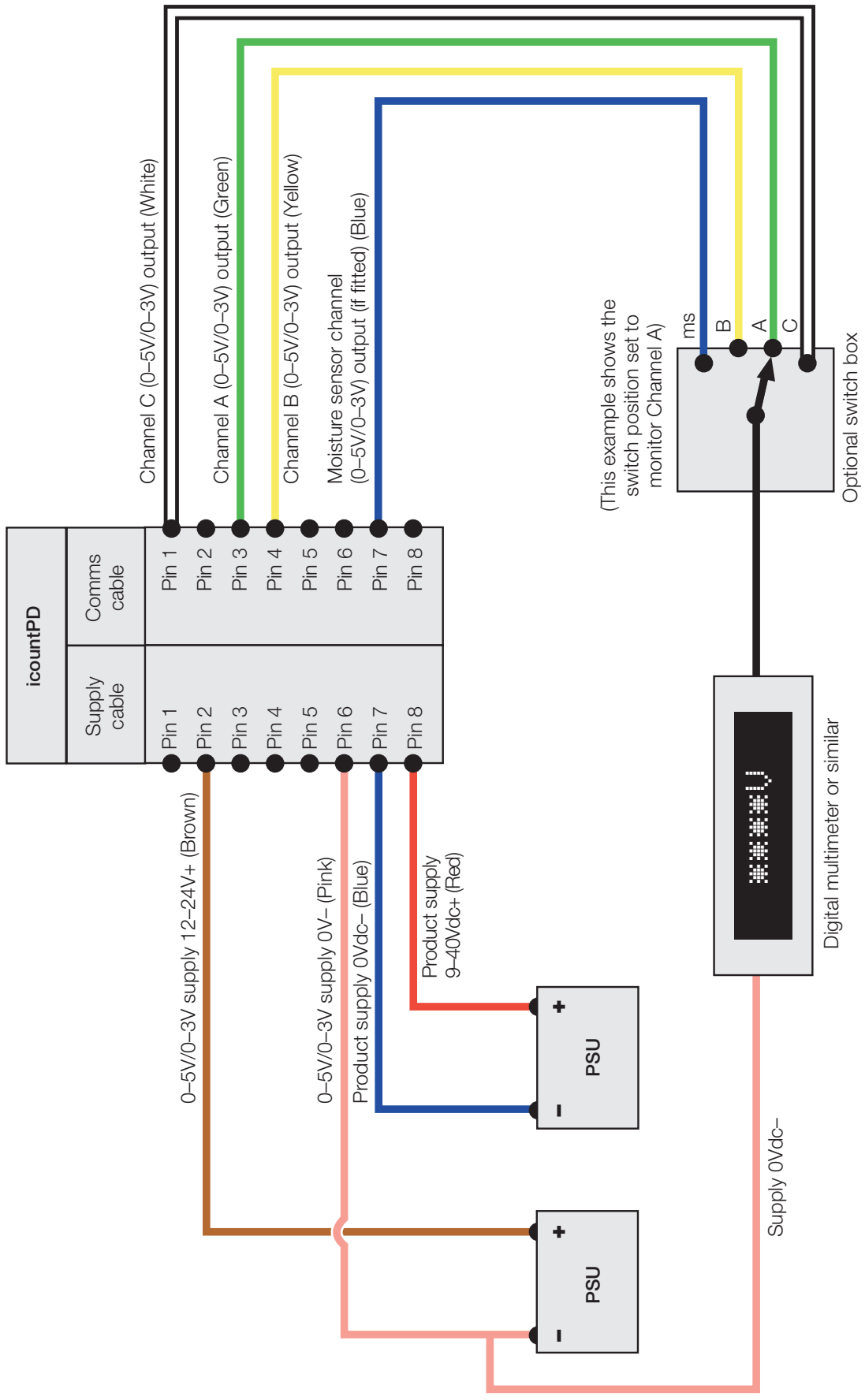

# M12 connector: Current measurement

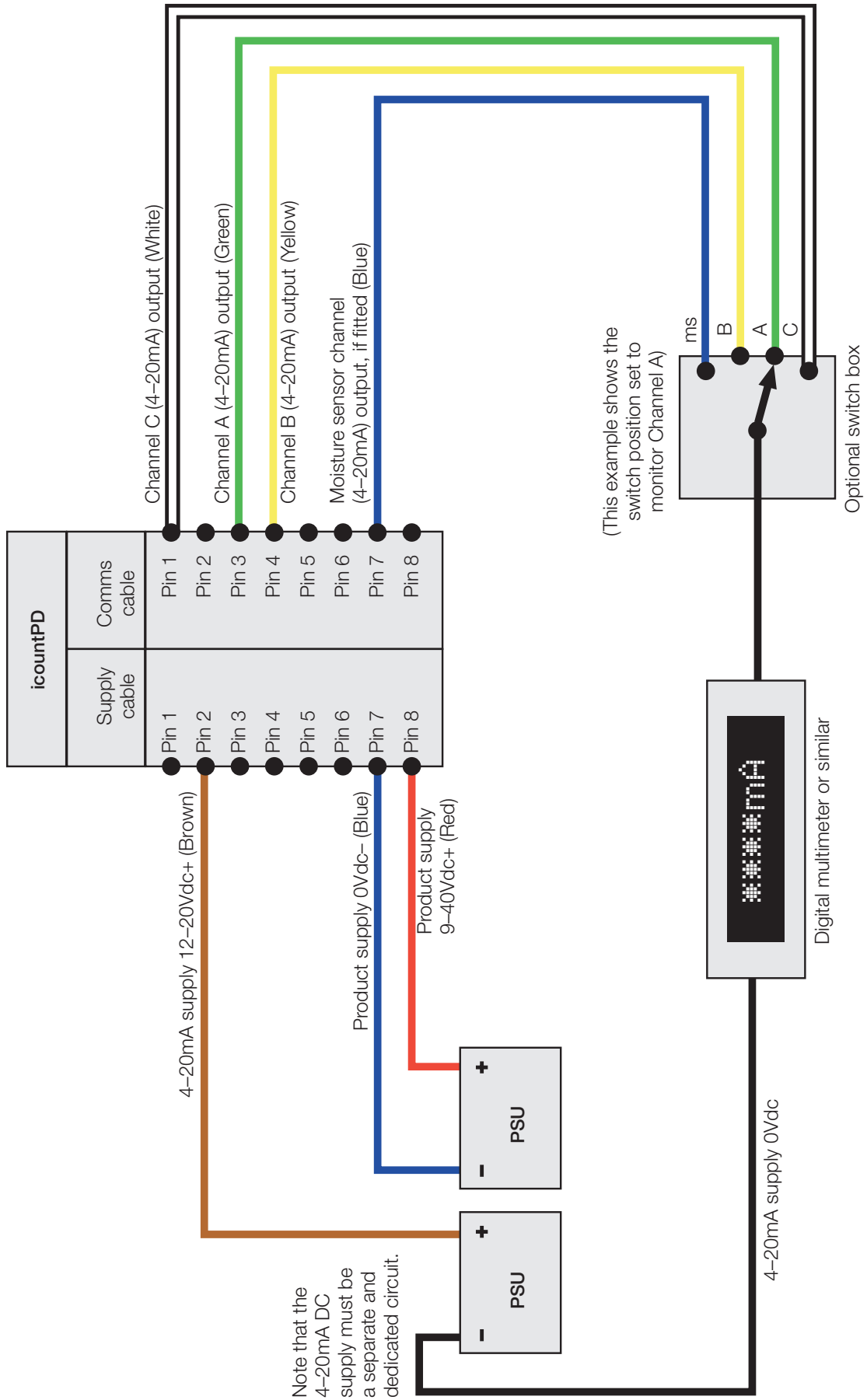

## Deutsch DT connector: Communication cable

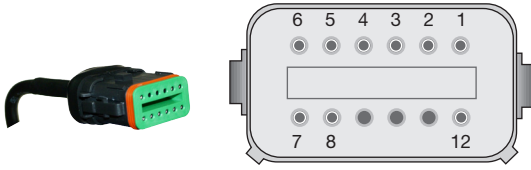

Pin configuration diagram  
Deutsch female connector, end view

Pin number	No options fitted	4–20mA option fitted	0–5V/0–3V option fitted	CAN option fitted
1	NOT USED	Channel C, ISO 14 $\mu$ m(c)	Channel C, ISO 14 $\mu$ m(c)	NOT USED
2	RS232 Ground (* Pin 5)	RS232 Ground (* Pin 5)	RS232 Ground (* Pin 5)	RS232 Ground (* Pin 5)
3	NOT USED	Channel A, ISO 4 $\mu$ m(c)	Channel A, ISO 4 $\mu$ m(c)	CAN+ (Hi)
4	NOT USED	Channel B, ISO 6 $\mu$ m(c) or NAS (if selected)	Channel B, ISO 6 $\mu$ m(c) or NAS (if selected)	CAN– (Lo)
5	RS232 Receive (* Pin 3)	RS232 Receive (* Pin 3)	RS232 Receive (* Pin 3)	RS232 Receive (* Pin 3)
6	RS232 Transmit (* Pin 2)	RS232 Transmit (* Pin 2)	RS232 Transmit (* Pin 2)	RS232 Transmit (* Pin 2)
7	NOT USED	Moisture sensor channel (if fitted)	Moisture sensor channel (if fitted)	CAN Ground
8	NOT USED	NOT USED	NOT USED	NOT USED
9	NOT USED	NOT USED	NOT USED	NOT USED
10	NOT USED	NOT USED	NOT USED	NOT USED
11	NOT USED	NOT USED	NOT USED	NOT USED
12	Screen termination	Screen termination	Screen termination	Screen termination

*NOTE: If the moisture sensor is fitted without the 4–20mA or the 0–5V/0–3V option, then the output is via RS232.*

*\* NOTE: Parker recommends the use of a 9-way D-type socket with RS232, using the pin configurations given in the above table.*

## Deutsch DT connector: Supply and Limit relay cable (if fitted)

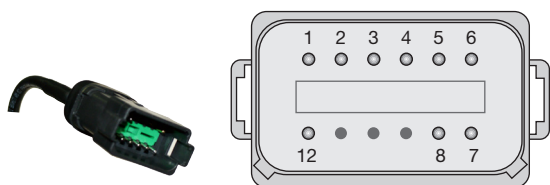

Pin configuration diagram  
Deutsch male connector, end view

Pin number	No options fitted	4–20mA option fitted	0–5V/0–3V option fitted	CAN option fitted
1	Relay Normally Closed (if fitted)	Relay Normally Closed (if fitted)	Relay Normally Closed (if fitted)	NOT USED
2	NOT USED	4–20mA Supply 12–20Vdc	0–5V / 0–3V Supply 12–24Vdc	NOT USED
3	Relay Common (if fitted)	Relay Common (if fitted)	Relay Common (if fitted)	NOT USED
4	Relay Normally Open (if fitted)	Relay Normally Open (if fitted)	Relay Normally Open (if fitted)	NOT USED
5	NOT USED	NOT USED	NOT USED	NOT USED
6	NOT USED	NOT USED	0–5V / 0–3V supply 0Vdc	NOT USED
7	Product supply 0Vdc	Product supply 0Vdc	Product supply 0Vdc	Product supply 0Vdc
8	Product supply 9–40Vdc	Product supply 9–40Vdc	Product supply 9–40Vdc	Product supply 9–40Vdc
9	NOT USED	NOT USED	NOT USED	NOT USED
10	NOT USED	NOT USED	NOT USED	NOT USED
11	NOT USED	NOT USED	NOT USED	NOT USED
12	Screen termination	Screen termination	Screen termination	NOT USED

Parker Hannifin recommend that the mating Deutsch connector cables are screened. These cables are available from Parker Hannifin – see the 'icountPD part number specifier' section in this manual.

**IMPORTANT NOTE: It is the responsibility of the end user to ensure that the cable's braided screen is terminated to a suitable earth bonding point.**

# Deutsch DT connector: Voltage measurement

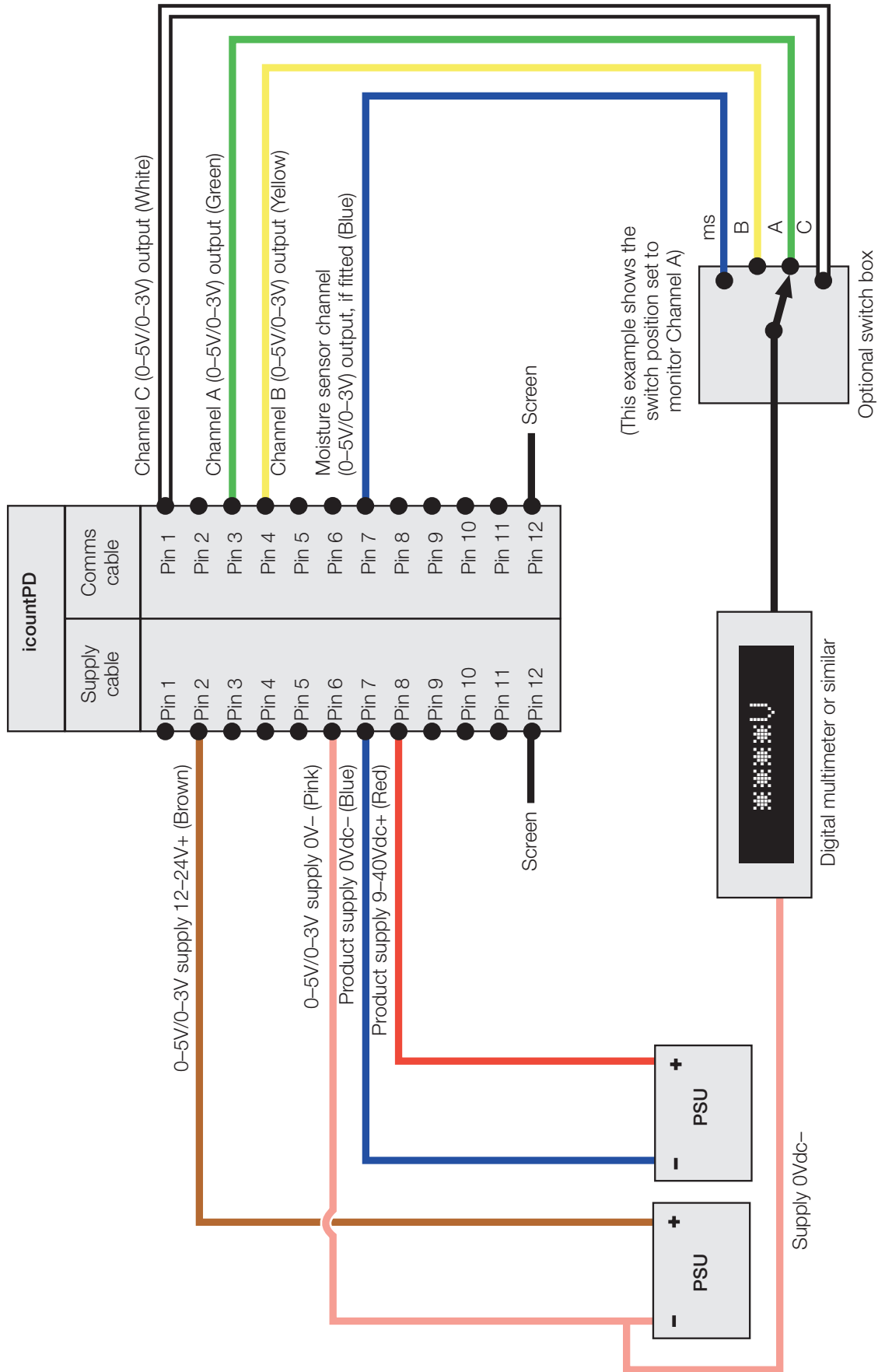

# Deutsch DT connector: Current measurement

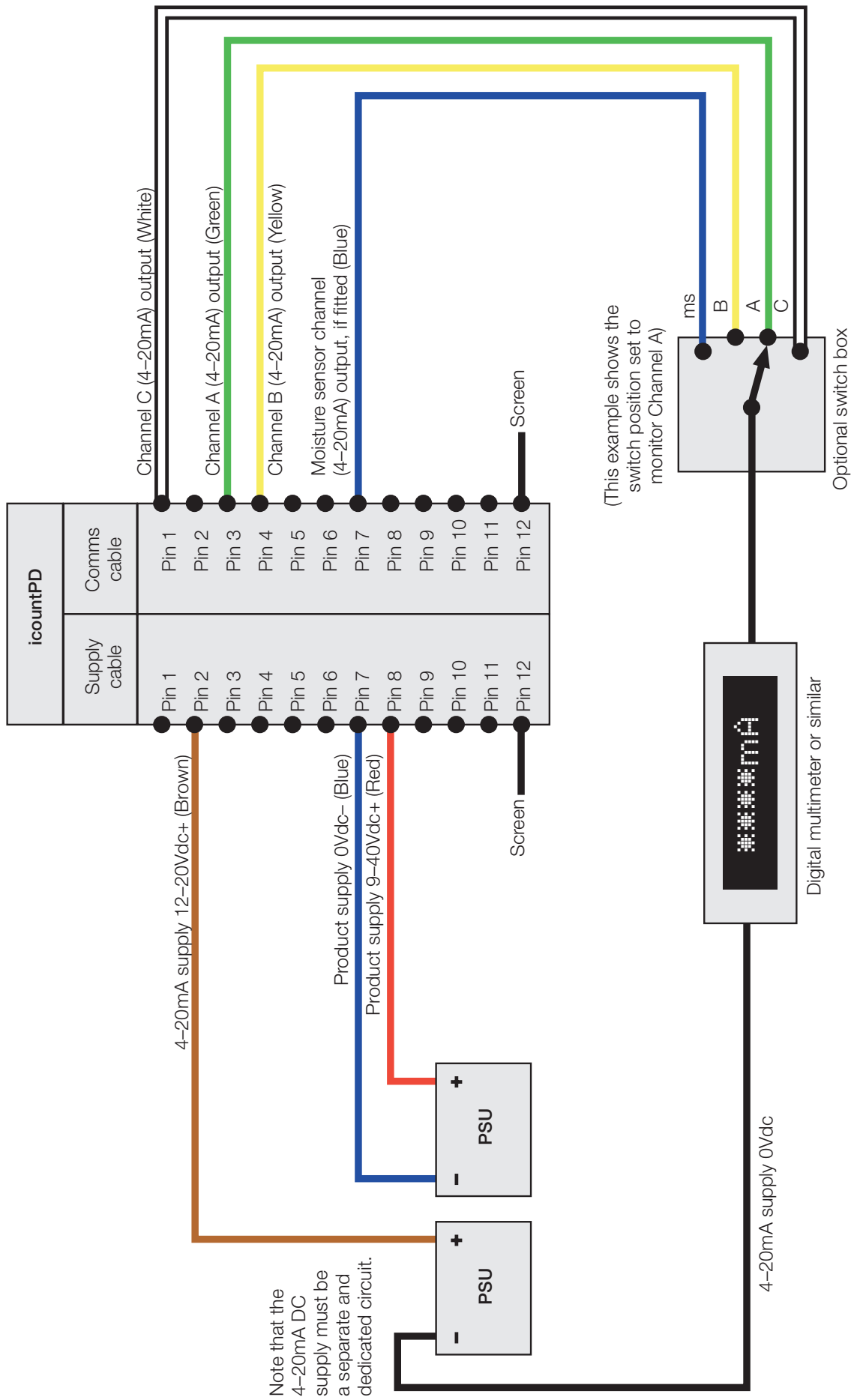

## Deutsch DT connector: CAN-bus (SAE J1939)

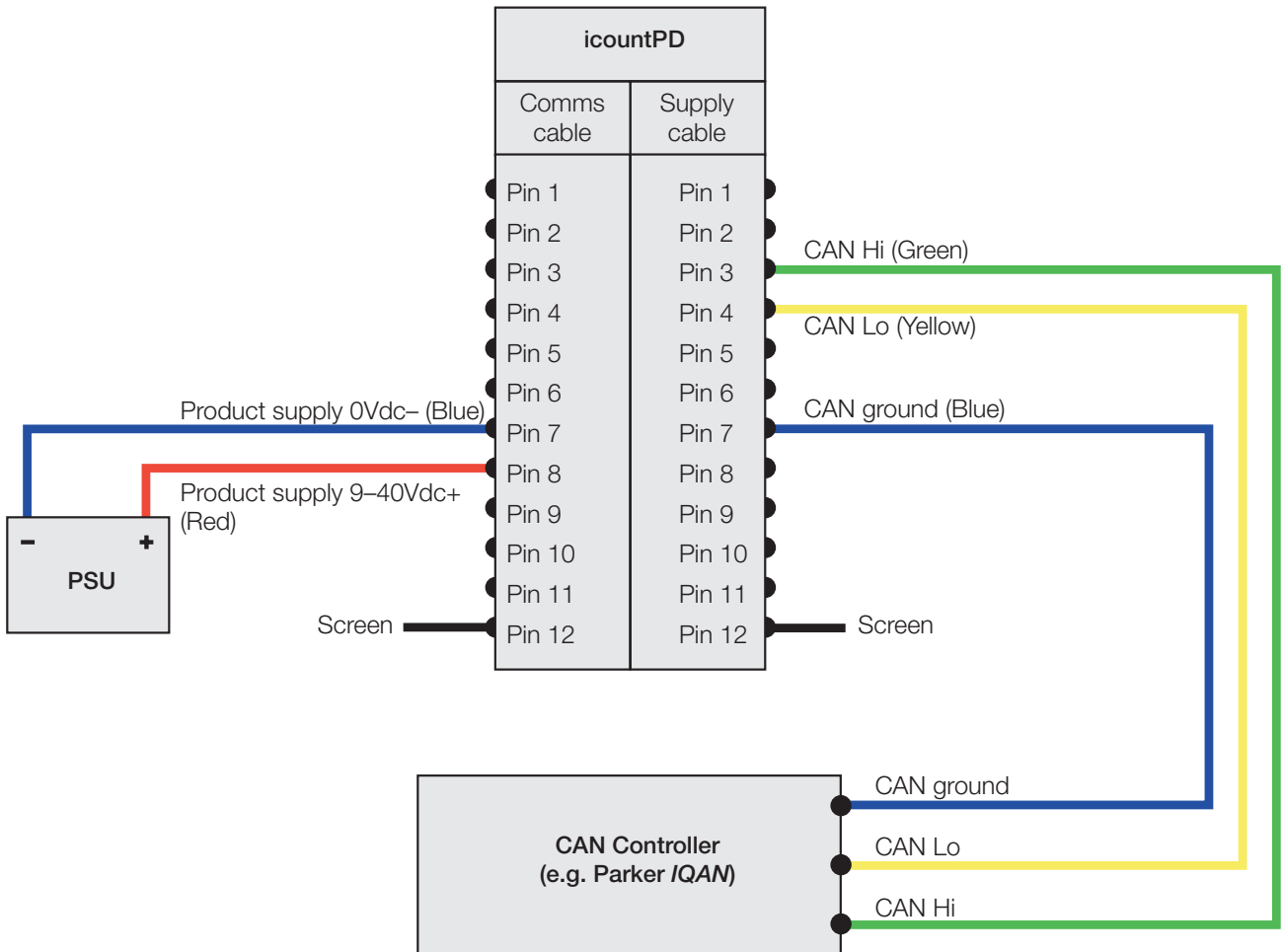

## Deutsch DT connector: contact assembly

### Step

- 1** Hold the crimped contact firmly, approximately 25mm (1 inch) behind the contact barrel.

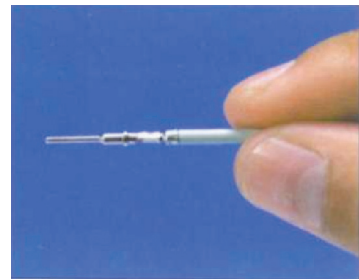

- 2** Present the connector with the rear grommet facing you.



- 3** Push the contact straight into the connector grommet until a click is felt. A slight tug confirms that it is locked into place correctly.

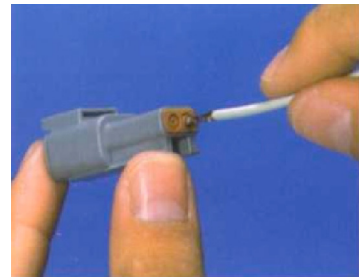

- 4** Once all contacts are in place, insert the orange wedge.  
Receptacles: with half-holes aligning with contacts. Plugs: with the contacts aligning behind full holes.  
The orange wedge snaps into place.  
(The receptacle is shown in this picture – use the same procedure for the plug.)





## Deutsch DT connector: contact removal

### Step

- 1 Remove the orange wedge using needlenose pliers to pull the wedge straight out.

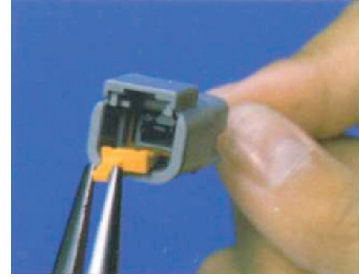

- 2 To remove the contacts, pull the wire back gently, at the same time releasing the locking finger by moving it away from the contact using a small screwdriver.

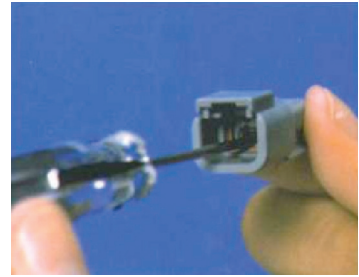

- 3 Hold the rear seal in place, because removing the contact will displace the seal.



# Variable current output settings

## ISO setting

The following table can be used to relate an analogue output (in mA) to an ISO code. For example, an output of 10mA is equal to an ISO code 12.

<b>mA</b>	4.0	4.5	5.0	5.5	6.0	6.5	7.0	7.5	8.0	8.5	9.0	9.5	10.0	10.5	11.0	11.5	12.0
<b>ISO</b>	0	1	2	3	4	5	6	7	8	9	10	11	12	13	14	15	16
cont. <b>mA</b>	12.5	13.0	13.5	14.0	14.5	15.0	15.5	16.0	16.5	17.0	17.5	18.0	18.5	19.0	19.5	20	
cont. <b>ISO</b>	17	18	19	20	21	22	*	*	*	*	*	*	*	Over-range	ERROR		

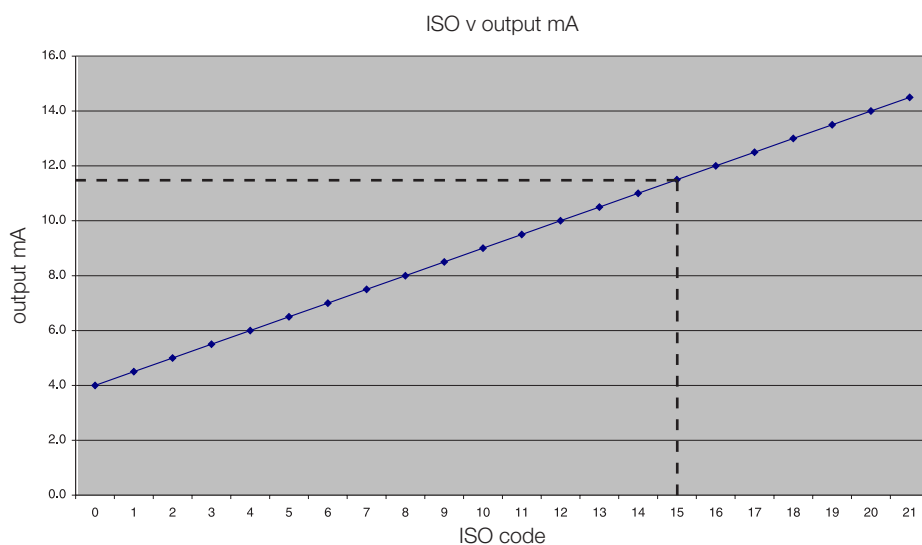

The actual calculation is as follows:  
 $ISO\ code = (output\ in\ mA - 4) \times 2$   
 e.g.  $(11.5mA - 4) \times 2 = 7.5 \times 2 = ISO\ 15$

\* = Saturation (i.e. above ISO code 22)

## NAS setting

The following table can be used to relate an analogue output (in mA) to a NAS code. For example, an output of 15mA is equal to NAS code 10.

<b>mA</b>	4	5	6	7	8	9	10	11	12	13	14	15	16	17	18	19	20
<b>NAS</b>	00	0	1	2	3	4	5	6	7	8	9	10	11	12	*	*	ERROR

Note: \* = Saturation (above NAS code 12)

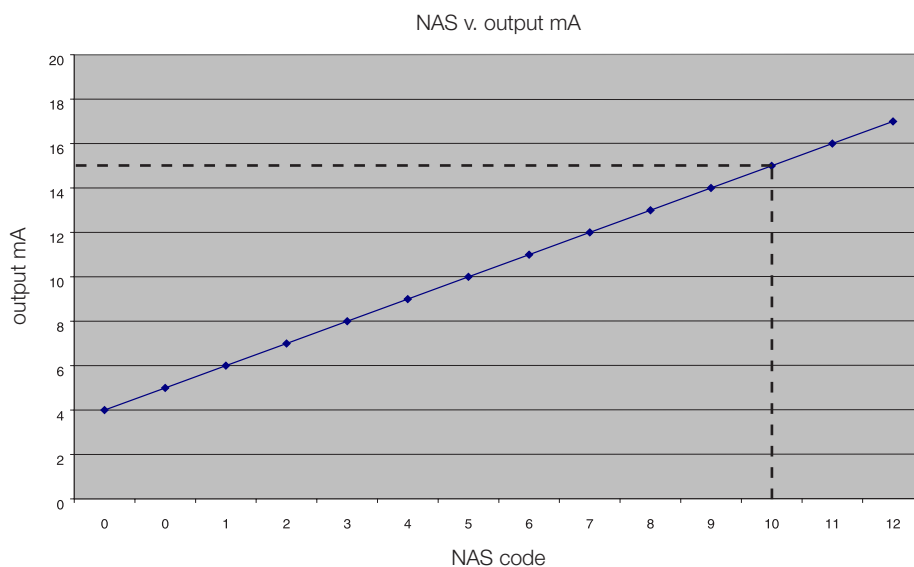

The actual calculation is as follows:  
 $NAS\ code = (output\ in\ mA - 5)$   
 e.g.  $15mA - 5 = NAS\ 10$

\* = Saturation (i.e. above NAS code 12)

## Variable voltage output settings

The variable voltage output option is capable of two different voltage ranges: a 0–5Vdc range as standard, and a user-selectable 0–3Vdc range. The ‘Full list of commands’ section of this manual (page 31-33) gives information on how to change the voltage output range.

The following tables can be used to relate the analogue output to an ISO or NAS code.

For example, in a 0–5Vdc range, ISO code 16 is equal to an output of 3.5Vdc. In a 0–3Vdc range, ISO code 8 is equal to an output of 1.0Vdc.

Table relating ISO codes to Voltage output

ISO	Err	0	1	2	3	4	5	6	7	8	9	10	11
0–5Vdc	<0.2	0.3	0.5	0.7	0.9	1.1	1.3	1.5	1.7	1.9	2.1	2.3	2.5
0–3Vdc	<0.15	0.2	0.3	0.4	0.5	0.6	0.7	0.8	0.9	1.0	1.1	1.2	1.3

cont	ISO	12	13	14	15	16	17	18	19	20	21	22	Err
	0–5Vdc	2.7	2.9	3.1	3.3	3.5	3.7	3.9	4.1	4.3	4.5	4.7	>4.8
	0–3Vdc	1.4	1.5	1.6	1.7	1.8	1.9	2.0	2.1	2.2	2.3	2.4	>2.45

Table relating NAS codes to Voltage output

NAS	Err	00	0	1	2	3	4	5	6	7	8	9	10	11	12	Err
0–5Vdc	<0.4	0.6	0.9	1.2	1.5	1.8	2.1	2.4	2.7	3.0	3.3	3.6	3.9	4.2	4.5	>4.6
0–3Vdc	<0.2	N.S.	0.3	0.5	0.7	0.9	1.1	1.3	1.5	1.7	1.9	2.1	2.3	2.5	2.7	>2.8

(N.S. = Not Supported)

## CAN-bus network output option

If you plan to use the icountPD with a CAN-bus (SAE J1939) network, you can order this output option when specifying the icountPD. Refer to the ‘Product configurator’ (page 53) in the Reference section of this manual. The CAN option provides an interface to external CAN-bus networked systems (for example, to the *Parker IQAN*).

## Moisture sensor output settings

The Moisture sensor is an option that can be included when specifying the icountPD. Refer to the ‘Product configurator’ (page 53) in the Reference section of this manual.

The Moisture sensor reports on the saturation levels of the fluid passing through the icountPD sensing cell. The output is a linear scale, reporting within the range of 5% saturation to 100% saturation.

TABLE RELATING SATURATION LEVELS IN THE SENSING CELL TO ICOUNTPD OUTPUTS

Saturation	4–20mA	0–3Vdc	0–5Vdc
5%	4.8	0.15	0.25
25%	8	0.75	1.25
50%	12	1.50	2.50
75%	16	2.25	3.75
100%	20	3.00	5.00

## RS232 connectivity

Communication can be established between icountPD and a PC using an RS232 serial connection with the **Parker Utility Setup Tool**, the **Parker Terminal** utility, or via Microsoft Windows® **HyperTerminal**.

Please note that **HyperTerminal** is not supplied with Windows Vista™, but the **Parker Utility Setup Tool** and **Parker Terminal** can be used with this operating system. Both Parker programs are supplied on the icountPD CD.

### PC connection

The RS232 wires need to be connected to a 9-way D-type connector (not supplied as standard). For the connector pin termination and wire colour, refer to the 'Communication cable wiring configuration' section of this manual (page 12).

The device can then be either connected direct to PC serial port (Figure 1) or connected via an RS232-to-USB adaptor cable (Figure 2).

An RS232 to USB convertor can be supplied by Parker Hannifin (part number B84011).

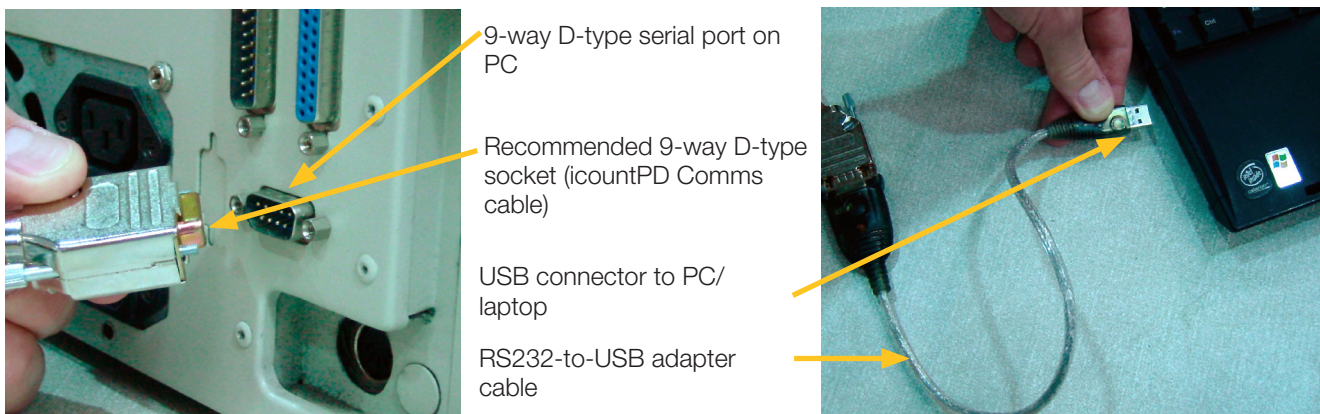

Figure 1

Figure 2

---

*Note: The 9-way D-type connector, RS232-to-USB adaptor cable and installation software are not supplied as standard with the icountPD.*

---

# Software

The icountPD may be configured using the **icountPD Setup Utility**, supplied on CD.

For more direct control of the device using its communications protocol, you may use the **Parker Terminal** program: both Parker programs are supplied on the icountPD CD. You may also use Microsoft Windows® **HyperTerminal** program, but note that this program is not currently supplied with the Windows Vista™ operating system.

## icountPD Setup Utility software

### PC Installation

The icountPD Setup Utility and Parker Terminal software is available on the CD supplied with the icountPD. The software can be run directly from the CD or copied to a PC hard drive.

### Using the icountPD Setup Utility

Check that the icountPD is connected to power and the communication cable is connected to the PC via the RS232 plug.

Place the CD in your PC drive and wait for the selection screen to appear. On starting the software, the icountPD Setup Utility screen appears.

#### Step 1A:

With the icountPD connected to power and the RS232 connected to the PC, select the appropriate communication port.

#### Step 1B:

Note the status of the icountPD.

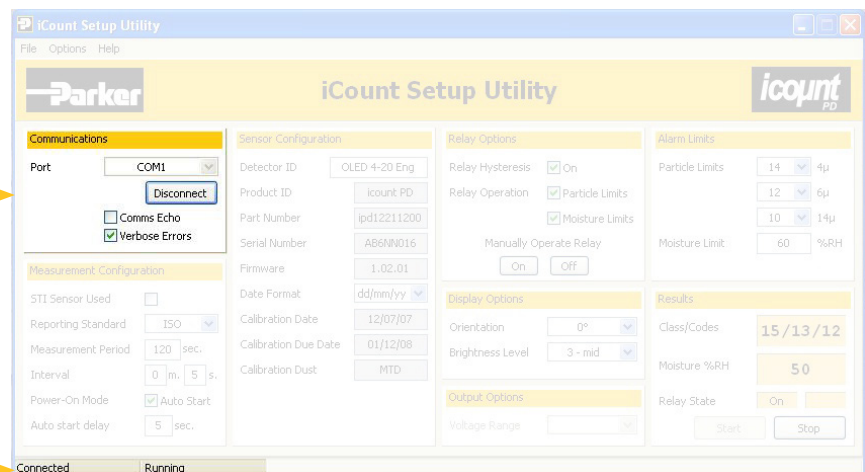

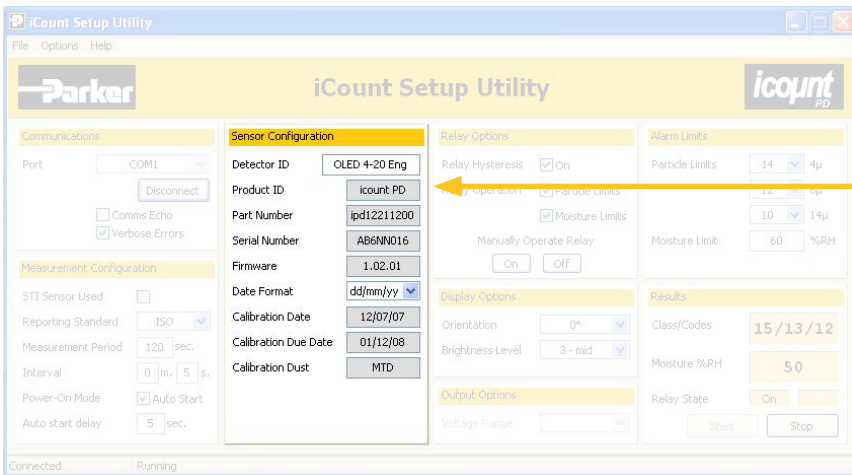

**Step 2:**

Set the values for 'Detector ID' and 'Date Format'.

The remaining detector information is preset by Parker Hannifin and cannot be changed.

**Step 3:**

Set the values in 'Measurement Configuration', 'Relay Options' and 'Alarm Limits'.

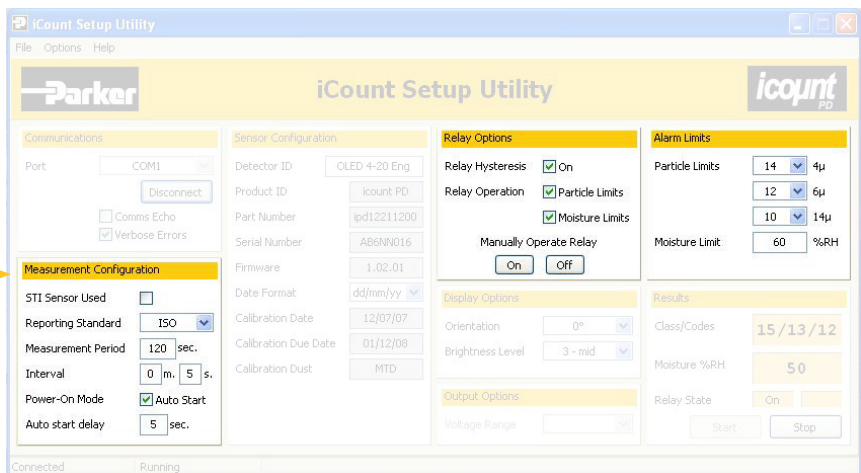

**Step 4:**

Set the values for Orientation and Brightness Level in 'Display Options' and Voltage Range (0-5V, 0-3V or J1939) in 'Output Options' if either of these options are fitted.

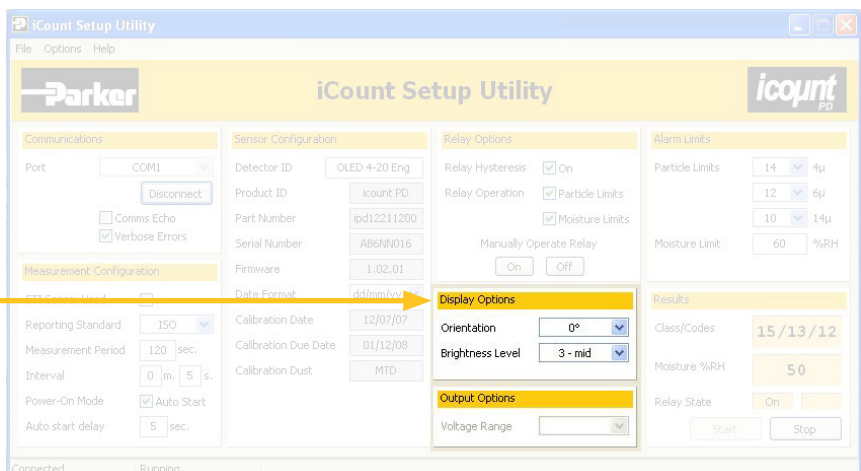

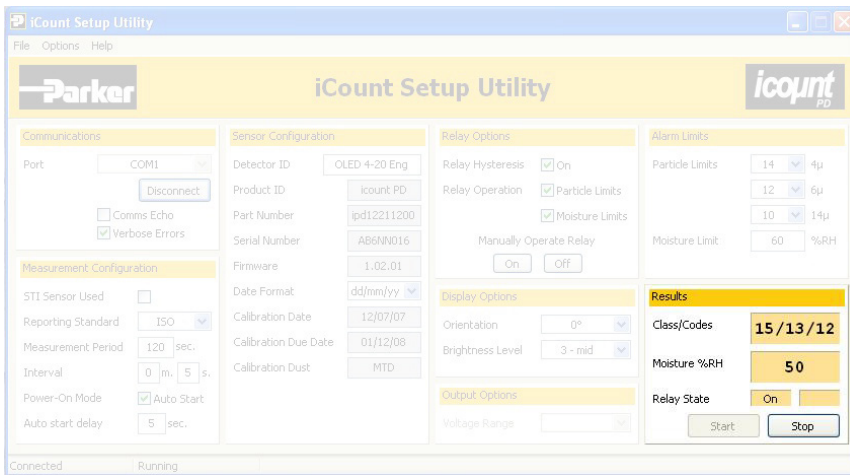

**Step 5:**

Setup values are verified as valid in 'Results'.

Click 'Start' to start verification and 'Stop' to stop.

# Microsoft Windows® HyperTerminal connection

An alternative way of achieving communication with icountPD is to use the HyperTerminal program supplied with Microsoft Windows (but not always installed on the PC or laptop's hard disk – check the installation disk, or contact your organisation's IT department if the program is not present).

**Please note that HyperTerminal is not supplied with Windows Vista™, but the Parker Terminal utility can be used with this operating system.**

The standard communication settings (used in STEP 4) are as follows:

Baud Rate	9600
Data bits	8
Parity	None
Stop bits	1
Flowcontrol	None



## Step 1:

Click 'Start'

## Step 2:

Select 'HyperTerminal'.

(from All Programs  
 ▶ Accessories  
 ▶ Communications  
 ▶ HyperTerminal)

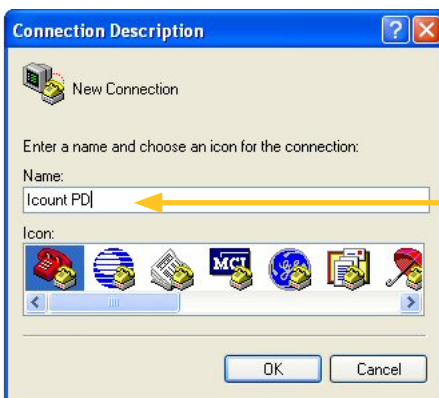
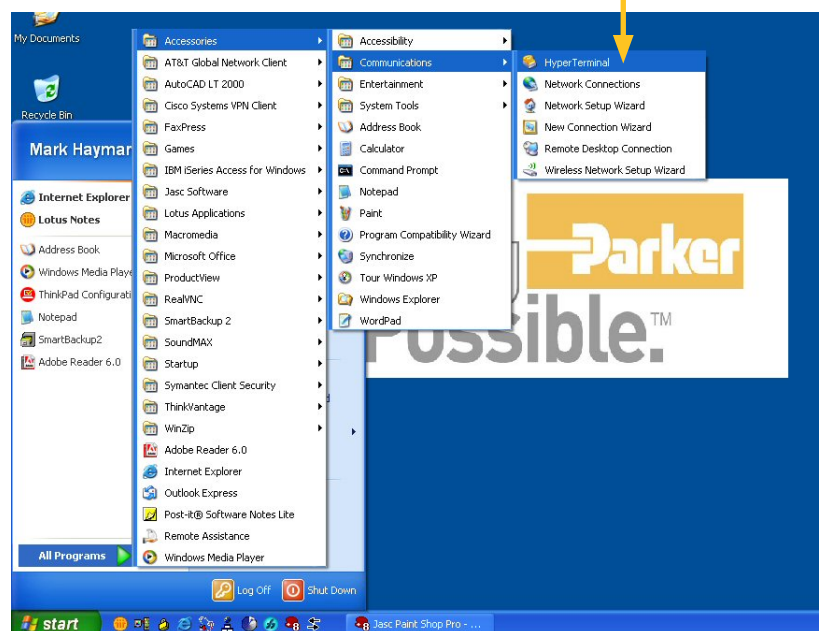

## Step 3:

Click and type the connection name you wish to use to identify this session





**Step 4:**  
Select the appropriate USB port.

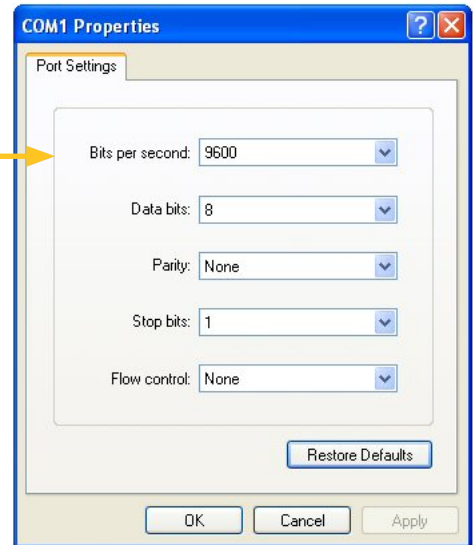

**Step 5:**  
Enter the communication settings (as in the 'standard communications settings' table, on the previous page).

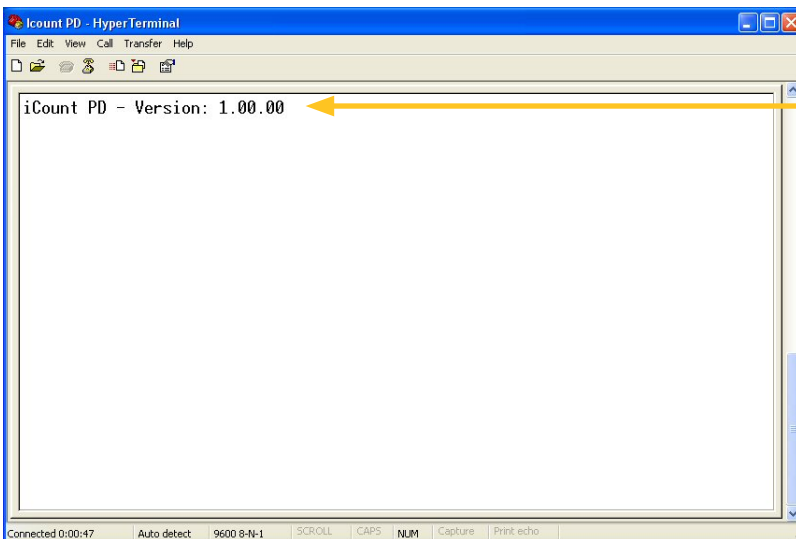

**Step 6:**  
Once the iCountPD is connected to power, the product identification is displayed. This identifies successful communication to iCountPD. The iCountPD is now ready for operation.

## Communication protocol

The commands used with the icountPD are either made up of Read, Set or Start/Stop commands.

**Read** commands allow the value or values of parameters to be read

**Set** commands allow the value or values of parameters to be changed

**Start/Stop** commands allow the user to start and stop tests.

### Example:

[SDF dd/mm/yy] sets the date format

[RDF] reads the product format date

All commands are sent in ASCII characters, and the protocol accepts both upper and lower case characters. For example, all of the following codes are equivalent:

SDF = Sdf = SDF = sdf = sdf

---

*NOTE: The use of a '=' after a command, for example [SDF = dd/mm/yy], is optional.*

---

Certain commands are for internal use only and can be accessed via a password system. Should an unauthorized person attempt to access these commands the icountPD returns an error code for 'Invalid Command'.

## Most-used commands

Common User Read commands		
Command	Description	icountPD response
RDU	Read calibration dust	Calibration dust displayed (i.e. MTD or ACFTD)
RLT	Read NAS or ISO limits	Limits displayed
RRS	Read reporting standard	ISO or NAS displayed

Common User Set commands		
Command	Description	User response
SLT	Set limits i.e. 'SLT 19 18 15'	SLT ## ## ## (for ISO) SLT ## (for NAS)
SRS	Set reporting standard	SRS iso SRS nas
SRI	Set reporting interval 0 to 3600 seconds 0 = No reporting	SRI #####

---

*NOTE: The reporting interval (SRI) controls how often the icountPD sends results over the RS232.*

---

User Start/Stop commands		
Command	Description	Response
STR or START	Start testing	'OK' displayed
STP or STOP	Stop testing	'OK' displayed

## Full list of commands

User Read Commands		
Command	Description	icountPD response
RCD	Read the last <b>C</b> alibration <b>D</b> ate	Last calibration date displayed
RCE	Read <b>C</b> ommunication <b>E</b> cho	'ON' or 'OFF' displayed
	Comms Echo ON allows the icountPD to communicate in two directions (Hyperterminal) Comms Echo OFF allows the icountPD to communicate in one direction (Setup Utility)	
RDB	Read <b>D</b> isplay <b>B</b> rightness	Brightness levels 1–5
RDD	Read the next calibration <b>D</b> ue <b>D</b> ate	Next calibration due date displayed
RDF	Read <b>D</b> ate <b>F</b> ormat	Date format displayed (i.e. dd/mm/yy)
RDI	Read <b>D</b> etector <b>I</b> D	Detector ID displayed
RDO	Read Digital <b>D</b> isplay <b>O</b> rientation <sup>4</sup>	RDO=0 Normal (0°), RDO=1 90° RDO=2 180°, RDO=3 270°
RDS	Read <b>D</b> etector <b>S</b> tatus	IPD status displayed (i.e. RUNNING)
RDU	Read the calibration <b>D</b> ust <b>U</b> nit	Calibration dust displayed (i.e. MTD or ACFTD)
REN	Read last <b>E</b> rror <b>N</b> umber	Last error number displayed
RER	Read last <b>E</b> rror text <b>R</b> eport	Last error text displayed
REV	Read the <b>E</b> rror <b>V</b> erbose mode	Error verbose mode displayed
	<i>Error Verbose ON displays the full description of the error code (i.e. Error 40 - expected On or Off)</i> <i>Error Verbose OFF displays just the error code (i.e. Error 40)</i>	
RFN	Read <b>F</b> ault <b>N</b> umber	Fault number displayed
RJE	Read <b>J</b> 1939 Status	'ON' or 'OFF' displayed
RLR	Read the <b>L</b> ast contamination <b>R</b> esult	Last contamination result displayed
RLT	Read contamination <b>L</b> imit <b>T</b> hreshold	Contamination limits displayed
RML	Read <b>M</b> oisture sensor <b>L</b> imit <sup>1</sup>	Moisture limit displayed
RMP	Read <b>M</b> easurement <b>P</b> eriod	Measurement period displayed
RMV	Read the last <b>M</b> oisture sensor <b>V</b> alue <sup>1</sup>	Last moisture result displayed
ROF	Read <b>O</b> ptions <b>F</b> itted	ROF = ABCDEFGHIJ (see list of options below)
RON	Read <b>O</b> ption <b>N</b> ame	List of options A = Alarm relay option B = LED display option C = OLED display option D = Moisture sensor option E = 4–20mA current loop option F = 0–3/0–5V option G = J1939 option H = reserved I = reserved J = reserved
RPD	Read the <b>P</b> ower on hold-off <b>D</b> elay	Power hold-off delay displayed
RPI	Read <b>P</b> roduct <b>I</b> dentifier	icountPD displayed
RPM	Read the <b>P</b> ower on <b>M</b> ode	'AUTO' or 'MANUAL' displayed
RPN	Read the icountPD <b>P</b> art <b>N</b> umber	Parker part number displayed
RPT	Read <b>P</b> roduct <b>T</b> ype	IPDH
RPV	Read <b>P</b> rotocol <b>V</b> ersion	Protocol version displayed
RRI	Read <b>R</b> eporting <b>I</b> nterval	Reporting interval displayed
RRS	Read <b>R</b> eporting <b>S</b> tandard	'ISO' or 'NAS' displayed

<b>RSB</b>	<b>Read Software Build number</b>	Software build number displayed
<b>RSH</b>	<b>Read limit relay Switch Hysteresis</b> <sup>2</sup>	'ON' or 'OFF' displayed
<b>RSL</b>	<b>Read Standards List</b>	ISO, NAS
<b>RSN</b>	<b>Read Serial Number</b>	Serial number displayed
<b>RSS</b>	<b>Read limit relay Switch State</b> <sup>2</sup>	'ON' or 'OFF' displayed
<b>RSU</b>	<b>Read STI Sensor Used</b>	'YES' or 'NO' displayed
<b>RSV</b>	<b>Read Software Version displayed</b>	Software version displayed
<b>RVM</b>	<b>Read the Voltage Maximum range</b> <sup>3</sup>	Voltage range displayed
<b>RWC</b>	<b>Read Warning limit relay for Contamination</b> <sup>2</sup>	'ON' or 'OFF' displayed
<b>RWM</b>	<b>Read Warning limit relay for Moisture</b> <sup>1,2</sup>	'ON' or 'OFF' displayed

<sup>1</sup> Command requires a Moisture Sensor to be fitted to icountPD

<sup>2</sup> Command requires a Limit Relay to be fitted to icountPD

<sup>3</sup> Command requires a 0–5V option to be fitted to icountPD

<sup>4</sup> Command requires digital display option to be fitted to icountPD

<b>User Set Commands</b>		
<b>Command</b>	<b>Description</b>	<b>icountPD response</b>
<b>SCE</b>	<b>Set Communication Echo</b>	SCE on SCE off
	<i>Comms Echo ON allows icountPD to communicate in two directions (Hyperterminal) Comms Echo OFF allows icountPD to communicate in one direction (Setup Utility)</i>	
<b>SDB</b>	<b>Set Display Brightness</b>	Set levels 1–5
<b>SDF</b>	<b>Set Date Format</b>	SDF dd/mm/yy SDF mm/dd/yy SDF yy/mm/dd
<b>SDI</b>	<b>Set Detector ID</b>	SDI ##### (14 characters maximum, spaces not allowed)
<b>SDO</b>	<b>Set Digital Display Orientation</b> <sup>4</sup>	SDO=0 Normal (0°), SDO=1 90° SDO=2 180°, SDO=3 270°
<b>SEV</b>	<b>Set the Error Verbose mode</b>	SEV on SEV off
	<i>Error Verbose ON displays the full description of the error code (i.e. Error 40 - Expected On or Off) Error Verbose OFF displays just the error code (i.e. Error 40)</i>	
<b>SJE</b>	<b>Set J1939 Status</b>	SJE On/Off (can only set On)
<b>SLT</b>	<b>Set contamination Limit Threshold</b>	SLT ## # # (for ISO) SLT ## (for NAS)
<b>SML</b>	<b>Set Moisture sensor Limit</b> <sup>1</sup>	SML ###
<b>SMP</b>	<b>Set Measurement Period</b>	SMP ### (### = 5 to 180 seconds)
	<i>The Measurement period sets the number of seconds the detector uses to determine the contamination levels. So if this is 60 seconds, the unit will use the last 60 seconds of oil to determine the contamination level. (See the 'Component cleanliness guideline' chart in the Reference section of this manual.)</i>	
<b>SPD</b>	<b>Set the Power on hold-off Delay</b>	SPD ### (### = 5 to 900 seconds)
	<i>The Power-on hold-off delay command allows the user to delay the start of the icountPD operation.</i>	
<b>SPM</b>	<b>Set the Power on Mode</b>	SPM auto SPM manual

With the Power-on Mode set to 'Auto' icountPD starts testing automatically when the power is connected using the last setup parameters. With the Power-on Mode set to 'Manual' icountPD becomes idle and requires the user to manually start testing.

<b>SRI</b>	<b>Set Reporting Interval</b>	SRI mm:ss (0 to 3600 seconds (i.e. 0–1 hour); note that 0 = No reporting)
<i>The Reporting Interval controls how often icountPD sends results over the RS232</i>		
<b>SRS</b>	<b>Set Reporting Standard</b>	SRS iso SRS nas
<b>SSH</b>	<b>Set limit relay Switch Hysteresis</b> <sup>2</sup>	SSH on SSH off
<b>SSS</b>	<b>Set limit relay Switch State</b> <sup>2</sup>	SSS on SSS off
<b>SSU</b>	<b>Set STI Sensor Used</b>	SSU yes SSU no
<b>SVM</b>	<b>Set the Voltage Maximum range</b> <sup>3</sup>	SVM # (3 = 0–3Vdc output 5 = 0–5Vdc output)
<b>SWC</b>	<b>Set Warning limit relay for Contamination</b> <sub>2, 5</sub>	SWC on SWC off
<b>SWM</b>	<b>Set Warning limit relay for Moisture</b> <sup>1, 2, 5</sup>	SWM on SWM off

<sup>1</sup> Command requires a Moisture sensor to be fitted to the icountPD

<sup>2</sup> Command requires a Limit Relay to be fitted to the icountPD

<sup>3</sup> Command requires a 0–5Vdc option to be fitted to the icountPD

<sup>4</sup> Command requires digital display option to be fitted to icountPD

<sup>5</sup> If the Limit Relay has been turned OFF for both Contamination monitoring and Moisture sensing, the Limit Relay will not operate, but the alarm status is not affected.

If the Limit Relay has been turned ON for both Contamination monitoring and Moisture sensing, the Limit Relay will operate when any alarm condition is reached.

# Front panel displays

## LED display parameters (ISO4406 / NAS1638)

### Start up

1. Once the icountPD has been connected to a regulated power supply, all four LEDs will roll from top to bottom for a minimum of five seconds as the icountPD performs a system diagnostic check.
2. The icountPD then automatically starts monitoring using the factory default test parameters. Only if the Power on Mode is set to Auto (product default).

### LED indication

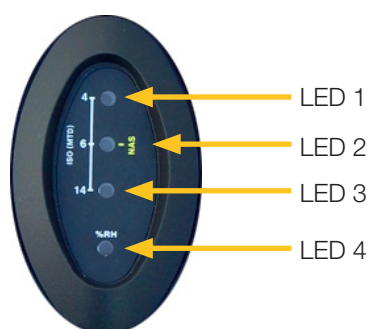

The icountPD uses LED 1, 2 and 3 for the indication of ISO 4406; LED 2 alone is used for the NAS1638 code. Individual code lights trigger according to user settings. The order of triggering is:

<b>Solid green</b>	trips at all codes below the set point (limit) code
<b>Flashing green</b>	LED trips at the set point code
<b>Solid red</b>	LED trips at the set point plus 1 code
<b>Flashing red</b>	LED trips at the set point plus 2 codes

LED 4 is reserved for the icountPD Moisture Sensor. Contact Parker Hannifin for details of its specification.

#### ISO EXAMPLE

Assuming the limits on the icountPD have been set to 18/16/12 and the actual particles detected by the icountPD is giving a ISO result of 20/17/11.

<b>LED 1</b>	<b>flashes red</b> , 2 codes higher than the set limit
<b>LED 2</b>	appears <b>solid red</b> (1 code higher),
<b>LED 3</b>	appears <b>solid green</b> (1 code lower)

#### NAS EXAMPLE:

Assuming that the limit on the icountPD has been set to 7 and the actual particles detected by the icountPD is giving a NAS result of 9.

<b>LED 2</b>	<b>flashes red</b> (2 codes higher)
--------------	-------------------------------------

#### LED MOISTURE SENSOR INDICATOR (LED 4):

<b>LED 4</b>	<b>Solid green</b> trips at %RH (percentage Relative Humidity) level or below the set point (limit)
<b>LED 4</b>	<b>Solid red</b> trips above the %RH level

## Error detection

Errors which can be easily corrected are indicated by a **short flashing amber** LED.

LED 1	LED 2	
On	Off	Fault 1 – Laser too hot – Oil is too hot. Allow to cool
Off	On	Fault 2 – Light level is bad – Flush with clean oil and retry

Errors that require the unit to be returned to the supplier or service centre are indicated by a **double flashing amber** LED.

LED 1	LED 2	
On	Off	Fault 1 – Channel failure – Impossible Count Readings

## Digital display parameters (ISO 4406 / NAS 1638)

### Start up

1. Once the icountPD has been connected to a regulated power supply, the product logo is displayed for approximately five seconds as the icountPD performs a system diagnostic check.
2. If the Power-on mode is set to Auto – the factory default – the icountPD automatically starts monitoring, using the default test parameters.

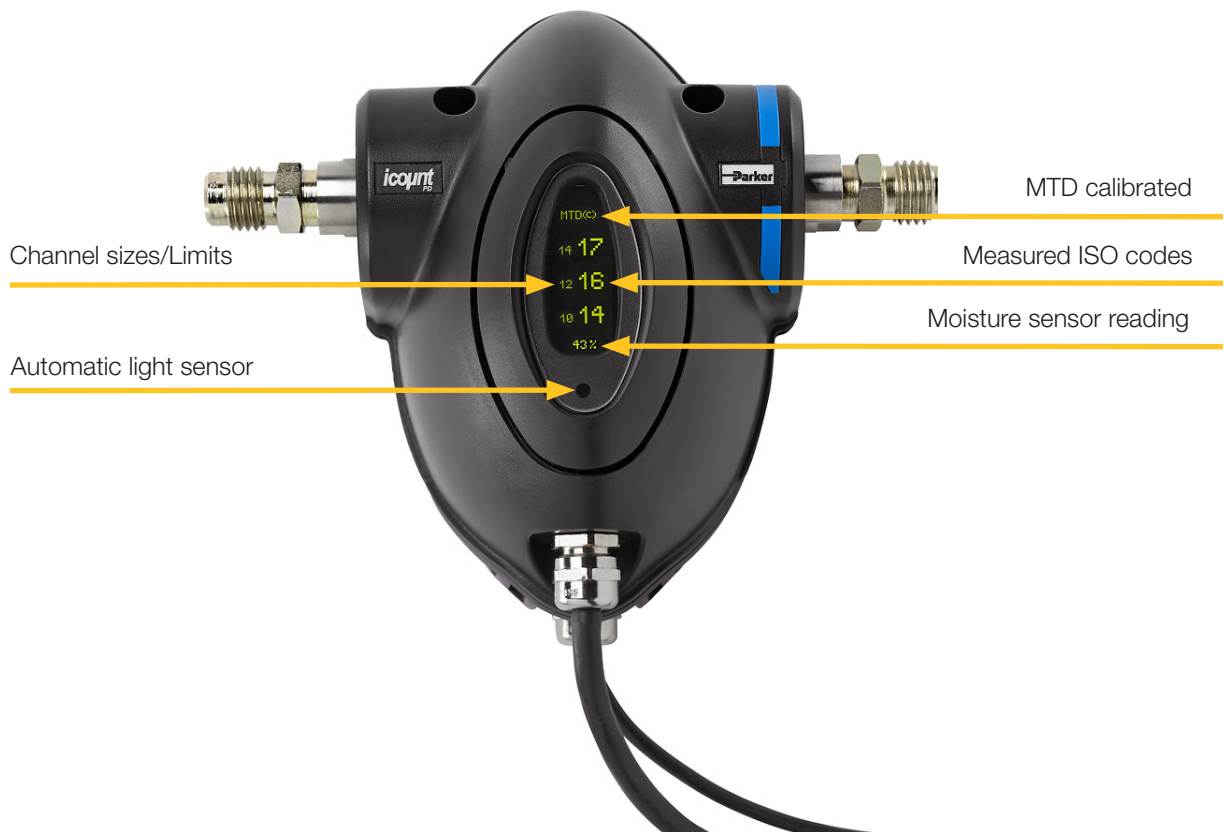

## Digital display indication

The digital display shows the actual measured codes, the size per channel (in microns) and the user definable limits. Note that the channel size and the limits are displayed alternately.

If the Moisture Sensor option is fitted, the Moisture Sensor reading (%RH) is also shown.

The order of trigger for both ISO, NAS and Moisture Sensor option is:

- Solid digit(s) – code(s) that are at or below the set point (limit).
- Flashing digit(s) – code(s) that are above the set point (limit).

## Automatic Light Sensor

The digital display on the icountPD is fitted with an automatic light sensor. This automatically adjusts the brightness of the display for optimal reading, depending on the actual light conditions where the product is located.

The icountPD brightness level default is 3. The brightness levels range from 1 (low) to 5 (high), 3 being the mid-point.

## Display Orientation

The digital display can be orientated using the icountPD Setup Utility software to suit the way in which the unit has been fitted. The default display orientation is 0°; the other settings are 90°, 180°, and 270° clockwise from default.

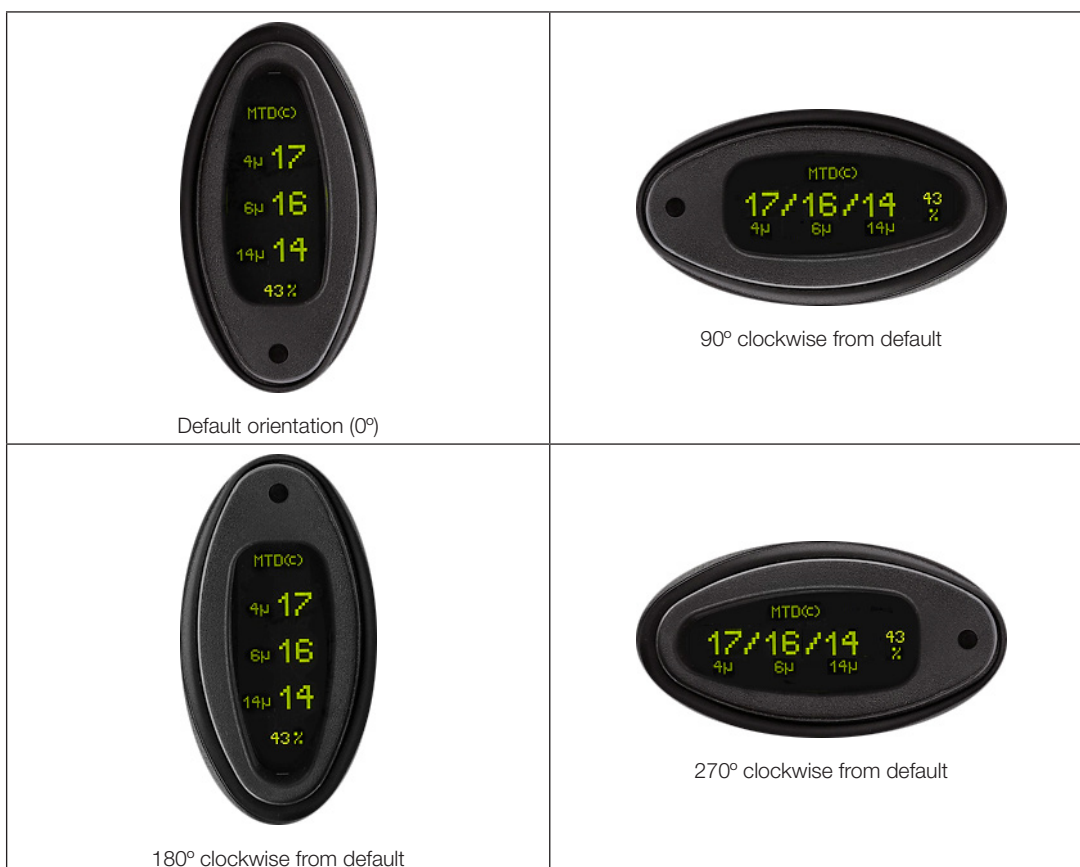



## Error detection

In the unlikely event of a error occurring, the normal display is completely replaced by an error code (for example, 'Error 13'). The error messages correspond to the following error code:

Code	Message
Error 0	No error
Error 1	Unknown command
Error 2	Characters after command ignored
Error 3	Command ignored – unit is busy
Error 5	Unexpected character found
Error 6	Symbol too long
Error 7	Bad command format
Error 8	Unknown value
Error 9	Invalid date format
Error 10	Invalid date
Error 13	Option not fitted
Error 14	String too short
Error 15	String too long
Error 17	No test result
Error 18	Number expected
Error 19	Number too long
Error 20	Number out of range
Error 30	Interval shorter than duration
Error 40	Expected On or Off
Error 41	Expected Disabled or Enabled
Error 43	Expected Auto or Manual
Error 45	Expected Yes or No

# Reference

## Optional wiring configuration

### 5 metre limit relay cable wiring configuration

The icountPD can be specified to include a built-in limit switch relay which can be triggered when a preset alarm level is reached. The relay contacts can be used to switch an external device on or off. Each wire within the icountPD limit relay cable is identified as **Red**, **White** and **Blue** which corresponds with the diagram below.

Wire colour	Description
Red	Normally Open
Blue	Normally Closed
White	Common

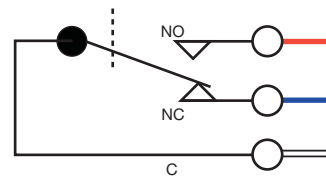

The contact rating is 5A at 5–24Vdc

**IMPORTANT NOTE:** It is the responsibility of the end user to ensure that the cable's braided screen is terminated.

## Optional limit relay hysteresis

*Hysteresis* is a property of systems (usually physical systems) that do not instantly follow the forces applied to them, but react slowly, or do not return completely to their original state.

To set Relay Limits, refer to the 'Communication Protocol – User Commands' section in this manual.

### HYSTERESIS FEATURE ON

The relay will energise when any channel is one code above the set limit (i.e. LEDs are **solid red**) and will only de-energize when all channels are one code below the set limit (i.e. All LEDs are **solid green**).

### HYSTERESIS FEATURE OFF

The relay will energise when any channel is one code above the set limit (i.e. LEDs are **solid red**) and will only de-energize when all channels are on the set limit (i.e. All LEDs are **flashing green**).

### EXAMPLE ISO SCENARIO

An icountPD has been connected to a hydraulic fluid transfer system. With the icountPD limit relay switched off (Normally Closed), the limits set to ISO 20/18/13 and the relay cable electrically connected to a Parker 10MFP Filtration Trolley. The icountPD will activate the 10MFP as soon as the set limits are breached. The ten test results below show the effect of having the hysteresis on or off:

	Hysteresis feature ON 10MFP Trolley status		Hysteresis feature OFF 10MFP Trolley status	
Test 1 result – 20/16/13	OFF		OFF	
Test 2 result – 21/16/13		ON		ON
Test 3 result – 20/16/13		ON	OFF	
Test 4 result – 18/17/14		ON		ON
Test 5 result – 18/16/13		ON	OFF	
Test 6 result – 17/16/11		ON		ON
Test 7 result – 17/16/11	OFF		OFF	
Test 8 result – 18/17/13	OFF		OFF	
Test 9 result – 19/17/14		ON		ON
Test 10 result – 19/17/13		ON	OFF	
ON = Relay activated, OFF = Relay not activated				

---

*NOTE: Electrical connection to a 10MFP Filtration Trolley requires the use of a relay*

---

### EXAMPLE NAS SCENARIO

An icountPD has been connected to a hydraulic system on a wind turbine. The icountPD limit relay is switched off (Normally Closed), the limits set to NAS 9 and the relay cable is connected to a Parker Guardian Filtration Unit. The icountPD activates the Guardian Filtration Unit as soon as the set limit is breached. The ten test results below show the effect of having the hysteresis on or off:

	Hysteresis feature ON Guardian Unit status		Hysteresis feature OFF Guardian Unit status	
Test 1 result = 9	OFF		OFF	
Test 2 result = 9	OFF		OFF	
Test 3 result = 10		ON		ON
Test 4 result = 9		ON	OFF	
Test 5 result = 10		ON		ON
Test 6 result = 8	OFF		OFF	
Test 7 result = 7	OFF		OFF	
Test 8 result = 10		ON		ON
Test 9 result = 9		ON	OFF	
Test 10 result = 10		ON		ON
ON = Relay activated, OFF = Relay not activated				

---

*NOTE: Electrical connection to a Guardian Filtration unit requires the use of a relay*

---

## Contamination Standards



See the Parker 'Guide to Contamination Standards' (DD0000015) – available on your CD. This publication makes available industry-recognized cleanliness specifications for both hydraulic fluid and fuel samples.



# Viscosity charts

The following charts indicate the differential pressure required to run a successful test at the appropriate flow rates.

Example: If the fluid you wish to analyse has a relative viscosity to 60 cSt, to generate the optimum flow rate 60ml/min a differential pressure of 0.5bar is required.

If the fluid you wish to analyse has a relative viscosity of 400 cSt, a 4 bar differential pressure would result in 130 ml/min.

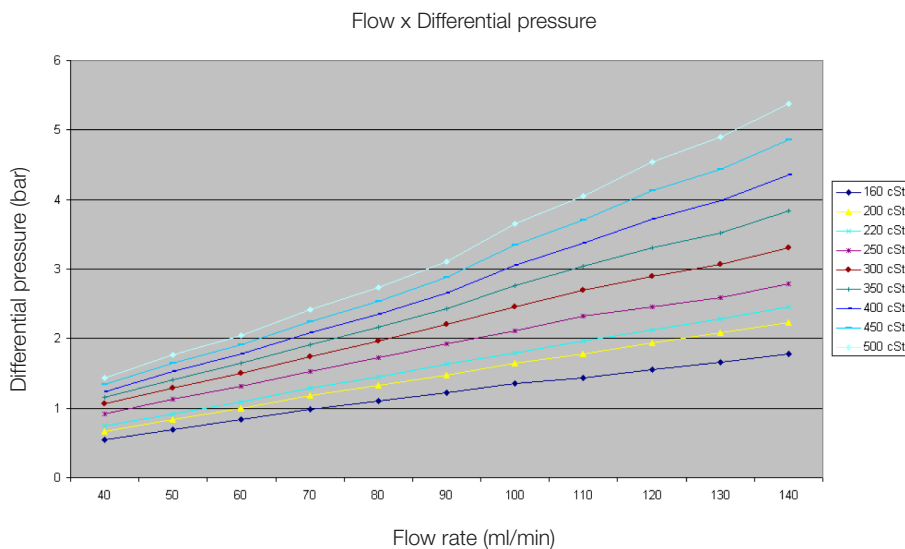
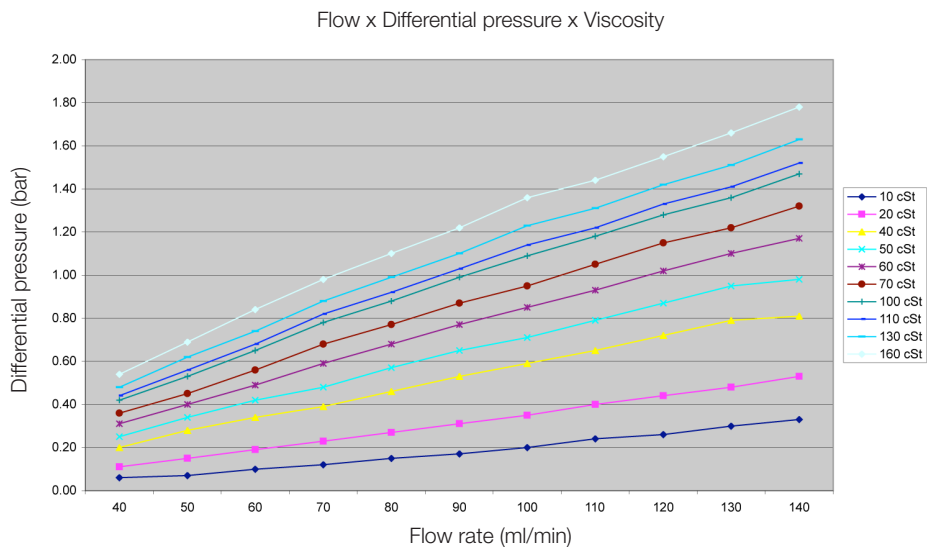

## icountPD-CAN version, SAE J1939 technical note

List of Default settings: These commands are now read/write by end-users through RS232 communication from the icountPD to **HyperTerminal** (or similar terminal emulation program).

These commands have been added to support user configuration of the CanBus J1939 option of the icountPD product. They are only accessible from icountPD software version 1.6.1 or later. If you require these options, please return your product to Parker Hannifin Manufacturing (UK) Ltd for the upgrade.

Command	Mnemonic	Default state	Definition
<b>RJP 0</b>	ENA	0x00	Protocol enable/disable
<b>RJP 1</b>	PTR	0x0A	Parameter Transmission Rate (Default 1s)
<b>RJP 2</b>	PS	0x00	PGN PS (Default to PGN 65280)
<b>RJP 3</b>	SA	0x00	Source address (Default to 0) (0–255 available)
<b>RJP 4</b>		0	N/A
<b>RJP 5</b>		0	N/A
<b>RJP 6</b>	PF	0xFF	PGN PF (Default to 65280)
<b>RJP 7</b>	SPNL	0xF7	SPN Low Byte (Default SPN 2551)
<b>RJP 8</b>	SPNH	0x09	SPN High Byte (Default SPN 2551)
<b>RJP 9</b>	IND	0x02	Industry Group (Default 2 = Agriculture/Forestry)

**NOTE:** It is advisable to make a note of any changes you make for future reference.

To **SET** the above states, launch HyperTerminal and with the unit reporting, enter **SJP** followed by the setting option you wish to change, **0** to **9**.

For example: To change the Source Address, enter **SJP 3** followed by your choice of source address between 0 and 255.

### GENERAL INFORMATION:

SAE J1939 protocol, 29-bit identifier, bus speed 250 kbit.

### OIL CLEANLINESS CLASS AND RELATIVE HUMIDITY

PGN	65280
Priority	6
TR	1s
ID (source addr.)	0 (default)

### DATA

STA	Byte 1
Data length	1 byte
Resolution	1/bit
Scaling offset	0
Unit	None

**STA** is the error check which reports whether a J1939 option is fitted. This is read by the main icountPD software but it can also be read via HyperTerminal by the user using the **ROF** (Read Options Fitted) command.

ENA	Byte 2
Data length	1 byte
Resolution	1/bit
Scaling offset	0
Unit	None

**ENA** is the error check which reports whether the J1939 is set to Enable. This is read and set by the main icountPD software but it can also be read via HyperTerminal by the end user using the **RJP 0** command; if enabled this will return a 1. If for some reason it returns a 0, you can change it to 1 by entering the command **SJP 0 1**.

## CONTAMINATION REPORT CHANNELS

CHA 4 $\mu$	Byte 3
Data length	1 byte
Resolution	1/bit
Scaling offset	0
Unit	4 $\mu$

CHB 6 $\mu$	Byte 4
Data length	1 byte
Resolution	1/bit
Scaling offset	0
Unit	6 $\mu$

CHC 14 $\mu$	Byte 5
Data length	1 byte
Resolution	1/bit
Scaling offset	0
Unit	14 $\mu$

CHD 30 $\mu$	Byte 6
Data length	1 byte
Resolution	1/bit
Scaling offset	0
Unit	30 $\mu$

This channel is used for 30 $\mu$  channel on fuel.

%RH	Byte 7
Data length	1 byte
Resolution	1/bit
Scaling offset	0
Unit	%RH

N/A	Byte 8
Data length	not used
Resolution	not used
Scaling offset	not used
Unit	not used

**SPNL****SPN low byte**

Under normal operation the product is restricted to SPN2551 (proprietary group B). This register is not acted on until the SPNH register is loaded.

**SPNH****SPN high byte**

Under normal operation the product is restricted to SPN2551 (proprietary group B). Loading this register causes the SPN to be set to 12-bit value given by SPNL:SPNH.

If the IPD is set to report a standard other than ISO – for example, NAS or AS4059 (cum) or (diff) – the J1939 PCB is sent the appropriate command from the main icountPD software to transmit the revised data.

The bytes for single-channel contamination data, for NAS and AS4059 (diff), are reported on the 4 $\mu$  channel, byte 3 – as shown in the following application file screen:

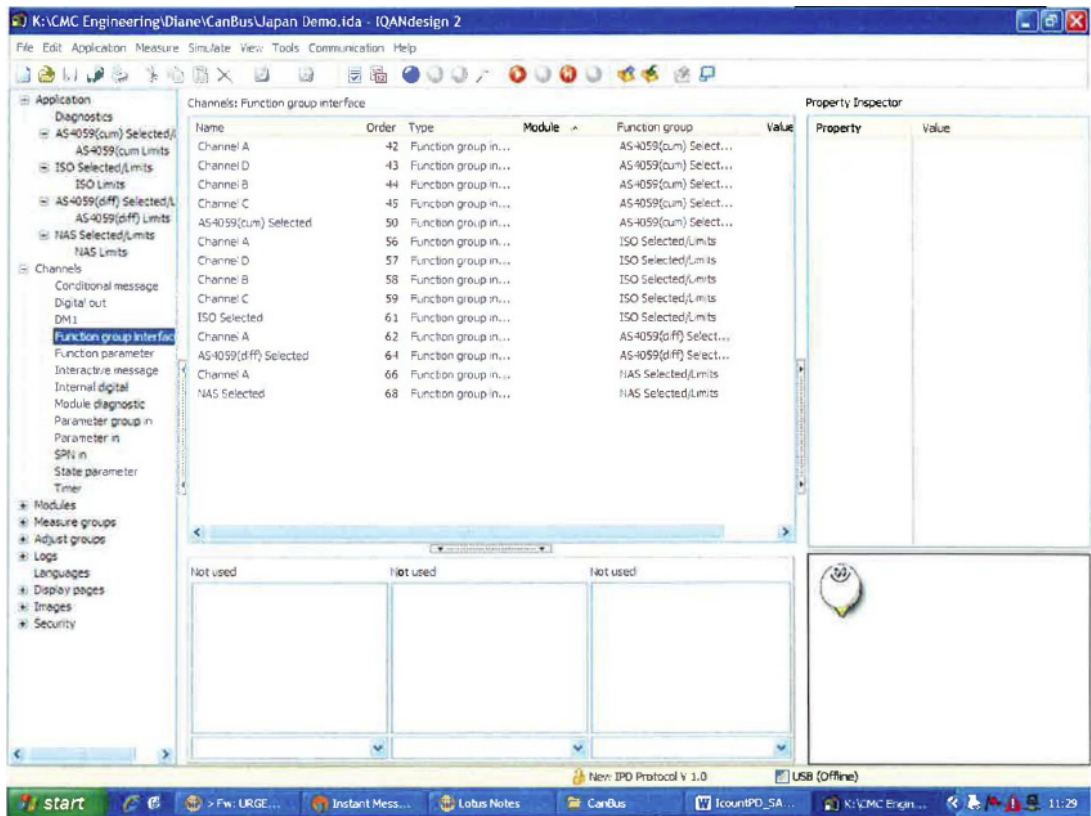

Example IQAN screen

**NOTE:** The CanBus termination resistor is built onto the PCB so an additional termination resistor should not be required when connecting to a Management Information System such as Parker's IQAN.



## Ordering Information

### STANDARD PRODUCTS TABLE

Part Number	Fluid type	Calibration	Display	Limit Relay	Communications	Moisture sensor	Cable connector kit
IPD12222130	Mineral	MTD	LED	Yes	RS232/4–20mA	No	M12, 8-pin plug connector
IPD12222230	Mineral	MTD	LED	Yes	RS232/4–20mA	Yes	M12, 8-pin plug connector
IPD12322130	Mineral	MTD	Digital	Yes	RS232/4–20mA	No	M12, 8-pin plug connector
IPD12322230	Mineral	MTD	Digital	Yes	RS232/4–20mA	Yes	M12, 8-pin plug connector
IPD12323130	Mineral	MTD	Digital	Yes	RS232/0–5V	No	M12, 8-pin plug connector
IPD12323230	Mineral	MTD	Digital	Yes	RS232/0–5V	Yes	M12, 8-pin plug connector
IPD12215210	Mineral	MTD	LED	No	RS232/CAN-bus	Yes	Deutsch 12-pin DT series connector

### PRODUCT CONFIGURATOR

Key	Fluid type		Calibration		Display		Limit Relay		Comms		Moisture sensor		Cable connector kit	
IPD	1	Mineral	1	ACFTD	1	None	1	No	1	RS232	1	No	00	No
IPDZ	2	Phosphate ester	2	MTD	2	LED	2	Yes	2	RS232 / 4–20mA	2	Yes	10	Deutsch 12-pin DT series connector
IPDR	3	Aviation fuel (4 channels)	3	AS4059	3	Digital			3	RS232 / 0–5V			30	M12, 8-pin plug connector
					4	GSM			4	RS232 / RS485				
					5				5	RS232 / CAN-bus				

### ACCESSORY PART NUMBERS

Description	Part number	
	Mineral oil	Aggressive fluid
1 metre hose length	ACC6NN001	ACC6NN002 **
2 metre hose length	ACC6NN003	ACC6NN004 **
5 metre hose length	ACC6NN005	ACC6NN006 **
Test Point ¼ inch BSP fitting	ACC6NN007	ACC6NN008
Test Point ⅛ inch BSP fitting	ACC6NN009	ACC6NN010
Test Point ⅛ inch NPT fitting	ACC6NN011	ACC6NN012
Single Point Sampler	SPS2021	SPS2061
External flow device	S840074	Contact Parker
Power supply	ACC6NN013	
5 metre M12, 8-pin plug and socket cable kit *	ACC6NN014	ACC6NN015
Deutsch 12-pin connector kit	ACC6NN016	
RS232 to USB converter	ACC6NN017	

\* The M12 cable kit consists of two 5 metre cables (a communications cable and a relay/power supply cable) that enable all output options.

\*\* Note that the Aggressive fluid hoses are provided as a single hose, not in pairs.

## SENSOR PART NUMBERS

Product number	Supersedes	Size	Flow range (l/min)	Fluid type	Port thread (inches)
STI0144100	STI.0144.100	0	6–25	Mineral fluid	3/8
STI1144100	STI.1144.100	1	20–100	Mineral fluid	3/4
STI2144100	STI.2144.100	2	80–380	Mineral fluid	1 1/4
STI0148100	STI.0148.100	0	6–25	Aggressive fluid	3/8
STI1148100	STI.1148.100	1	20–100	Aggressive fluid	3/4
STI2148100	STI.2148.100	2	80–380	Aggressive fluid	1 1/4



# Parker Worldwide

**AE – UAE, Dubai**  
Tel: +971 4 8875600  
parker.me@parker.com

**AR – Argentina, Buenos Aires**  
Tel: +54 3327 44 4129

**AT – Austria, Wiener Neustadt**  
Tel: +43 (0)2622 23501-0  
parker.austria@parker.com

**AT – Eastern Europe, Wiener Neustadt**  
Tel: +43 (0)2622 23501 970  
parker.easteurope@parker.com

**AU – Australia, Castle Hill**  
Tel: +61 (0)2-9634 7777

**AZ – Azerbaijan, Baku**  
Tel: +994 50 2233 458  
parker.azerbaijan@parker.com

**BE/LU – Belgium, Nivelles**  
Tel: +32 (0)67 280 900  
parker.belgium@parker.com

**BR – Brazil, Cachoeirinha RS**  
Tel: +55 51 3470 9144

**BY – Belarus, Minsk**  
Tel: +375 17 209 9399  
parker.belarus@parker.com

**CA – Canada, Milton, Ontario**  
Tel: +1 905 693 3000

**CH – Switzerland, Etoy**  
Tel: +41 (0) 21 821 02 30  
parker.switzerland@parker.com

**CN – China, Shanghai**  
Tel: +86 21 5031 2525

**CZ – Czech Republic, Klecany**  
Tel: +420 284 083 111  
parker.czechrepublic@parker.com

**DE – Germany, Kaarst**  
Tel: +49 (0)2131 4016 0  
parker.germany@parker.com

**DK – Denmark, Ballerup**  
Tel: +45 43 56 04 00  
parker.denmark@parker.com

**ES – Spain, Madrid**  
Tel: +34 902 33 00 01  
parker.spain@parker.com

**FI – Finland, Vantaa**  
Tel: +358 (0)20 753 2500  
parker.finland@parker.com

**FR – France, Contamine s/Arve**  
Tel: +33 (0)4 50 25 80 25  
parker.france@parker.com

**GR – Greece, Athens**  
Tel: +30 210 933 6450  
parker.greece@parker.com

**HK – Hong Kong**  
Tel: +852 2428 8008

**HU – Hungary, Budapest**  
Tel: +36 1 220 4155  
parker.hungary@parker.com

**IE – Ireland, Dublin**  
Tel: +353 (0)1 466 6370  
parker.ireland@parker.com

**IN – India, Mumbai**  
Tel: +91 22 6513 7081-85

**IT – Italy, Corsico (MI)**  
Tel: +39 02 45 19 21  
parker.italy@parker.com

**JP – Japan, Fujisawa**  
Tel: +(81) 4 6635 3050

**KR – South Korea, Seoul**  
Tel: +82 2 559 0400

**KZ – Kazakhstan, Almaty**  
Tel: +7 7272 505 800  
parker.easteurope@parker.com

**LV – Latvia, Riga**  
Tel: +371 6 745 2601  
parker.latvia@parker.com

**MX – Mexico, Apodaca**  
Tel: +52 81 8156 6000

**MY – Malaysia, Subang Jaya**  
Tel: +60 3 5638 1476

**NL – The Netherlands, Oldenzaal**  
Tel: +31 (0)541 585 000  
parker.nl@parker.com

**NO – Norway, Ski**  
Tel: +47 64 91 10 00  
parker.norway@parker.com

**NZ – New Zealand, Mt Wellington**  
Tel: +64 9 574 1744

**PL – Poland, Warsaw**  
Tel: +48 (0)22 573 24 00  
parker.poland@parker.com

**PT – Portugal, Leca da Palmeira**  
Tel: +351 22 999 7360  
parker.portugal@parker.com

**RO – Romania, Bucharest**  
Tel: +40 21 252 1382  
parker.romania@parker.com

**RU – Russia, Moscow**  
Tel: +7 495 645-2156  
parker.russia@parker.com

**SE – Sweden, Spånga**  
Tel: +46 (0)8 59 79 50 00  
parker.sweden@parker.com

**SG – Singapore**  
Tel: +65 6887 6300

**SK – Slovakia, Banská Bystrica**  
Tel: +421 484 162 252  
parker.slovakia@parker.com

**SL – Slovenia, Novo Mesto**  
Tel: +386 7 337 6650  
parker.slovenia@parker.com

**TH – Thailand, Bangkok**  
Tel: +662 717 8140

**TR – Turkey, Istanbul**  
Tel: +90 216 4997081  
parker.turkey@parker.com

**TW – Taiwan, Taipei**  
Tel: +886 2 2298 8987

**UA – Ukraine, Kiev**  
Tel +380 44 494 2731  
parker.ukraine@parker.com

**UK – United Kingdom, Warwick**  
Tel: +44 (0)1926 317 878  
parker.uk@parker.com

**US – USA, Cleveland**  
Tel: +1 216 896 3000

**VE – Venezuela, Caracas**  
Tel: +58 212 238 5422

**ZA – South Africa, Kempton Park**  
Tel: +27 (0)11 961 0700  
parker.southafrica@parker.com

[www.parker.com/hfde](http://www.parker.com/hfde)

European Product Information Centre  
(24-hour)

Freephone: +00800 27 27 5374

(from AT, BE, CH, CZ, DE, EE, ES, FI,  
FR, IE, IT, PT, SE, SK, UK)

© 2015 Parker Hannifin Corporation.  
All rights reserved.

B.84.833\_IPD\_EN Rev 3

