

| Input pressure range ¹ | | | | | | | |
|--|---------------------|------|-----|----|----|-----|-----|
| Nominal pressure gauge | [bar] | 0.40 | 1 | 2 | 4 | 10 | 20 |
| Level | [mH ₂ O] | 4 | 10 | 20 | 40 | 100 | 200 |
| Overpressure | [bar] | 2 | 5 | 10 | 20 | 40 | 80 |
| Burst pressure ≥ | [bar] | 3 | 7.5 | 15 | 25 | 50 | 120 |
| Max. ambient pressure (housing): 40 bar | | | | | | | |
| ¹ On customer request we adjust the device within the turn-down-possibility by software on the required pressure range. | | | | | | | |

| Output signal / Supply | |
|------------------------|--|
| Standard | 2-wire: 4 ... 20 mA / V _S = 12 ... 36 V _{DC} |
| Option IS-version | 2-wire: 4 ... 20 mA / V _S = 14 ... 28 V _{DC} |
| Options 3-wire | 3-wire: 0 ... 10 V / V _S = 14 ... 36 V _{DC} |
| Performance | |
| Accuracy ² | nominal pressure ≥ 0.1 bar: ≤ ± 0.1 % FSO nominal pressure < 0.1 bar: ≤ ± 0.2 % FSO |
| Permissible load | current 2-wire: R _{max} = [(V _S - V _{S min}) / 0.02 A] Ω voltage 3-wire: R _{min} = 10 kΩ |
| Influence effects | supply: 0.05 % FSO / 10 V load: 0.05 % FSO / kΩ |
| Long term stability | ≤ ± 0.1 % FSO / year at reference conditions |
| Response time | ca. 200 msec |

² accuracy according to IEC 60770 – limit point adjustment (non-linearity, hysteresis, repeatability)

| Thermal effects (offset and span) | |
|-----------------------------------|--|
| Tolerance band | ≤ ± 0.2 % FSO in compensated range -20 ... 80°C |
| TC | ± 0.02 % FSO / 10K in compensated range -20 ... 80°C |

| Permissible temperatures | |
|--------------------------|--|
| Permissible temperatures | medium: -10 ... 70 °C storage: -25 ... 70 °C |

| Electrical protection ³ | |
|------------------------------------|---|
| Insulation resistance | > 100 MΩ |
| Reverse polarity protection | no damage, but also no function |
| Electromagnetic compatibility | emission and immunity according to EN 61326 |

³ additional external overvoltage protection unit in terminal box KL 1 or KL 2 with atmospheric pressure reference available on request

| Electrical connection | |
|---|--|
| Cable with sheath material ⁴ | PVC (-5 ... 70 °C) grey Ø 7.4 mm PUR (-10 ... 70 °C) black Ø 7.4 mm FEP ⁵ (-10 ... 70 °C) black Ø 7.4 mm TPE-U (-10 ... 70 °C) blue Ø 7.4 mm (without/with drinking water certificate) |
| Bending radius | static installation: 10-fold cable diameter dynamic application: 20-fold cable diameter |

⁴ shielded cable with integrated ventilation tube for atmospheric pressure reference

⁵ do not use freely suspended probes with an FEP cable if effects due to highly charging processes are expected

| Materials (media wetted) | |
|--------------------------|--|
| Housing | stainless steel 1.4404 (316L) |
| Seals | FKM EPDM (without/with drinking water certificate) others on request |
| Diaphragm | stainless steel 1.4435 (316L) |
| Protection cap | POM-C |
| Cable sheath | PVC, PUR, FEP, TPE-U |

| Explosion protection (only for 4 ... 20 mA / 2-wire) | |
|--|---|
| Approvals DX19-LMP 307i | IBExU 10 ATEX 1068 X / IECEx IBE 12.0027X zone 0: II 1G Ex ia IIC T4 Ga zone 20: II 1D Ex ia IIIC T135 °C Da |
| Safety technical maximum values | U _i = 28 V, I _i = 93 mA, P _i = 660 mW, C _i ≈ 0 nF, L _i ≈ 0 μH, the supply connections have an inner capacity of max. 27 nF to the housing |
| Permissible temperatures for environment | in zone 0: -20 ... 60 °C with p _{atm} 0.8 bar up to 1.1 bar in zone 1 or higher: -40/-20 ... 65 °C |
| Connecting cables (by factory) | cable capacitance: signal line/shield also signal line/signal line: 160 pF/m cable inductance: signal line/shield also signal line/signal line: 1 μH/m |

| Miscellaneous | |
|--|---|
| Drinking water certificate ⁶ | according to DVGW W 270 and UBA KTW (with order the indication "with drinking water certificate" is necessary) |
| Current consumption | signal output current: max. 25 mA signal output voltage: max. 7 mA |
| Weight | approx. 200 g (without cable) |
| Ingress protection | IP 68 |
| CE-conformity | EMC Directive: 2014/30/EU |
| ATEX Directive | 2014/34/EU |
| ⁶ only possible with EPDM seal in combination with TPE-U cable; not possible with IS-version (explosion protection) | |
| Wiring diagrams | |
| <p>2-wire-system (current)</p> | <p>3-wire-system (current / voltage)</p> |
| Pin configuration | |
| Electrical connection | cable colours (IEC 60757) |
| Supply + | WH (white) |
| Supply - | BN (brown) |
| Signal + (only 3-wire) | GN (green) |
| Shield | GNYE (green-yellow) |
| Dimensions (mm / in) | |
| <p style="text-align: right;">protection cap removable</p> | |

Mounting flange with cable gland

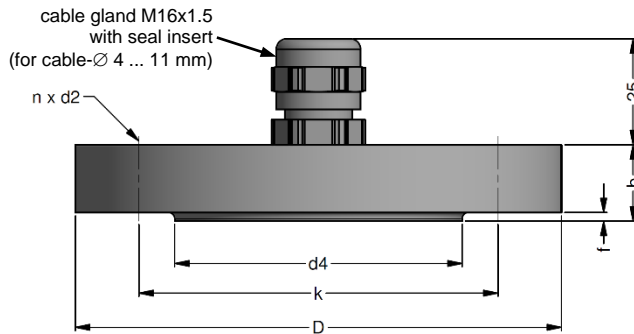

| dimensions in mm | | | |
|------------------|-------------|-------------|-------------|
| size | DN25 / PN40 | DN50 / PN40 | DN80 / PN16 |
| b | 18 | 20 | 20 |
| D | 115 | 165 | 200 |
| d2 | 14 | 18 | 18 |
| d4 | 68 | 102 | 138 |
| f | 2 | 3 | 3 |
| k | 85 | 125 | 160 |
| n | 4 | 4 | 8 |

| Technical data | | |
|---|---|--------|
| Suitable for | all probes | |
| Flange material | stainless steel 1.4404 (316L) | |
| Material of cable gland | standard: brass, nickel plated on request: stainless steel 1.4305 (303); plastic | |
| Seal insert | material: TPE (ingress protection IP 68) | |
| Hole pattern | according to DIN 2507 | |
| Ordering type | Ordering code | Weight |
| DN25 / PN40 with cable gland brass, nickel plated | ZMF2540 | 1.4 kg |
| DN50 / PN40 with cable gland brass, nickel plated | ZMF5040 | 3.2 kg |
| DN80 / PN16 with cable gland brass, nickel plated | ZMF8016 | 4.8 kg |

Terminal clamp



| Technical data | | |
|---|--|---------------|
| Suitable for | all probes with cable Ø 5.5 ... 10.5 mm | |
| Material of housing | standard: steel, zinc plated optionally: stainless steel 1.4301 (304) | |
| Material of clamping jaws and positioning clips | PA (fibre-glass reinforced) | |
| Dimensions (mm) | 174 x 45 x 32 | |
| Hook diameter | 20 mm | |
| Ordering type | Ordering code | Weight |
| Terminal clamp, steel, zinc plated | Z100528 | approx. 160 g |
| Terminal clamp, stainless steel 1.4301 (304) | Z100527 | |

Display program

- CIT 200** Process display with LED display
- CIT 250** Process display with LED display and contacts
- CIT 300** Process display with LED display, contacts and analogue output
- CIT 350** Process display with LED display, bargraph, contacts and analogue output
- CIT 400** Process display with LED display, contacts, analogue output and Ex-approval
- CIT 600** Multichannel process display with graphics-capable LC display
- CIT 650** Multichannel process display with graphics-capable LC display and datalogger
- CIT 700 / CIT 750** Multichannel process display with graphics-capable TFT monitor, touchscreen and contacts
- PA 440** Field display with 4-digit LC display

For further information please contact our sales department or visit our homepage:
<http://www.bdsensors.de>



© 2022 BD|SENSORS GmbH – The specifications given in this document represent the state of engineering at the time of publishing. We reserve the right to make modifications to the specifications and materials.

