



# GHIBSON

valves

**Butterfly  
valves**

**SOFT  
Seated**

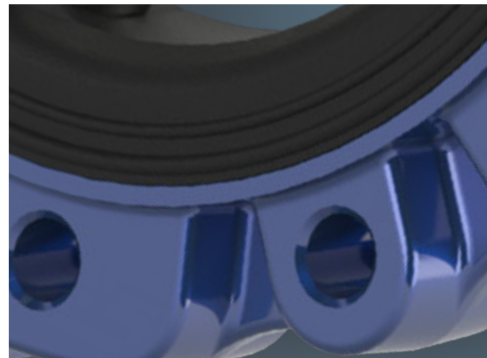
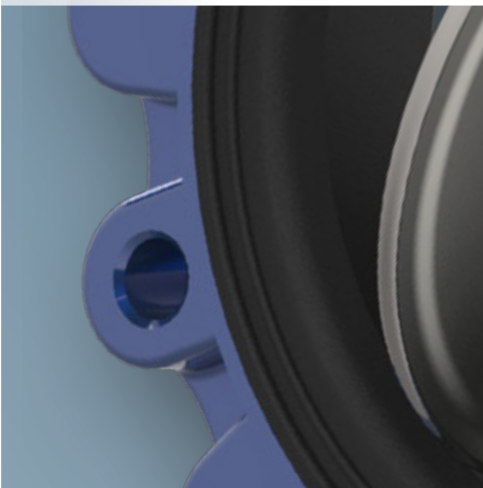
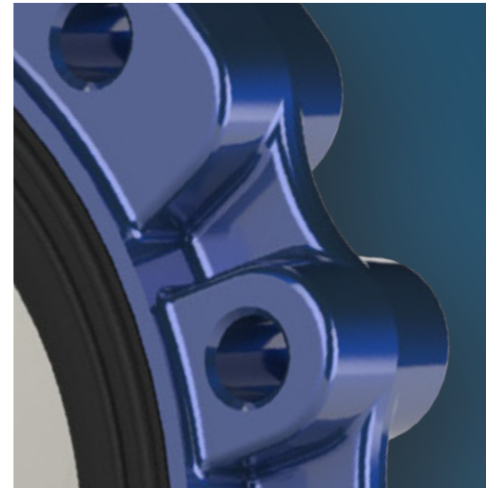
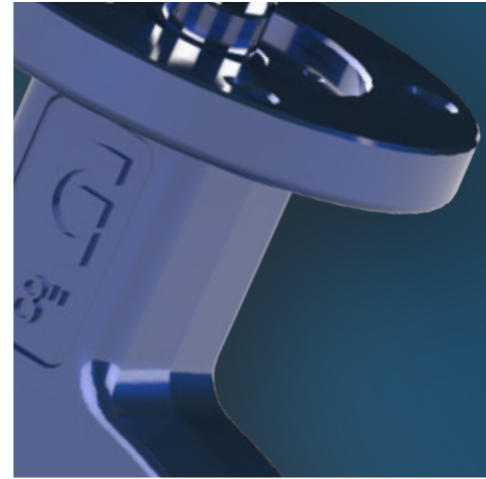
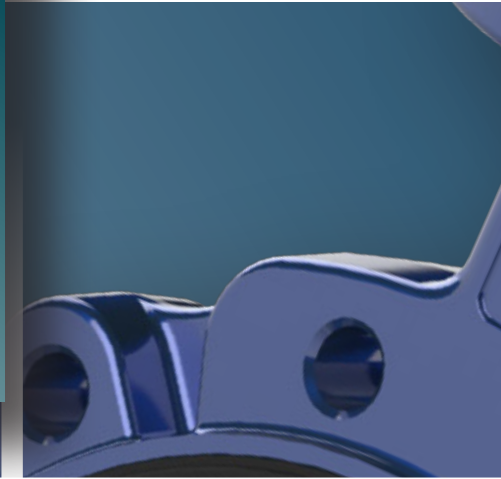



# Butterfly valves

## Double eccentric HD Series

### **BVPD - Wafer BLPD - Lug** **DN 80 - 600 • 3" - 24"**

Soft seated butterfly valves  
P max: **10 Bar** designed for low pressures and powder convey

### **BVKI - Wafer BLKI - Lug** **DN 40 - 800 • 1" 1/4 - 32"**

Soft seated butterfly valves  
P max: **16 Bar** designed for all applications

### **BFKI - double flange** **DN 80 - 600 • 3" - 24"**

Soft seated butterfly valves  
P max: **16 Bar** double flanged

### **BVKA - Wafer BLKA - Lug** **DN 40 - 800 • 1" 1/4 - 32"**

Soft seated butterfly valves  
P max: **20 Bar**

### **BVKX - Wafer BLKX - Lug** **DN 50 - 250 • 2" - 10"**

Soft seated butterfly valves  
P max: **25 Bar**

**GIBSON** Soft seated butterfly valves are designed to meet with most industrial applications, from powder conveyance to petrochemical requirements.

The valves are manufactured in four different versions with sizes from DN 40 to DN 800, pressures up to 25 bar and many different materials.

We can supply valves

- manually operated (with levers or gearboxes)
- pneumatically operated (with double or single acting actuators)
- electrically or hydraulically operated

We also offer special solutions in many different materials.

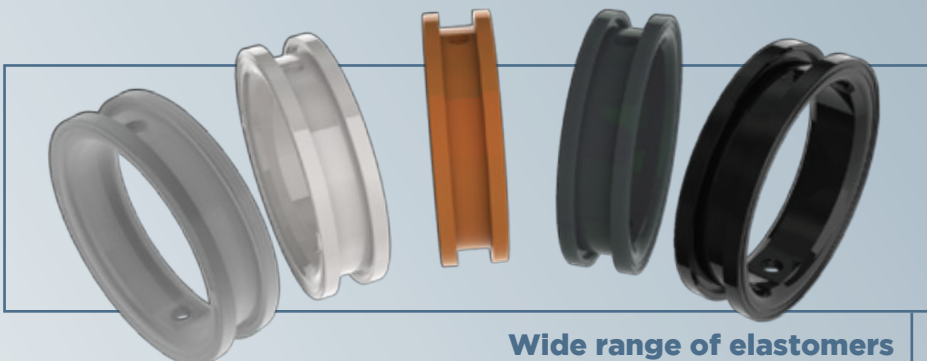
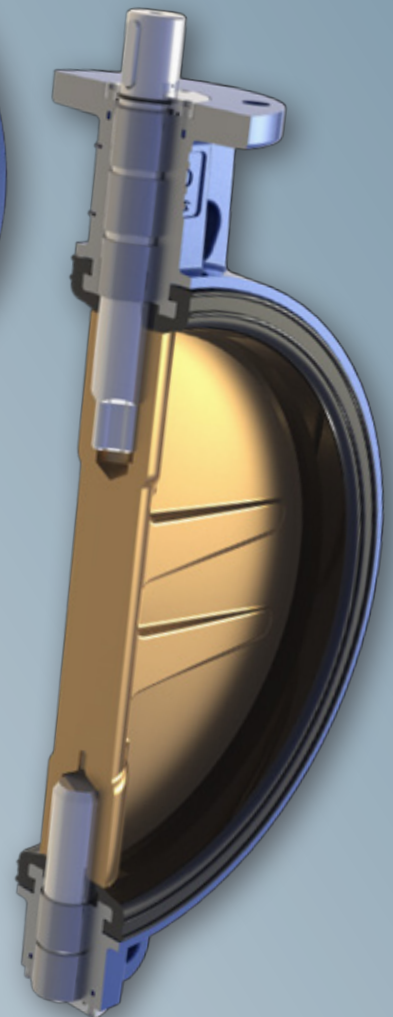
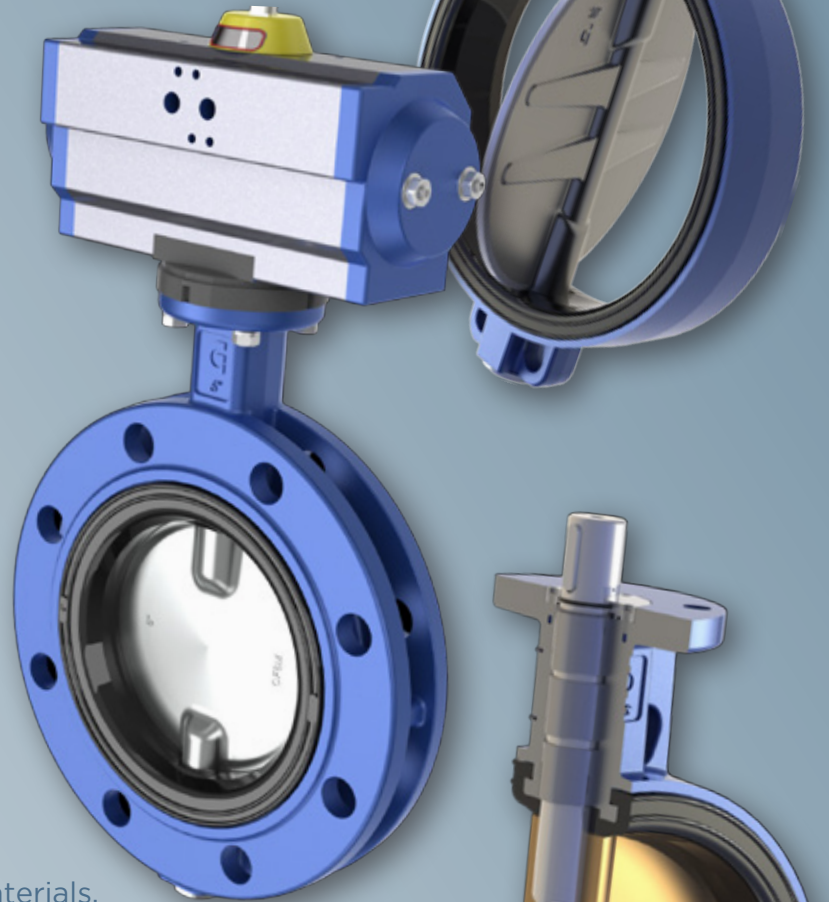
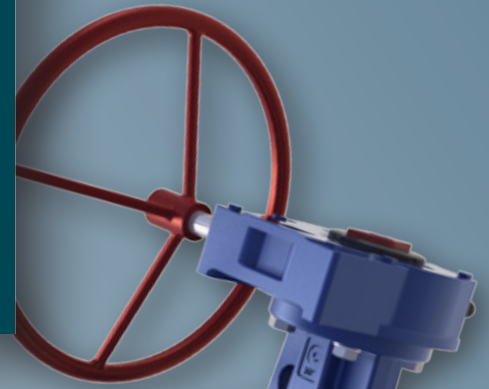

### **Wide range of elastomers**

**A very wide range of elastomers allows the best combination of materials depending on the different applications**



### Detail of shaft-disc connection

Valves over DN300 have a special designed shaft-disc connection which ensures a strong coupling while avoiding clearances and gives higher shaft tensile capacity thanks to the section considerably larger than the classic square section.

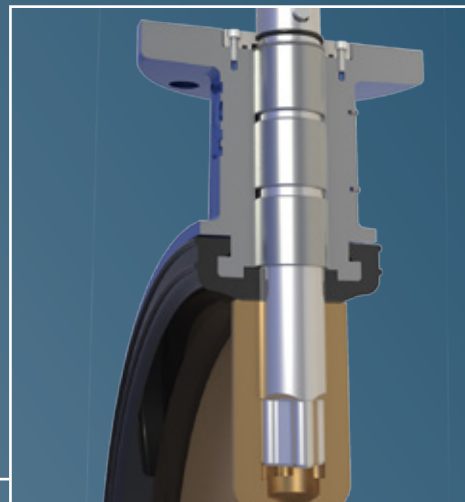

### Special shaft double packing

Sealing outwards is ensured by a double packing at the top and at the bottom of the shaft.

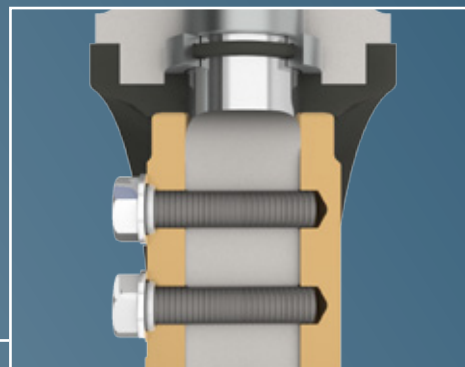

### Detail of lower support

The adjustable lower support prevents the shaft-disc unit to move along the axis. Furthermore when the valve is assembled with vertical shaft, the disc does not weigh on the seat with a longer duration of valve life.

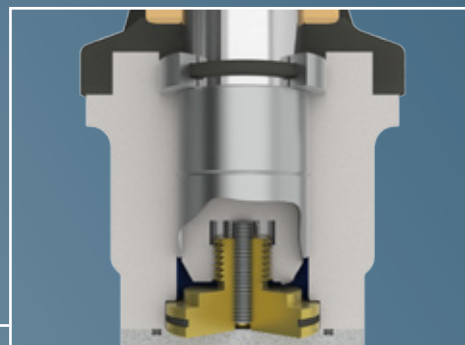

All GIBSON butterfly valves have anti-blow out system for the shafts in compliance with EN736 and API609 standards

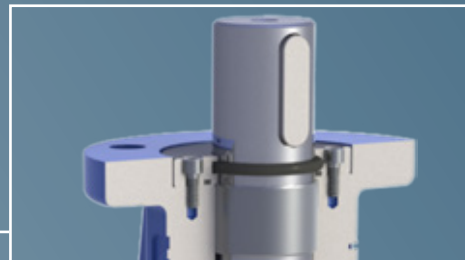

### Detail of shaft-disc fastening

For valves over DN500 this solution allows a strong fastening without clearances and easy maintenance.



### Detail of replaceable body seat

Its shape ensures the best anchoring to the body even in hard applications.

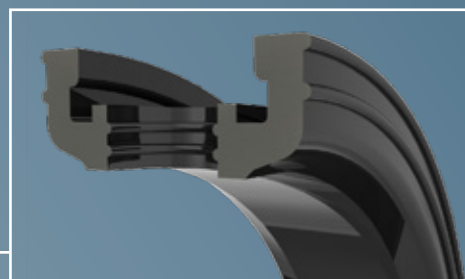



# Butterfly valves

## SOFT SEATED

Ghibson soft seated butterfly valves (PD, KI, KA and KX series) are designed to fit in industrial applications from powder conveyance to marine and petrochemical requirements.

They are manufactured in different versions and materials and for working pressures from 6 to 25 Bars.



<b>PD, KI Series</b>	<b>1</b>
• technical data	1
• components DN 80-300	2
• components DN 350-500	3
• components DN 600-800	4
<b>KA, KX technical data</b>	<b>5</b>
• technical data	5
<b>KA series</b>	<b>6</b>
• components DN 40-300	6
• components DN 350-400	7
• components DN 450-500	8
• components DN 600-800	9
<b>KX series</b>	<b>10</b>
• components DN 50-250	10
<b>PD, KI, KA Series</b>	<b>11</b>
• dimensions tables	11
<b>BFKI, BVKX, BLKX Series</b>	<b>12</b>
• dimensions tables	12
<b>Torque values tables</b>	<b>13</b>
<b>Head losses tables</b>	<b>14</b>
<b>Flanges</b>	<b>15</b>
<b>bolts and rods dimensions</b>	<b>16</b>
<b>Installation instructions</b>	<b>17</b>
<b>Handler</b>	<b>18</b>
<b>Gearbox</b>	<b>19</b>
• aluminium body	19
• cast iron body	20
<b>Actuators and coupling</b>	<b>21</b>
• pneumatic actuators	21
• declutchable gearboxes	23
• emergency handler	23
• hydraulic actuators	24

Ghibson Italia srl reserves the right to change and/or update data/content without previous notice.

GHIBSON  
Zola Predosa  
Bologna





### BVPD-Wafer BLPD-Lug DN 80 - 600 • 3" - 24"

### BVKI - Wafer BLKI - Lug DN 40 - 800 • 1 1/2" - 32"

### BFKI - double flange DN 80 - 600 • 3" - 24"

#### Max working pressure:

BVPD/BLPD DN80÷600: Flange: <b>PN 6-10-16 • A150</b>	<b>10 Bar</b>
BVKI/BLKI DN40÷500: Flange: <b>PN 10-16 • A150</b>	<b>16 Bar</b>
BVKI/BLKI DN600÷800: Flange: <b>PN 6-10-16 • A150</b>	<b>10 Bar</b>
BFKI DN80÷600: Flange: <b>PN 10-16 • A150</b>	<b>16 Bar</b>

#### KI series to be used also with vacuum

#### Design:

EN 593 ~ EN 736 ~ EN 12516 ~ EN 1092  
ISO 5211 ~ DIN 3337 ~ API 609  
PED 2014/68/EU - Mod. H

#### Face to face:

DIN EN 558-1 Series 20 ~ ISO 5752 Series 20  
BS-5155 Series 4 ~ MSS-SP67  
API609 cat.A ~ NFE 29305-1

#### Testing:

EN 12266-1 Rate A (supersedes DIN 3230)  
ISO 5208 Rate A ~ API 598

#### Tag:

EN 19 ~ MSS SP-25

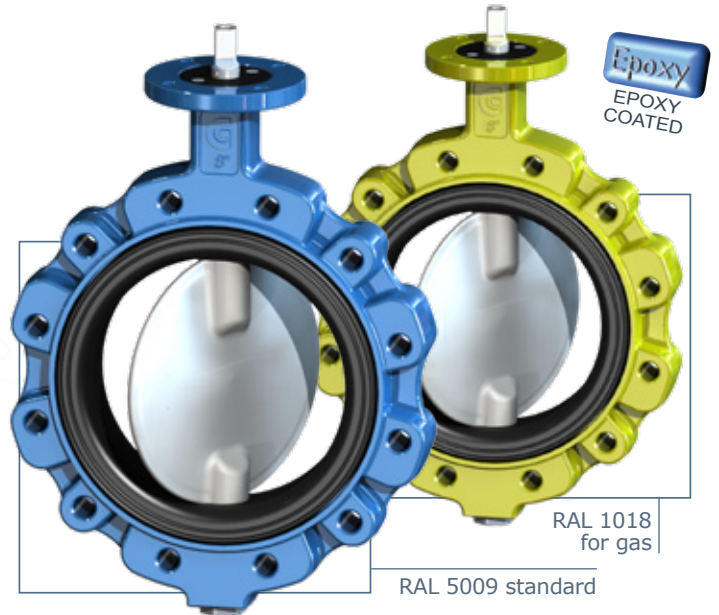

All valves are supplied with a metallic label in compliance with PED directive.

BODY			BVPD	BVKI/BLKI	BFKI
material	references	standard coating	DN	DN	DN
Ductile iron	EN-GJS 400-15 (GS400)	Epoxy RAL 5009	80-600	40-800	80-600
Carbon steel	ASTM A216-WCB	Epoxy RAL 9005	80-600	40-800	-
Stainless steel	ASTM A351 CF8M (A316)	-	80-600	40-800	-
Aluminium-bronze	ASTM B148-C958.00	-	80-600	40-800	-
Aluminium (P <sub>max</sub> 10Bar)	EN AB 46400	Epoxy RAL 7024	80-500	40-500 only wafer	-

DISC			BVPD	BVKI/BLKI	BFKI
material	references	standard coating	DN	DN	DN
Steel	ASTM A105	Zinc	80-100	50-100	80-100
Ductile iron	EN-GJS 400-15 (GS400)	Zinc	125-600	125-800	125-600
Stainless steel	ASTM A351 CF8M (A316)	-	80-600	40-800	80-600
Aluminium-bronze	ASTM B148-C958.00	-	80-600	40-800	80-600
Hastelloy®	ASTM A494 CX2MW	-	80-600	40-800	80-600
Monel®	ASTM A494 M35-1	-	80-600	40-800	80-600

BODY RUBBER SEAT			DN 40/500 replaceable - DN 600/800 vulcanized not replaceable				
ref.	designation	PD 6bar	PD 10bar	KI	trade name	working temp.	applications
NBR	nitrile rubber	✓	✓	✓	BUNA®	-25°C / +100°C	oils, hydrocarbons, gas, air, water
EPDM	copolymer EPDM	✓	✓	✓	-	-35°C / +130°C	water, sea water, steam, diluted acids
EPDM HT	copolimery EPDM HT	✓	✓	✓	-	-30°C / +135°C	water, sea water, steam, diluted acids
CO	carboxide	✓	✗	✓	-	-25°C / +100°C	dust, air
FKM	fluoroelastomer	✓	✗	✓	VITON®	-20°C / +200°C	oils, acids, hydrocabons
CR	polychloroprene	✓	✗	✓	NEOPRENE®	-20°C / +100°C	alkali, bases, water
NR	natural rubber	✓	✗	✓	-	-40°C / + 80°C	glycols, abrasive media
MVQ	silicon rubber	✓	✗	✓	SILOPREN®	-60°C / +190°C	water, food, drinks
CSM	chlorosulfonated polyethylene	✓	✗	✓	HYPALON®	-20°C / +125°C	acids, mineral bases, alcohols, hydrocarbons
PU	poliuretane	✓	✓	✓	POLIURETANE®	-25°C / +90°C	abrasive media

On request can be supplied other materials as: LCB, Hastelloy, Monel, Uranus, Alloy, DUPLEX, Special steels, Special bronzes.  
Coating on request: RILSAN®, Halar®, Chenisil®



**BVPD-Wafer BLPD-Lug**  
**DN 80 - 300 • 3" - 12"**  
**PN 6-10-16 • ANSI 150**

**BVKI - Wafer BLKI - Lug**  
**DN 40 - 300 • 1 1/2" - 12"**  
**PN 10-16 • ANSI 150**

**BFKI - double flange**  
**DN 80 - 300 • 3" - 12"**  
**PN 10-16 • ANSI 150**

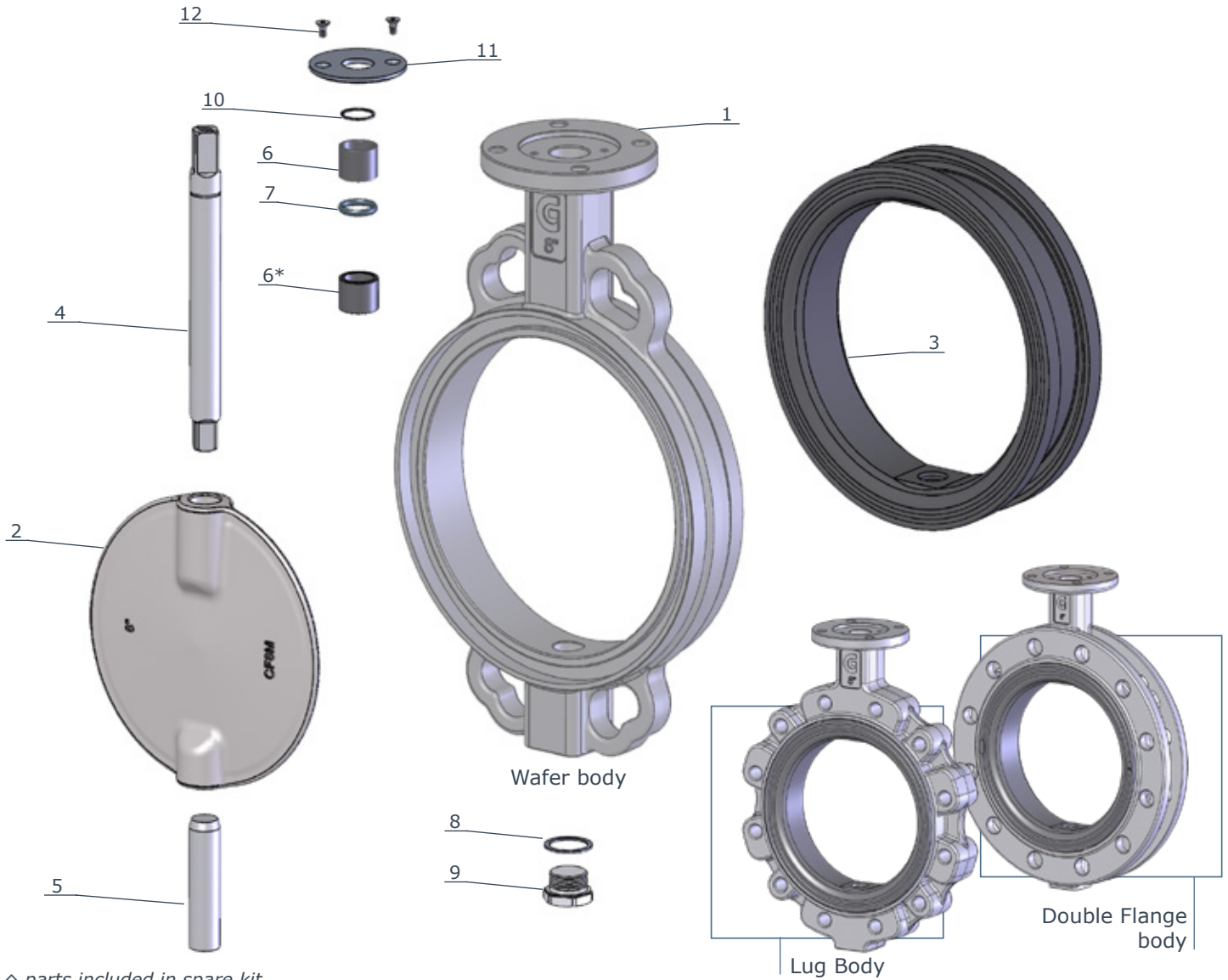

◇ parts included in spare kit

item	q.ty	part	material
1	1	body (BFKI only GS400)	<ul style="list-style-type: none"> <li>ductile iron GS400</li> <li>A216 - WCB</li> <li>A352 - LCB</li> <li>A351 - CF8M (AISI 316)</li> <li>aluminium-bronze</li> <li>aluminium (only WAFER)</li> </ul>
2	1	disc	<ul style="list-style-type: none"> <li>ductile iron GS400</li> <li>A351 - CF8M (AISI 316)</li> <li>aluminium-bronze</li> <li>Hastelloy®</li> <li>Monel®</li> </ul>
◇3	1	body seat (replaceable)	<ul style="list-style-type: none"> <li>NBR (BUNA®)</li> <li>EPDM</li> <li>EPDM HT</li> <li>FKM (VITON®)</li> <li>carboxide</li> <li>polychloroprene (NEOPRENE®)</li> <li>natural rubber</li> <li>silicon</li> </ul>

item	q.ty	part	material
4	1	upper shaft	<ul style="list-style-type: none"> <li>AISI 430</li> <li>AISI 316 (on request)</li> </ul>
5	1	lower shaft	<ul style="list-style-type: none"> <li>AISI 430</li> <li>AISI 316 (on request)</li> </ul>
◇6	1	bush	bronze
◇6*	3	bush	<ul style="list-style-type: none"> <li>A105+PTFE</li> <li>A316+PTFE (only Inox body)</li> </ul>
◇7	1	shaft packing	<ul style="list-style-type: none"> <li>NBR (BUNA®)</li> <li>FKM (VITON®) on request</li> </ul>
8	1	plug packing	aluminium
9	1	threaded plug	zinc plated steel
10	1	stop ring	steel
11	1	upper flange	<ul style="list-style-type: none"> <li>IXEF (DN 40-150)</li> <li>aluminium (DN 200-300)</li> </ul>
12	2	screw	zinc plated steel

\* only for DN300



**BVPD-Wafer BLPD-Lug**  
**DN 350 - 500 • 14" - 20"**  
**PN 6-10-16 • ANSI 150**

**BVKI - Wafer BLKI - Lug**  
**DN 350 - 500 • 14" - 20"**  
**PN 10-16 • ANSI 150**

**BFKI - double flange**  
**DN 350 - 500 • 14" - 20"**  
**PN 10-16 • ANSI 150**

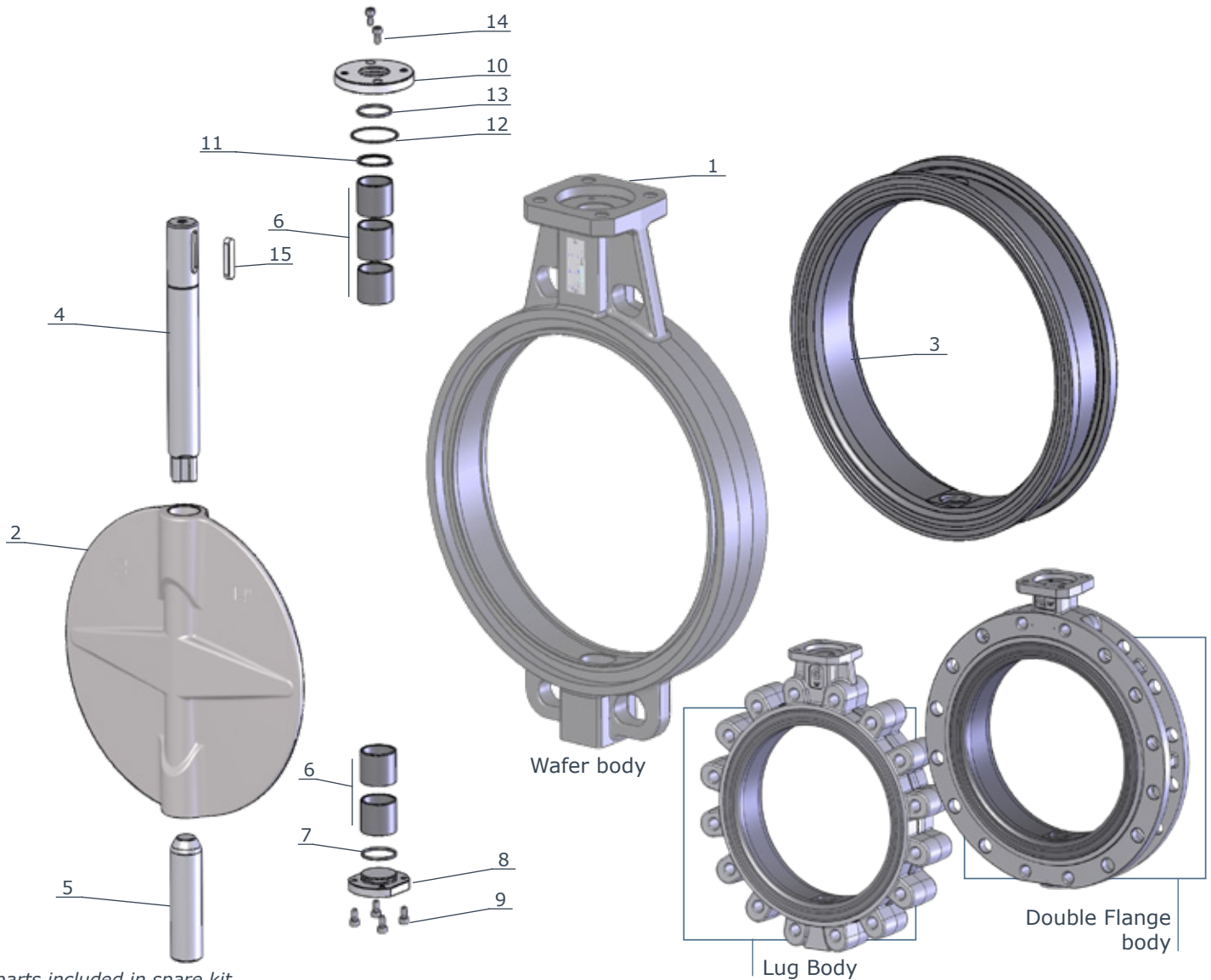

◇ parts included in spare kit

item	q.ty	part	material
1	1	body (BFKI only GS400)	<ul style="list-style-type: none"> <li>ductile iron GS400</li> <li>A216-WCB</li> <li>A352-LCB</li> <li>A351-CF8M (AISI 316)</li> <li>aluminium-bronze</li> <li>aluminium (only WAFER)</li> </ul>
2	1	disc	<ul style="list-style-type: none"> <li>ductile iron GS400</li> <li>A351-CF8M (AISI 316)</li> <li>aluminium-bronze</li> <li>Hastelloy®</li> <li>Monel®</li> </ul>
◇3	1	body seat (replaceable)	<ul style="list-style-type: none"> <li>NBR (BUNA®)</li> <li>EPDM</li> <li>EPDM HT</li> <li>FKM (VITON®)</li> <li>carboxide</li> <li>polychloroprene (NEOPRENE®)</li> <li>natural rubber</li> <li>silicon</li> </ul>
4	1	upper shaft	<ul style="list-style-type: none"> <li>AISI 430</li> <li>AISI 316 (on request)</li> </ul>

item	q.ty	part	material
5	1	lower shaft	<ul style="list-style-type: none"> <li>AISI 430</li> <li>AISI 316 (on request)</li> </ul>
◇6	5	bush	<ul style="list-style-type: none"> <li>bronze</li> <li>steel+PTFE (DN 450-500)</li> </ul>
◇7	1	packing lower flange	<ul style="list-style-type: none"> <li>NBR (BUNA®)</li> </ul>
8	1	lower flange	<ul style="list-style-type: none"> <li>zinc plated steel</li> </ul>
9	4	screw	<ul style="list-style-type: none"> <li>zinc plated steel</li> </ul>
10	1	upper flange	<ul style="list-style-type: none"> <li>zinc plated steel</li> </ul>
11	1	stop ring	<ul style="list-style-type: none"> <li>steel</li> </ul>
◇12	1	O.Ring	<ul style="list-style-type: none"> <li>NBR (BUNA®)</li> </ul>
◇13	1	O.Ring	<ul style="list-style-type: none"> <li>NBR (BUNA®)</li> </ul>
14	2	screw	<ul style="list-style-type: none"> <li>zinc plated steel</li> </ul>
15	1	key	<ul style="list-style-type: none"> <li>steel C40</li> </ul>



**BVPD-Wafer BLPD-Lug**  
**DN 600 • 24"**  
**PN 6-10-16 • ANSI 150**

**BVKI - Wafer BLKI - Lug**  
**DN 600 - 800 • 24" - 32"**  
**PN 6-10-16 • ANSI 150**

**BFKI - double flange**  
**DN 600 • 24"**  
**PN 10-16 • ANSI 150**

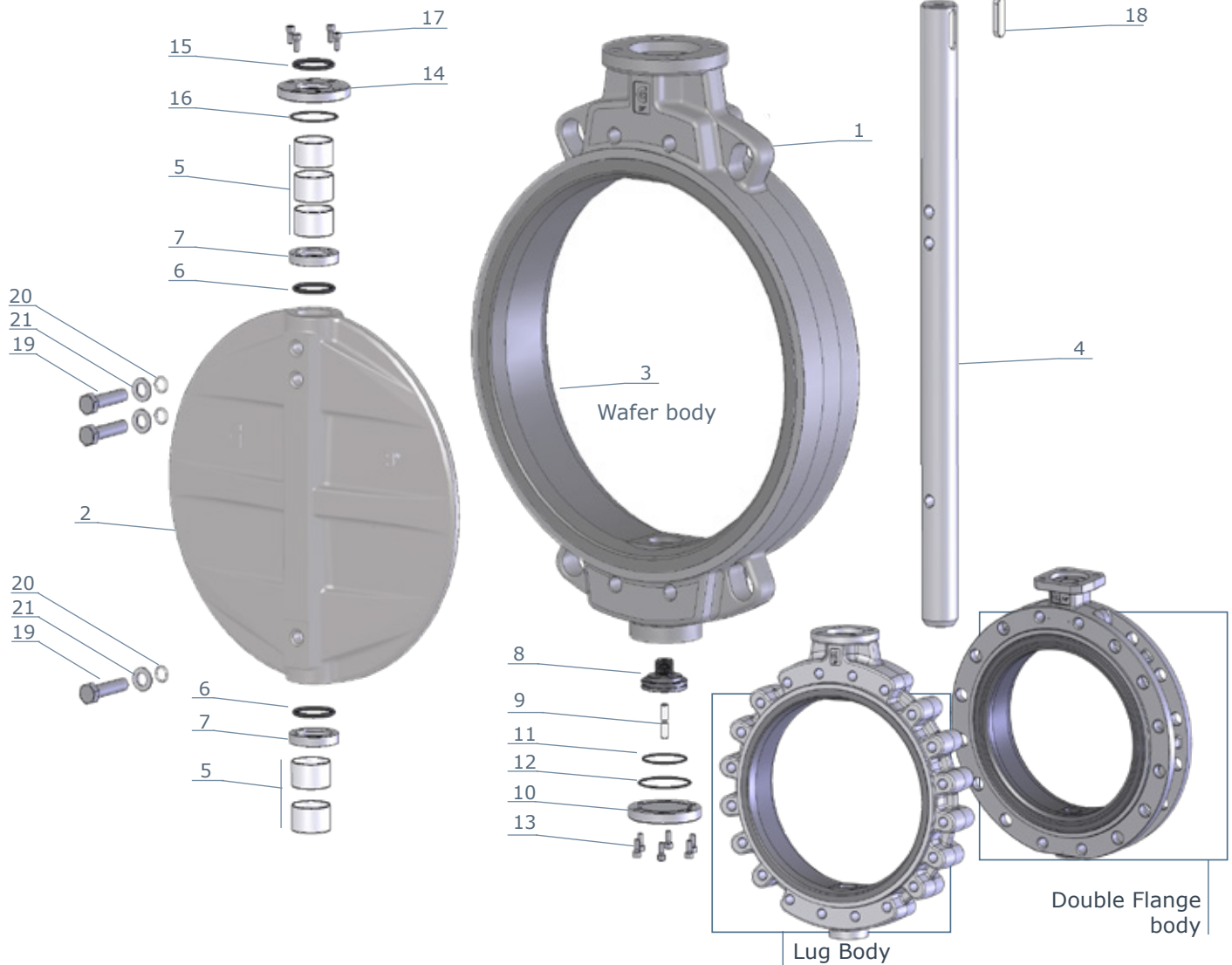

◇ parts included in spare kit

item	q.ty	part	material
1	1	body (BFKI only GS400)	<ul style="list-style-type: none"> <li>ductile iron GS400</li> <li>A216-WCB</li> <li>A352-LCB</li> <li>A351-CF8M (AISI 316)</li> <li>aluminium-bronze</li> </ul>
2	1	disc	<ul style="list-style-type: none"> <li>ductile iron GS400</li> <li>A351 - CF8M (AISI 316)</li> <li>aluminium-bronze</li> <li>Hastelloy®</li> <li>Monel®</li> </ul>
3	1	body seat (vulcanized not replaceable)	<ul style="list-style-type: none"> <li>NBR (BUNA®)</li> <li>EPDM</li> <li>EPDM HT</li> <li>FKM (VITON®)</li> </ul>
4	1	shaft	<ul style="list-style-type: none"> <li>AISI 303</li> <li>AISI 316 (on request)</li> </ul>
◇5	5	bush	steel + PTFE
◇6	2	shaft O-ring	<ul style="list-style-type: none"> <li>NBR (BUNA®)</li> <li>FKM (VITON®) on request</li> </ul>

item	q.ty	part	material
7	2	O-ring housing	AISI 316
8	1	shaft support	Bronze
9	2	adjusting screw	AISI 316
10	1	lower flange	zinc plated steel
◇11	1	O-ring	NBR (BUNA®)
◇12	1	O-ring	NBR (BUNA®)
13	6	screw	zinc plated steel
14	1	upper flange	zinc plated steel
◇15	1	O-ring	NBR (BUNA®)
◇16	1	O-ring	NBR (BUNA®)
17	4	screw	zinc plated steel
18	1	key	steel
19	3	screw	AISI 316
◇20	3	O-ring	PTFE
21	3	washer	AISI 316



**BVKA** - Wafer **BLKA** - Lug  
DN 40 - 800 • 1"1/2 - 32"

**BVKX** - Wafer  
DN 50 - 250 • 2" - 10"

**BLKX** - Lug  
DN 50 - 200 • 2" - 8"

**Max working pressure:**

BVKA/BLKA DN 40÷800: **20 Bar**  
Flange: **PN 10-16 • A150**  
BVKX DN 50÷250: **25 Bar**  
Flange: **PN 25 • A150**  
BLKX DN 50÷200: **25 Bar**  
Flange: **PN 25**

To be used also with vacuum

**Design:**

EN 593 ~ EN 736 ~ EN 12516 ~ EN 1092  
ISO 5211 ~ DIN 3337 ~ API 609  
PED 2014/68/EU - Mod. H

**Face to face:**

DIN EN 558-1 Series 20 ~ ISO 5752 Series 20  
BS-5155 Series 4 ~ MSS-SP67  
API609 cat.A ~ NFE 29305-1

**Testing:**

EN 12266-1 Rate A (supersedes DIN 3230)  
ISO 5208 Rate A ~ API 598

**Tag:**

EN 19 ~ MSS SP-25



**SIL** safety integrity level

**EAC**

**CE** 0497 [PED]



**Ex** II 2 GD c TX



All valves are supplied with a metallic label in compliance with PED directive.



BODY			BVKA/BLKA	BVKX	BLKX
material	references	standard coating	DN	DN	DN
Ductile iron	EN-GJS 400-15 (GS400)	Epoxy RAL 5009	40-800	50-250	50-200
Carbon steel	ASTM A216-WCB	Epoxy RAL 9005	40-800	50-100	50-100
Stainless steel	ASTM A351 CF8M (A316)	-	40-800	50-100	50-100
Aluminium-bronze	ASTM B148-C958.00	-	40-800	50-100	50-100

DISCO			BVKA/BLKA	BVKX	BLKX
material	references	standard coating	DN	DN	DN
Stainless steel	ASTM A351 CF8M (A316)	-	40-800	50-250	50-200
Aluminium-bronze	ASTM B148-C958.00	-	40-800	50-250	50-200
Hastelloy®	ASTM A494 CX2MW	-	40-800	50-250	50-200
Monel®	ASTM A494 M35-1	-	40-800	50-250	50-200

BODY RUBBER SEAT		KA DN 40/150 replaceable - DN 200/800 vulcanized not replaceable KX DN 50/250 vulcanized not replaceable		
ref.	designation	trade name	working temp.	applications
NBR	nitrile rubber	BUNA®	-25°C / +100°C	oils, hydrocarbons, gas, air, water
EPDM	copolymer EPDM	-	-35°C / +130°C	water, sea water, steam, diluted acids
EPDM HT	copolymer EPDM HT	-	-30°C / +135°C	water, sea water, steam, diluted acids
FKM	fluoroelastomer	VITON®	-20°C / +200°C	oils, acids, hydrocabons

On request can be supplied other materials as: LCB, Hastelloy, Monel, Uranus, Alloy, DUPLEX, Special steels, Special bronzes.  
Coating on request: RILSAN®, Halar®, Chenisil®



**BVKA** - Wafer **BLKA** - Lug  
 DN 40 - 150 • 11/2" - 6"  
 PN 10-16 • ANSI 150

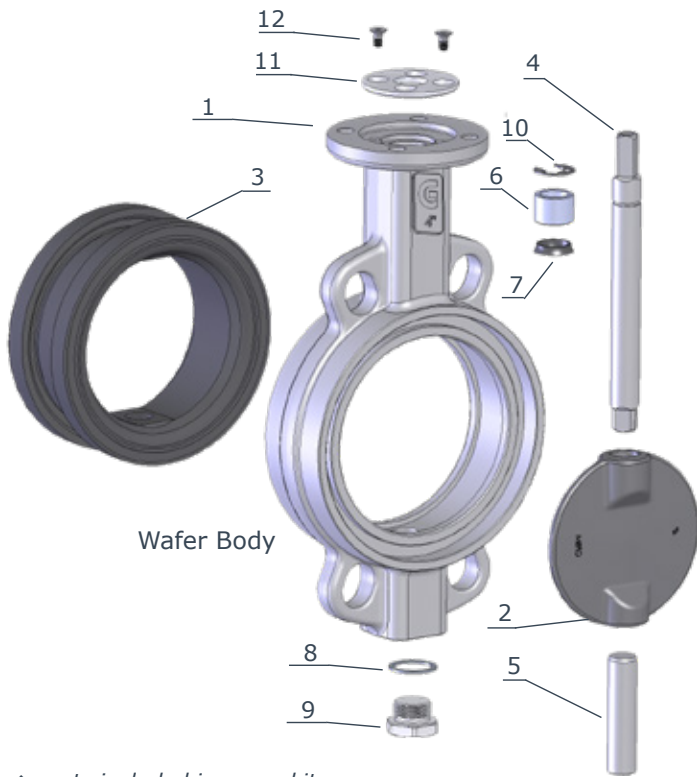

item	q.ty	part	material
1	1	body	<ul style="list-style-type: none"> <li>ductile iron GS400</li> <li>A216 - WCB</li> <li>A352 - LCB</li> <li>A351 - CF8M (AISI 316)</li> <li>aluminium-bronze</li> <li>Hastelloy®</li> <li>Monel®</li> </ul>
2	1	disc	<ul style="list-style-type: none"> <li>A351 - CF8M (AISI 316)</li> <li>aluminium-bronze</li> <li>Hastelloy®</li> <li>Monel®</li> </ul>
◇3	1	body seat (replaceable)	<ul style="list-style-type: none"> <li>NBR (BUNA®)</li> <li>EPDM</li> <li>EPDM HT</li> <li>FKM (VITON®)</li> </ul>
4	1	upper shaft	<ul style="list-style-type: none"> <li>AISI 430</li> <li>AISI 316 (on request)</li> </ul>
5	1	lower shaft	<ul style="list-style-type: none"> <li>AISI 430</li> <li>AISI 316 (on request)</li> </ul>
◇6	1	bush	bronze
◇7	1	shaft packing	<ul style="list-style-type: none"> <li>NBR (BUNA®)</li> <li>FKM (VITON®) (on request)</li> </ul>
8	1	plug packing	aluminium
9	1	threaded plug	zinc plated steel
10	1	stop ring	steel
11	1	upper flange	IXEF (DN 40-150)
12	2	screw	zinc plated steel

◇ parts included in spare kit

**BVKA** - Wafer **BLKA** - Lug  
 DN 200 - 300 • 8" - 12"  
 PN 10-16 • ANSI 150

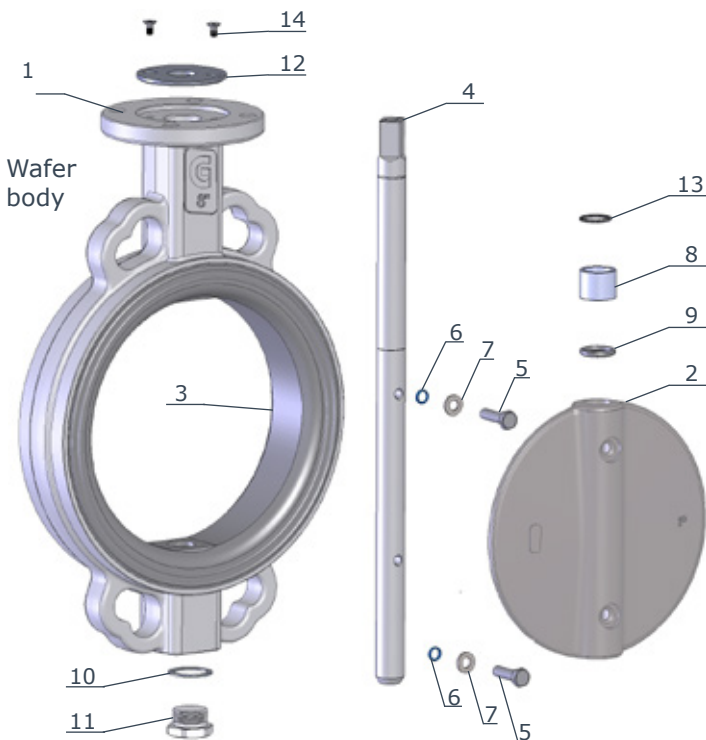

item	q.ty	part	material
1	1	body	<ul style="list-style-type: none"> <li>ductile iron GS400</li> <li>A216-WCB</li> <li>A352-LCB</li> <li>A351-CF8M (AISI 316)</li> <li>aluminium-bronze</li> </ul>
2	1	disc	<ul style="list-style-type: none"> <li>A351-CF8M (AISI 316)</li> <li>aluminium-bronze</li> <li>Hastelloy®</li> <li>Monel®</li> </ul>
3	1	body seat (vulcanized not replaceable)	<ul style="list-style-type: none"> <li>NBR (BUNA®)</li> <li>EPDM</li> <li>EPDM HT</li> <li>FKM (VITON®)</li> </ul>
4	1	shaft	<ul style="list-style-type: none"> <li>AISI 430</li> <li>AISI 316 (on request)</li> </ul>
5	2	screw	AISI 316
◇6	2	O.Ring	PTFE
7	2	washer	AISI 316
◇8	1	bush	bronze
◇9	1	shaft packing	<ul style="list-style-type: none"> <li>NBR (BUNA®)</li> <li>FKM (VITON®) (on req.)</li> </ul>
10	1	plug packing	aluminium
11	1	threaded plug	zinc plated steel
12	1	upper flange	aluminium
13	1	stop ring	steel
14	2	screw	zinc plated steel

◇ parts included in spare kit



**BVKA** - Wafer **BLKA** - Lug  
 DN 350 - 400 • 14" - 16"  
 PN 10-16 • ANSI 150

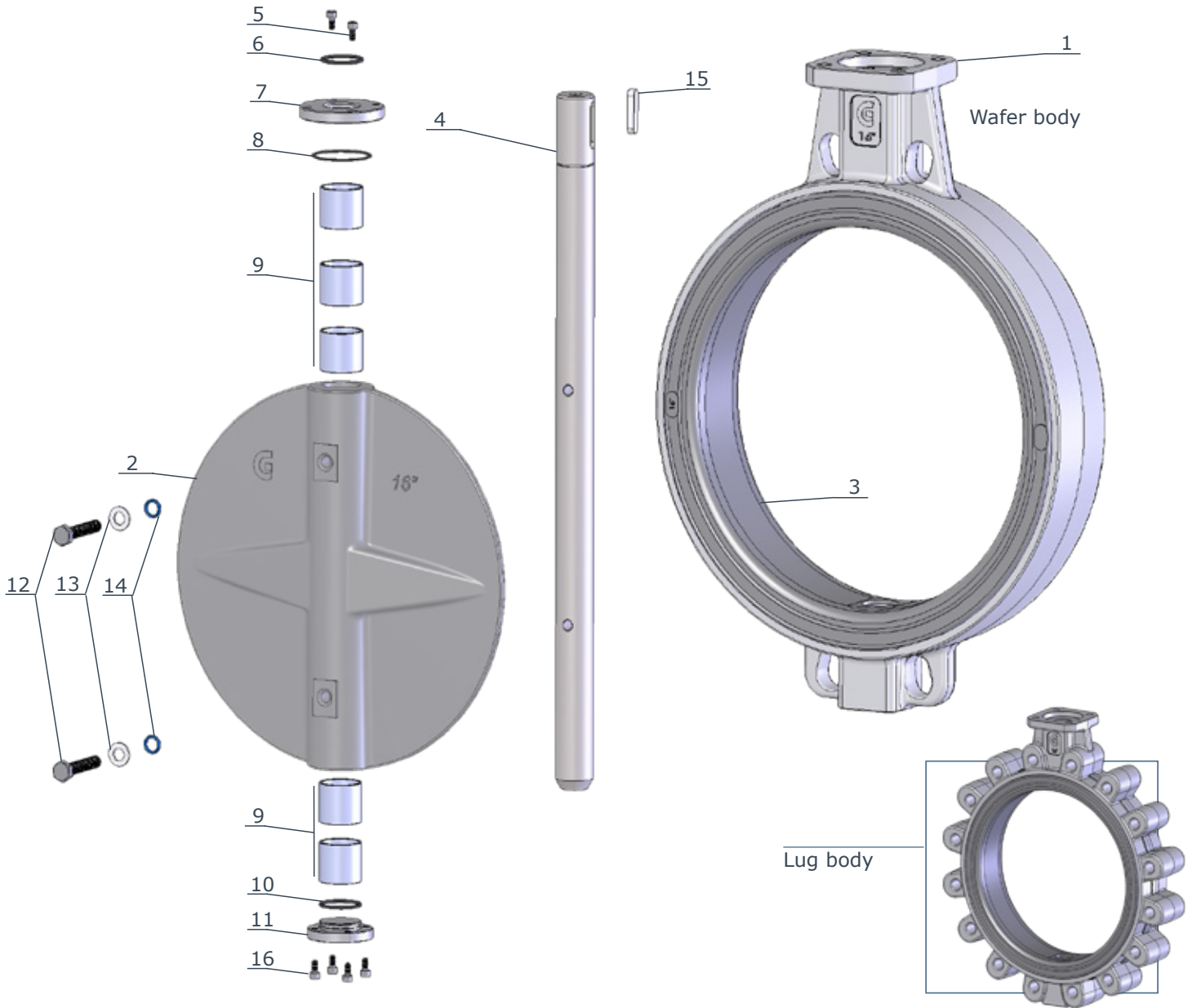

◇ parts included in spare kit

item	q.ty	part	material
1	1	body	<ul style="list-style-type: none"> <li>ductile iron GS400</li> <li>A216-WCB</li> <li>A352-LCB</li> <li>A351-CF8M (AISI 316)</li> <li>aluminium-bronze</li> </ul>
2	1	disc	<ul style="list-style-type: none"> <li>A351 - CF8M (AISI 316)</li> <li>aluminium-bronze</li> <li>Hastelloy®</li> <li>Monel®</li> </ul>
3	1	body seat (vulcanized not replaceable)	<ul style="list-style-type: none"> <li>NBR (BUNA®)</li> <li>EPDM</li> <li>EPDM HT</li> <li>FKM (VITON®)</li> </ul>
4	1	shaft	<ul style="list-style-type: none"> <li>AISI 430</li> <li>AISI 316 (on request)</li> </ul>

item	q.ty	part	material
5	2	screw	zinc plated steel
◇6	1	O.ring	NBR (BUNA®)
7	1	upper flange	zinc plated steel
◇8	1	O.ring	NBR (BUNA®)
◇9	5	bush	bronze
◇10	1	O.ring	NBR (BUNA®)
11	1	lower flange	zinc plated steel
12	2	screw	AISI 316
13	2	washer	AISI 316
◇14	2	O. ring	PTFE
15	1	key	steel C40
16	4	screw	zinc plated steel



**BVKA** - Wafer **BLKA** - Lug  
 DN 450 - 500 • 18" - 20"  
 PN 10-16 • ANSI 150

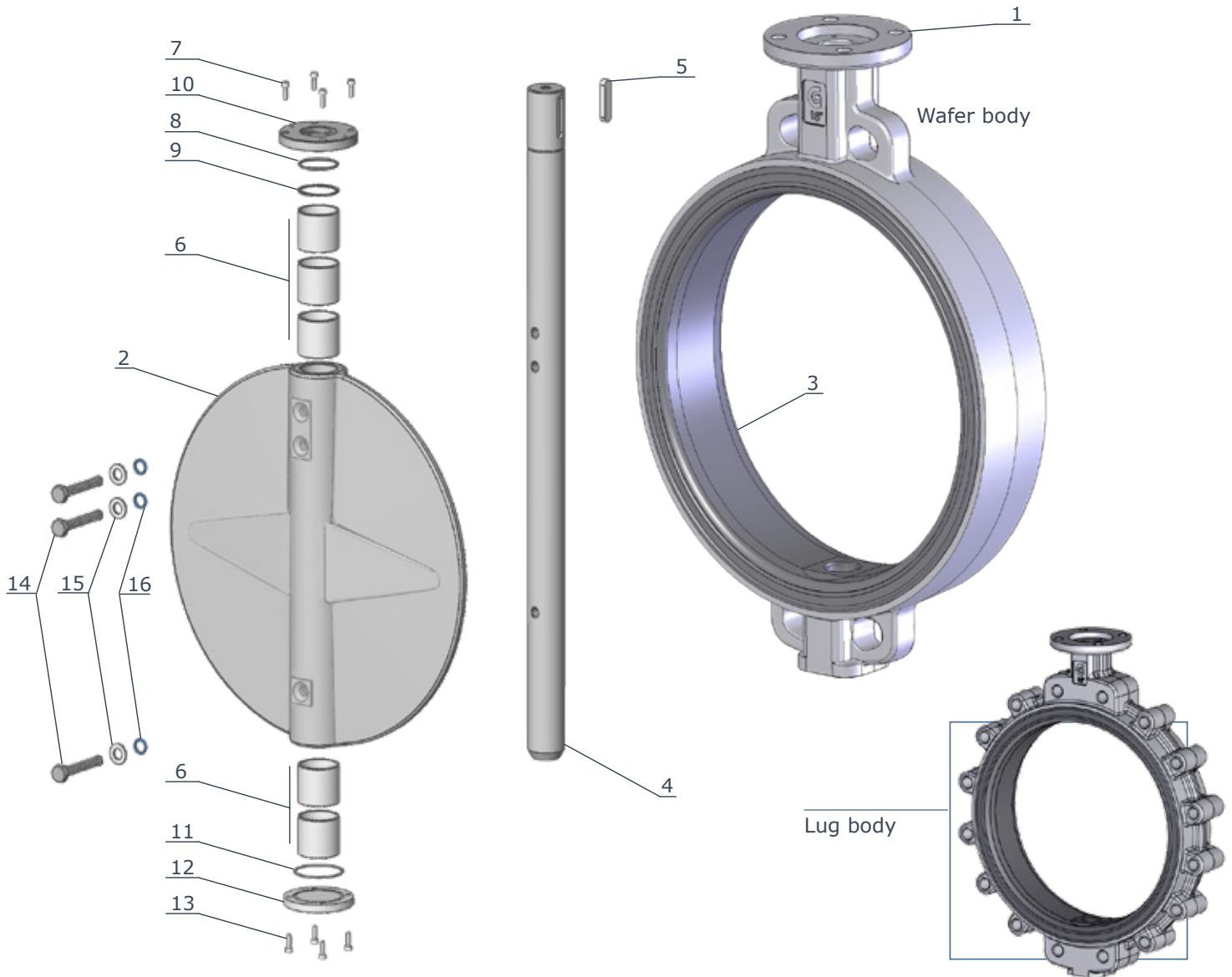

◇ parts included in spare kit

item	q.ty	part	material
1	1	body	<ul style="list-style-type: none"> <li>ductile iron GS400</li> <li>A216-WCB</li> <li>A352-LCB</li> <li>A351-CF8M (AISI 316)</li> <li>aluminium-bronze</li> </ul>
2	1	disc	<ul style="list-style-type: none"> <li>A351 - CF8M (AISI 316)</li> <li>aluminium-bronze</li> <li>Hastelloy®</li> <li>Monel®</li> </ul>
3	1	body seat (vulcanized not replaceable)	<ul style="list-style-type: none"> <li>NBR (BUNA®)</li> <li>EPDM</li> <li>EPDM HT</li> <li>FKM (VITON®)</li> </ul>
4	1	shaft	<ul style="list-style-type: none"> <li>AISI 430</li> <li>AISI 316 (on request)</li> </ul>
5	1	key	<ul style="list-style-type: none"> <li>steel C40</li> </ul>

item	q.ty	part	material
◇6	5	bush	<ul style="list-style-type: none"> <li>steel + PTFE</li> </ul>
7	4	screw	<ul style="list-style-type: none"> <li>zinc plated steel</li> </ul>
◇8	1	O.ring	<ul style="list-style-type: none"> <li>NBR (BUNA®)</li> </ul>
9	5	stop ring	<ul style="list-style-type: none"> <li>steel</li> </ul>
10	1	upper flange	<ul style="list-style-type: none"> <li>zinc plated steel</li> </ul>
◇11	1	O.ring	<ul style="list-style-type: none"> <li>NBR (BUNA®)</li> </ul>
12	1	lower flange	<ul style="list-style-type: none"> <li>zinc plated steel</li> </ul>
13	4	screw	<ul style="list-style-type: none"> <li>steel</li> </ul>
14	2	screw	<ul style="list-style-type: none"> <li>AISI 316</li> </ul>
15	2	washer	<ul style="list-style-type: none"> <li>AISI 316</li> </ul>
◇16	2	O. ring	<ul style="list-style-type: none"> <li>PTFE</li> </ul>

**BVKA** - Wafer **BLKA** - Lug  
**DN 600 - 800 • 24" - 32"**  
**PN 16 • ANSI 150**

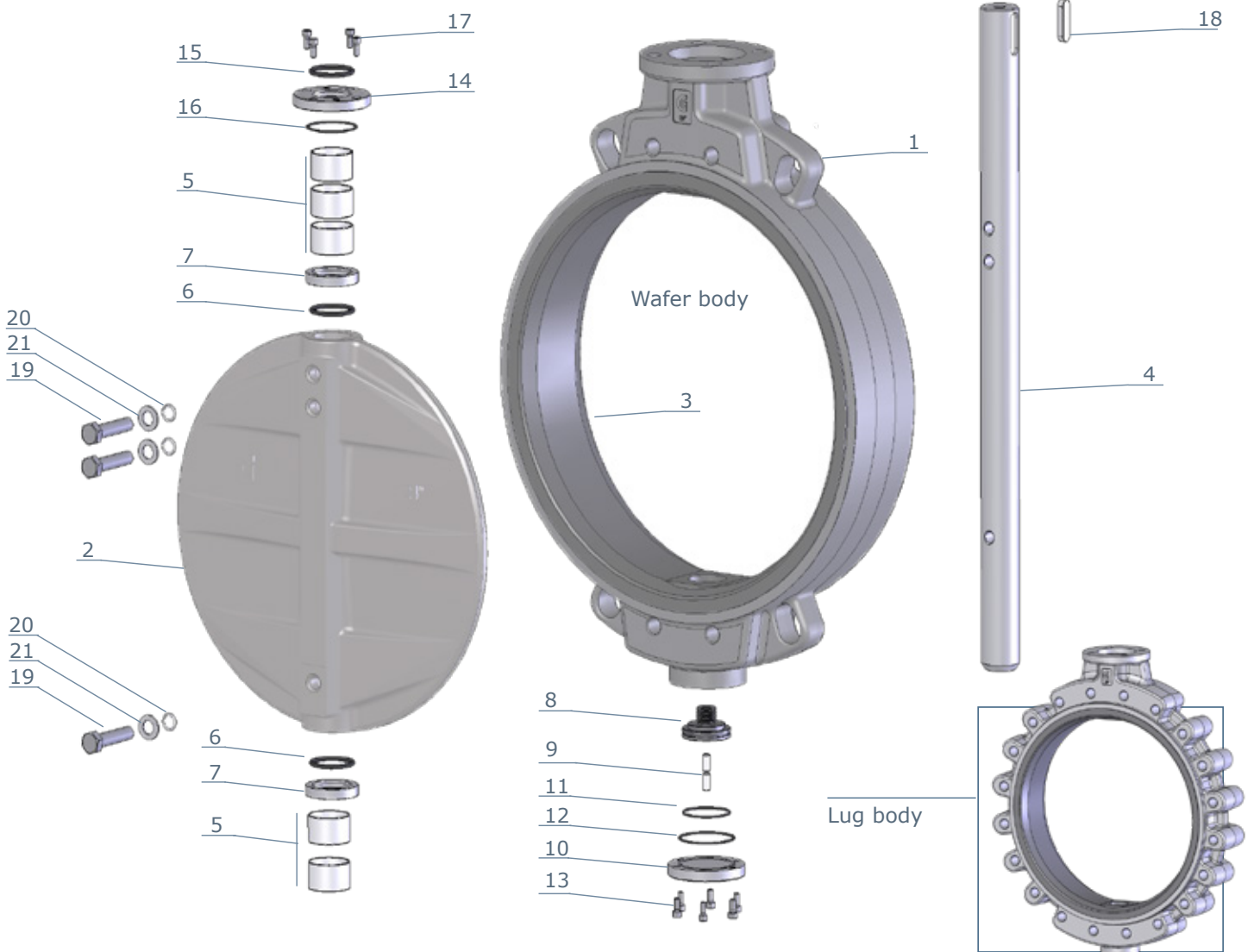

◇ parts included in spare kit

item	q.ty	part	material
1	1	body	<ul style="list-style-type: none"> <li>ductile iron GS400</li> <li>A216-WCB</li> <li>A352-LCB</li> <li>A351-CF8M (AISI 316)</li> <li>aluminium-bronze</li> </ul>
2	1	disc	<ul style="list-style-type: none"> <li>ductile iron GS400</li> <li>A351 - CF8M (AISI 316)</li> <li>aluminium-bronze</li> <li>Hastelloy®</li> <li>Monel®</li> </ul>
3	1	body seat (vulcanized not replaceable)	<ul style="list-style-type: none"> <li>NBR (BUNA®)</li> <li>EPDM</li> <li>EPDM HT</li> <li>FKM (VITON®)</li> </ul>
4	1	shaft	<ul style="list-style-type: none"> <li>AISI 303</li> <li>AISI 316 (on request)</li> </ul>
◇5	5	bush	<ul style="list-style-type: none"> <li>steel + PTFE</li> </ul>
◇6	2	O.ring	<ul style="list-style-type: none"> <li>NBR (BUNA®)</li> <li>FKM (VITON®) on request</li> </ul>

item	q.ty	part	material
7	2	O.ring housing	<ul style="list-style-type: none"> <li>AISI 316</li> </ul>
8	1	shaft support	<ul style="list-style-type: none"> <li>Bronze</li> </ul>
9	2	adjusting screw	<ul style="list-style-type: none"> <li>AISI 316</li> </ul>
10	1	lower flange	<ul style="list-style-type: none"> <li>zinc plated steel</li> </ul>
◇11	1	O.ring	<ul style="list-style-type: none"> <li>NBR (BUNA®)</li> </ul>
◇12	1	O.ring	<ul style="list-style-type: none"> <li>NBR (BUNA®)</li> </ul>
13	6	screw	<ul style="list-style-type: none"> <li>zinc plated steel</li> </ul>
14	1	upper flange	<ul style="list-style-type: none"> <li>zinc plated steel</li> </ul>
◇15	1	O.ring	<ul style="list-style-type: none"> <li>NBR (BUNA®)</li> </ul>
◇16	1	O.ring	<ul style="list-style-type: none"> <li>NBR (BUNA®)</li> </ul>
17	4	screw	<ul style="list-style-type: none"> <li>zinc plated steel</li> </ul>
18	1	key	<ul style="list-style-type: none"> <li>steel</li> </ul>
19	3	screw	<ul style="list-style-type: none"> <li>AISI 316</li> </ul>
◇20	3	O.ring	<ul style="list-style-type: none"> <li>PTFE</li> </ul>
21	3	washer	<ul style="list-style-type: none"> <li>AISI 316</li> </ul>



**BVKX - Wafer BLKX - Lug**  
**DN 50 - 100 • 2" - 4"**  
**PN 25**

item	q.ty	part	material
1	1	body	<ul style="list-style-type: none"> <li>ductile iron GS400</li> <li>A216 - WCB</li> <li>A352 - LCB</li> <li>A351 - CF8M (AISI 316)</li> </ul>
2	1	disc	<ul style="list-style-type: none"> <li>A351 - CF8M (AISI 316)</li> <li>aluminium-bronze</li> <li>Hastelloy®</li> <li>Monel®</li> </ul>
3	1	body seat (vulcanized not replaceable)	<ul style="list-style-type: none"> <li>NBR (BUNA®)</li> <li>EPDM</li> <li>EPDM HT</li> <li>FKM (VITON®)</li> </ul>
4	1	upper shaft	<ul style="list-style-type: none"> <li>AISI 430</li> <li>AISI 316 (on request)</li> </ul>
5	1	lower shaft	<ul style="list-style-type: none"> <li>AISI 430</li> <li>AISI 316 (on request)</li> </ul>
◇6	1	bush	bronze
◇7	1	shaft packing	<ul style="list-style-type: none"> <li>NBR (BUNA®)</li> <li>FKM (VITON®) on req.</li> </ul>
8	1	plug packing	aluminium
9	1	threaded plug	zinc plated steel
10	1	stop ring	steel
11	1	upper flange	IXEF (DN 50-100)
12	2	screw	zinc plated steel
◇13	2	upper bush	steel + PTFE
◇14	2	lower bush	steel + PTFE

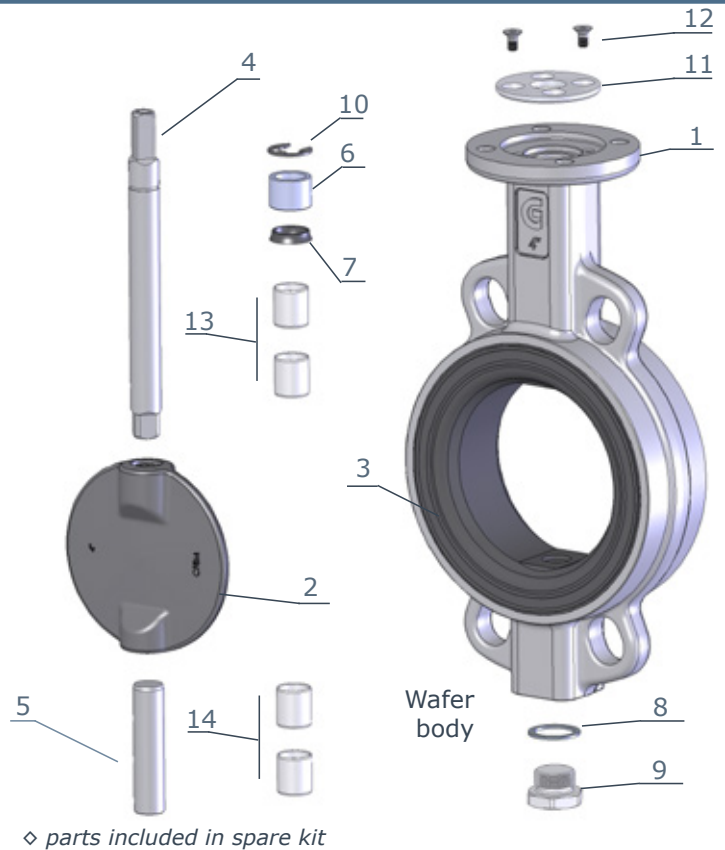

**BVKX - Wafer**  
**DN 125 - 250 • 5" - 10"**  
**PN 25**

item	q.ty	part	material
1	1	body	<ul style="list-style-type: none"> <li>ductile iron GS400</li> </ul>
2	1	disc	<ul style="list-style-type: none"> <li>A351-CF8M (AISI 316)</li> <li>aluminium-bronze</li> <li>Hastelloy®</li> <li>Monel®</li> </ul>
3	1	body seat (vulcanized not replaceable)	<ul style="list-style-type: none"> <li>NBR (BUNA®)</li> <li>EPDM</li> <li>EPDM HT</li> <li>FKM (VITON®)</li> </ul>
4	1	shaft	<ul style="list-style-type: none"> <li>AISI 430</li> <li>AISI 316 (on request)</li> </ul>
5	2	screw	AISI 316
◇6	2	O.Ring	PTFE
7	2	washer	AISI 316
◇8	1	bush	bronze
◇9	1	shaft packing	<ul style="list-style-type: none"> <li>NBR (BUNA®)</li> <li>FKM (VITON®) (on req.)</li> </ul>
10	1	plug packing	aluminium
11	1	threaded plug	zinc plated steel
12	1	upper flange	<ul style="list-style-type: none"> <li>IXEF (DN 125-150)</li> <li>aluminium (DN 200-250)</li> </ul>
13	1	stop ring	steel
14	2	screw	zinc plated steel
◇15	2	upper bush	steel + PTFE
◇16	2	lower bush	steel + PTFE

**BLKX - Lug**  
**DN 125 - 200 • 5" - 8"**  
**PN 25**

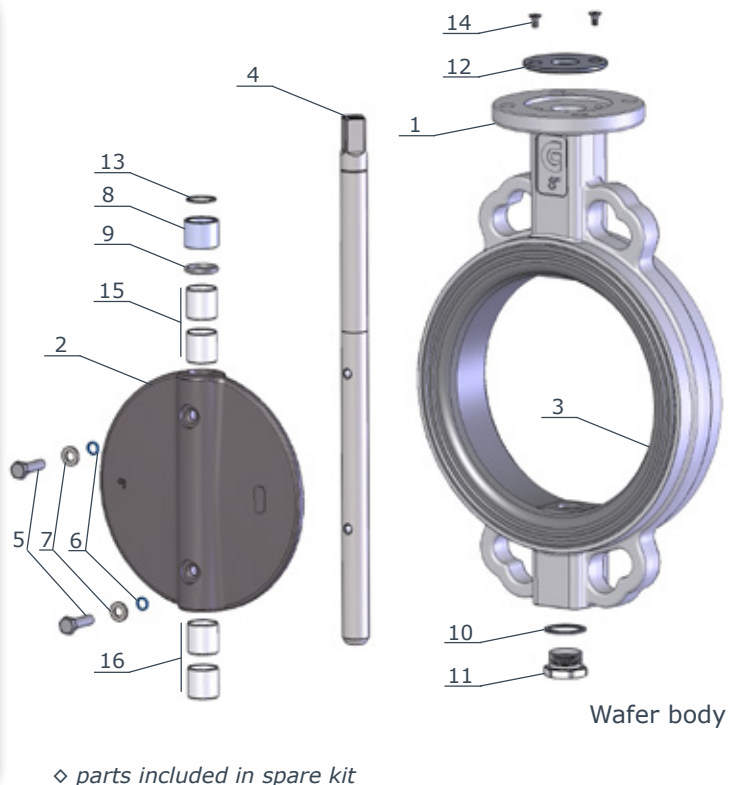



### BVPD - Wafer BLPD - Lug

### BVKI - Wafer BLKI - Lug

### BVKA - Wafer BLKA - Lug

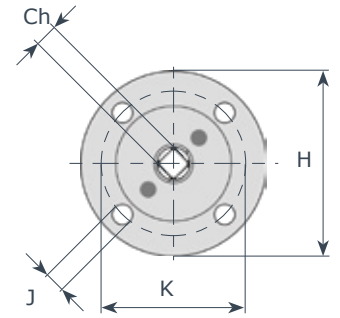
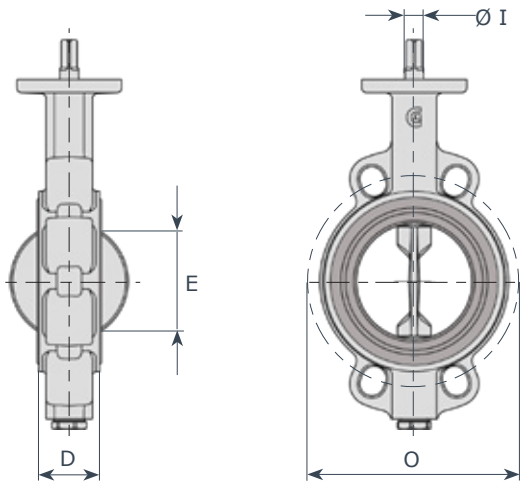
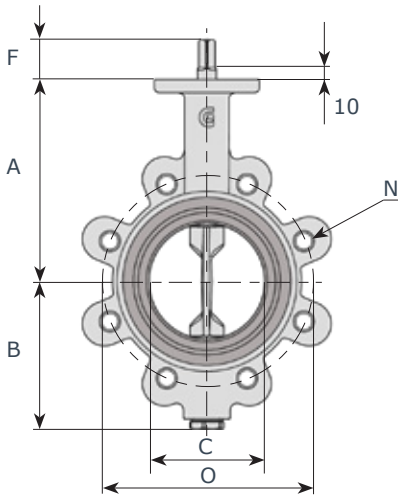

Upper flange - ISO 5211			
DN 40 - 150	F07 - 4 holes		
DN 200 - 300	F10 - 4 holes		

Note: in case of ANSI150 flanges, threading can be: 1 1/2" ÷ 12" ANSI B1.1UNC2B

DN	A	B	C	D	E	F	Ø I	Ch	H	K	J	Kg															
												PN 6			PN 10			PN 16			ANSI 150			PD-KI		KA	
												N	n.	O	N	n.	O	N	n.	O	N	n.	O	W	L	W	L
40	130	75	49	33	36	34	14	11	90	70	9	-	-	-	M16	4	110	M16	4	110	M14	4	98.4	2.2	3	2.2	3
50	138	81	55	43	35	34	14	11	90	70	9	M12	4	110	M16	4	125	M16	4	125	M16	4	120.7	2.8	3.7	2.8	3.7
65	144	98	68	46	50	34	14	11	90	70	9	M12	4	130	M16	8	145	M16	8	145	M16	4	139.7	3.7	5.3	3.7	5.3
80	158	110	81	46	67	34	14	11	90	70	9	M16	4	150	M16	8	160	M16	8	160	M16	4	152.4	4	6.1	4	6.1
100	173	128	101	52	87	34	16	11	90	70	9	M16	4	170	M16	8	180	M16	8	180	M16	8	190.5	6	8.1	6	8.1
125	186	140	126	56	113	34	18	14	90	70	9	M16	8	200	M16	8	210	M16	8	210	M20	8	215.9	7.2	9.7	7.2	9.7
150	202	155	150	56	140	34	18	14	90	70	9	M16	8	225	M20	8	240	M20	8	240	M20	8	241.3	9.1	11.5	9.5	11.8
200	240	190	200	60	191	38	22	17	125	102	11	M16	8	280	M20	8	295	M20	12	295	M20	8	298.5	14	27	16	29
250	270	220	250	68	241	38	30	22	125	102	11	M16	12	335	M20	12	350	M24	12	355	M22	12	362.0	22	34	26	38
300	300	247	298	78	289	38	30	22	125	102	11	M20	12	395	M20	12	400	M24	12	410	M22	12	431.8	32	49	36	53

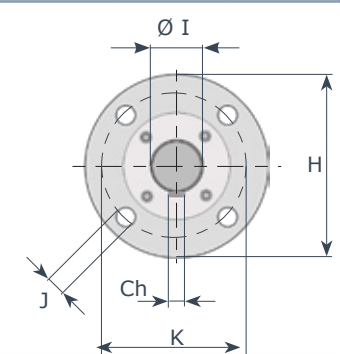
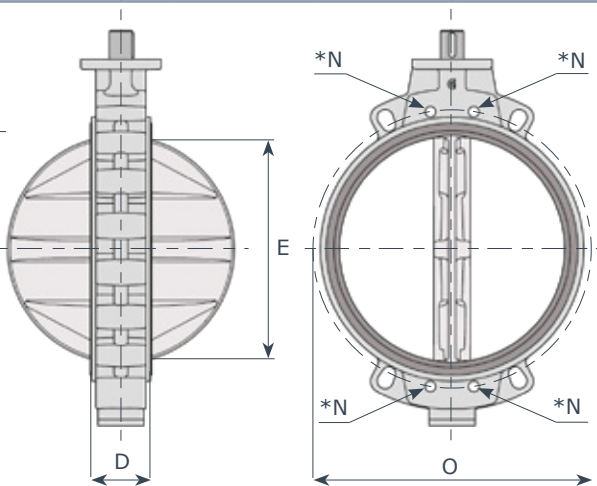
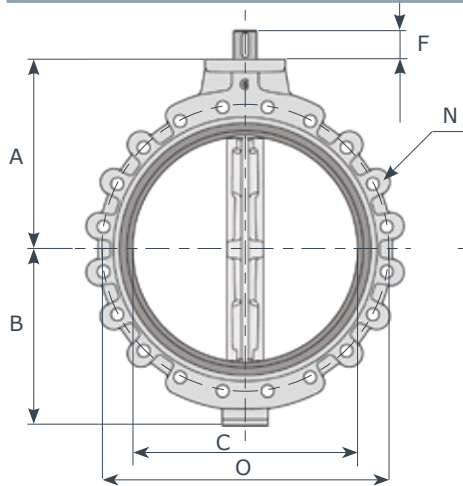

Upper flange - ISO 5211			
DN 350 - 400	F12 - 4 holes		
DN 450	F14 - 4 holes		
DN 500 - 600	F16 - 4 holes		
DN 700 - 800	F25 - 8 holes		

Note: in case of ANSI150 flanges, threading can be:  
14" ANSI B1.1UNC2B  
16" ÷ 32" ANSI B1.1-8 UNC2B

\*Note: WAFER bodies DN 600 - 700 - 800 have 4 holes N threaded as relevant LUG version

DN	A	B	C	D	E	F	Ø I	Ch	H	K	J	Kg															
												PN 6			PN 10			PN 16			ANSI 150			PD-KI		KA	
												N	n.	O	N	n.	O	N	n.	O	N	n.	O	W	L	W	L
350	330	280	341	78	332	60	35	10	150	125	14	M20	12	445	M20	16	460	M24	16	470	M24	12	476.3	42	62	55	75
400	355	305	390	102	376	60	40	12	150	125	14	M20	16	495	M24	16	515	M27	16	525	M27	16	539.8	76	90	94	104
450	400	343	444	114	430	60	45	12	175	140	18	M20	16	550	M24	20	565	M27	20	585	M27	16	577.8	110	170	135	195
500	422	366	495	127	479	60	45	12	210	165	22	M20	20	600	M24	20	620	M30	20	650	M27	20	635.0	140	180	165	205
600	495	460	595	154	575	75	60	18	210	165	22	M24	20	705	M27	20	725	M33	20	770	M33	20	749.3	220	290	220	290
700	550	506	690	165	670	90	70	20	300	254	18	M24	24	810	M27	24	840	M33	24	840	M33	28	863.6	300	415	300	415
800	640	590	780	190	757	100	80	22	300	254	18	M27	24	920	M30	24	950	M36	24	950	M39	28	977.9	444	570	465	570



### BFKI - Double Flange

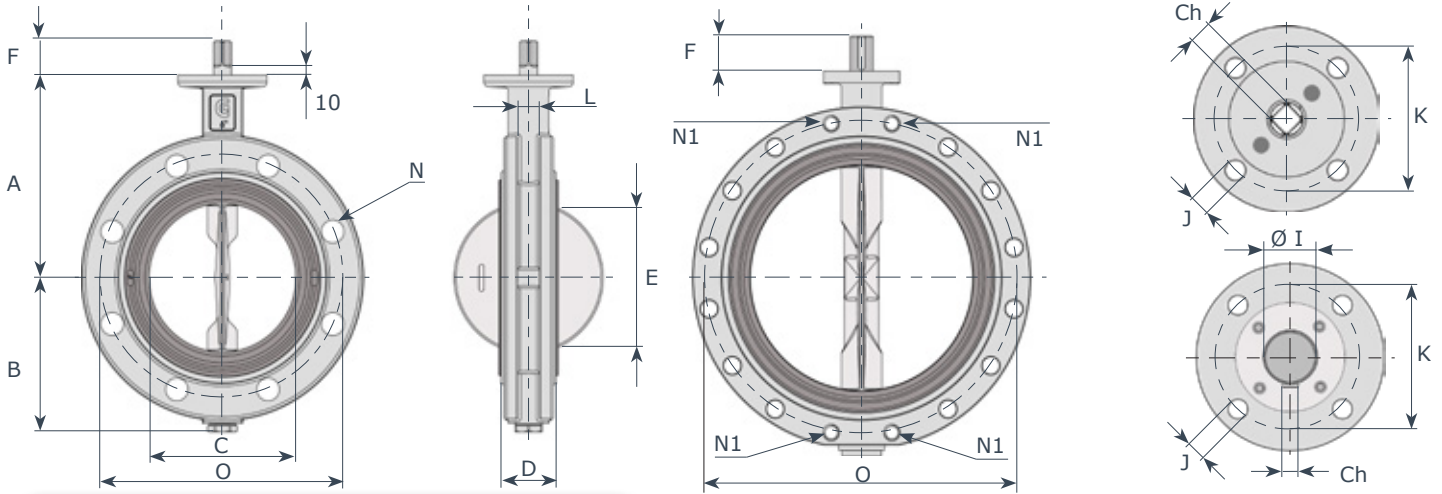

#### Upper flange - ISO 5211

DN 80 - 150	F07 - 4 holes	DN 350 - 400	F12 - 4 holes
DN 200 - 300	F10 - 4 holes	DN 450	F14 - 4 holes
		DN 500 - 600	F16 - 4 holes

Note: in case of ANSI150 flanges, threading can be 16"±24" ANSI B1.1-8 UNC2B

DN	"	A	B	C	D	E	F	Ø I	Ch	K	J	L	PN 6				PN 10				PN 16				ANSI 150				Kg.
													N	N1	n.	O	N	N1	n.	O	N	N1	n.	O	N	N1	n.	O	
80	3	158	110	81	46	67	34	14	11	70	9	14	18	--	4	150	18	--	8	160	18	--	8	160	18	--	4	152.4	6.5
100	4	173	128	101	52	87	34	16	11	70	9	16	18	--	4	170	18	--	8	180	18	--	8	180	18	--	8	190.5	8
150	6	202	155	150	56	140	34	18	14	70	9	18	18	--	8	225	22	--	8	240	22	--	8	240	22	--	8	241.3	12
200	8	240	190	200	60	191	38	22	17	102	11	22	18	--	8	280	22	--	8	295	22	--	12	295	22	--	8	298.4	20
250	10	270	220	250	68	241	38	30	22	102	11	30	18	--	12	335	22	--	12	350	25	--	12	355	25	--	12	361.9	30
300	12	300	247	298	78	289	38	30	22	102	11	30	22	M20	12	395	22	M20	12	400	28	M24	12	410	25	--	12	431.8	46
350	14	330	285	341	78	332	60	35	10	125	14	35	22	--	12	445	22	--	16	460	28	--	16	470	28	--	12	476.2	65
400	16	355	310	390	102	376	60	40	12	125	14	40	22	M20	16	495	25	M24	16	515	30	M27	16	525	30	M27	16	539.7	85
450	18	400	343	444	114	430	60	45	12	140	18	45	22	M20	16	550	25	M24	20	565	30	M27	20	585	30	M27	16	577.8	120
500	20	422	375	495	127	479	60	45	12	165	22	45	22	M20	20	600	25	M24	20	620	33	M30	20	650	30	M27	20	635.0	180
600	24	495	460	595	154	575	75	60	18	165	22	60	25	M24	20	705	30	M27	20	725	36	M33	20	770	36	M33	20	749.3	270

### BVKX - Wafer BLKX - Lug

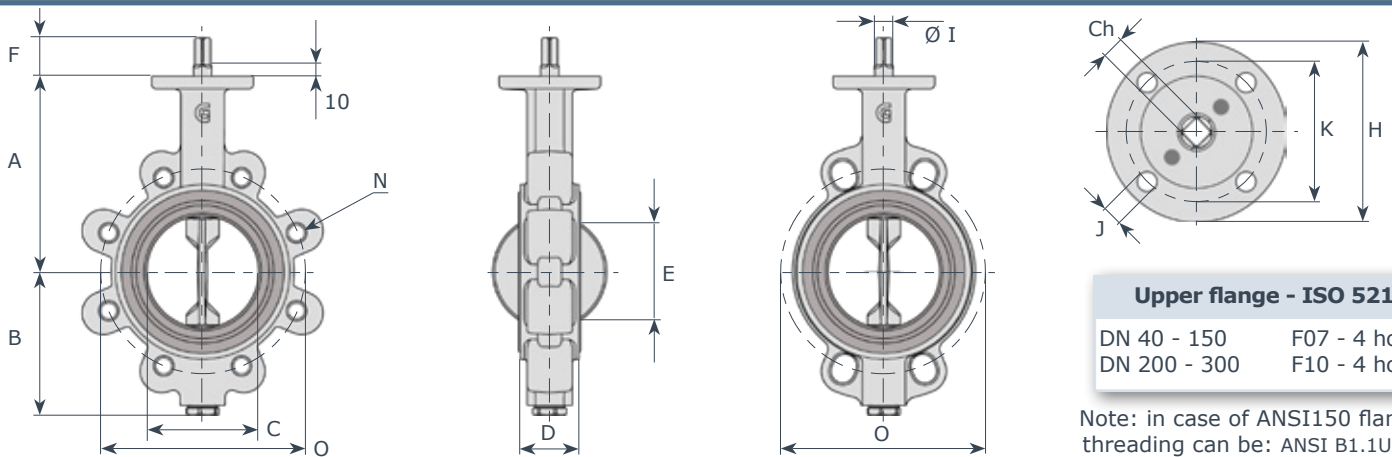

#### Upper flange - ISO 5211

DN 40 - 150	F07 - 4 holes
DN 200 - 300	F10 - 4 holes

Note: in case of ANSI150 flanges, threading can be: ANSI B1.1UNC2B

DN	"	A	B	C	D	E	F	Ø I	Ch	H	K	J	PN 25			Kg.	
													N	n.	O	wafer	lug
50	2	138	81	55	43	35	34	14	11	90	70	9	M16	4	125	2.8	3.7
65	2 <sup>1/2</sup>	144	98	68	46	50	34	14	11	90	70	9	M16	8	145	3.7	5.3
80	3	158	110	81	46	67	34	14	11	90	70	9	M16	8	160	4	6.1
100	4	173	128	101	52	87	34	16	11	90	70	9	M20	8	190	6	8.1
125	5	186	140	126	56	113	34	18	14	90	70	9	M24	8	220	7.2	9.7
150	6	202	155	150	56	140	34	18	14	90	70	9	M24	8	250	9.5	11.8
200	8	240	190	200	60	191	38	22	17	125	102	11	M24	12	310	16	29
250	10	270	220	250	68	241	38	30	22	125	102	11	--	--	370	25	--



### PD Series - Torque values - Nm - safety factor excluded

Seat body NBR/EPDM				fluid H <sub>2</sub> O - 20°C			
working pressure BAR							
DN	0	6	10	DN	0	6	10
80	5	7	11	200	47	58	90
100	8	12	24	250	89	100	115
125	22	31	40	300	167	180	280
150	40	45	49	350	245	340	395

Seat body FKM/natural rubber				fluid H <sub>2</sub> O - 20°C			
working pressure BAR							
DN	0	6	DN	0	6	DN	0
80	7	11	200	62	78	400	515
100	11	16	250	120	134	450	578
125	29	42	300	225	241	500	607
150	52	65	350	465	495	600	1795

### KI Series - Torque values - Nm - safety factor excluded

Seat body NBR/EPDM					fluid H <sub>2</sub> O - 20°C				
working pressure BAR					working pressure BAR				
DN	0	6	10	16	DN	0	6	10	16
40	11	11	13	14	150	55	60	84	90
50	11	12	13	15	200	100	107	180	210
65	11	16	16	18	250	160	175	220	320
80	20	30	36	40	300	260	270	320	390
100	40	43	45	48	350	410	450	590	850
125	48	52	52	70	400	450	480	650	900

Seat body FKM/natural rubber					fluid H <sub>2</sub> O - 20°C				
working pressure BAR					working pressure BAR				
DN	0	6	10	16	DN	0	6	10	16
40	14	14	16	17	150	66	72	101	108
50	14	15	16	18	200	120	129	216	252
65	14	20	20	22	250	192	210	264	386
80	24	36	44	48	300	312	330	396	480
100	48	52	54	58	350	498	545	728	1050
125	60	62	64	84	400	550	584	798	1120

### KA/KX Series - Torque values - Nm - safety factor excluded

Seat body NBR/EPDM							fluid H <sub>2</sub> O - 20°C				
working pressure BAR							working pressure BAR				
DN	0	6	10	16	20	25	DN	0	6	10	16
40	12	12	14	15	15	-	300	272	294	362	410
50	12	13	14	16	17	20	350	431	557	714	1071
65	12	17	17	19	20	31	400	683	767	893	1470
80	21	32	38	42	44	49	450	1000	1208	1313	1995
100	42	45	47	50	53	65	500	1155	1418	1733	2625
125	50	55	55	74	77	82	600	2300	2800	3700	4800
150	58	63	88	95	99	103	700	3800	5050	5600	6900
200	105	112	189	221	231	320	800	5200	6800	7900	10300
250	175	190	231	336	352	440					



### Head losses

NOTES: values indicated in this page is only for information

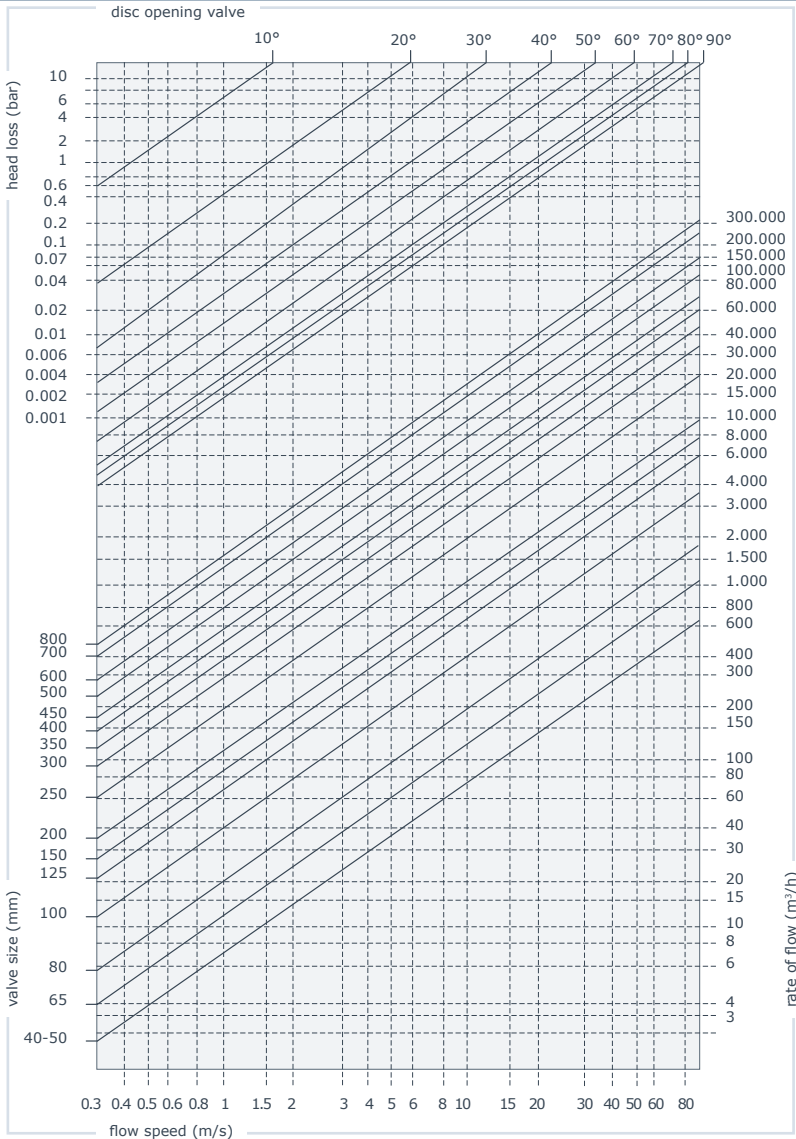

### Formulae for calculation of rate flow

**Liquids:** 
$$Q = \frac{KV}{\sqrt{\frac{PS}{\Delta P}}}$$

Q rate of flow (m<sup>3</sup>/h)  
 PS specific gravity (water=1)  
 ΔP pressure drop (bar)

**Gas:** 
$$Q = 28.5 \frac{KV}{\sqrt{\frac{PS}{P_2 \cdot \Delta P}}}$$

Q rate of flow (m<sup>3</sup>/h)  
 PS specific gravity (air=1)  
 ΔP pressure drop (bar) (less than 1/2 inlet pressure)  
 P<sub>2</sub> outlet pressure

**Steam:** 
$$Q = 22.5 \cdot KV \cdot \sqrt{P_2 \cdot \Delta P}$$

Q rate of flow (Kg/h)  
 ΔP pressure drop (bar) (less than 1/2 inlet pressure)  
 P<sub>2</sub> outlet pressure

### Calculation of the rate of flow equivalent to H2O

$$Q_e = Q \sqrt{\frac{d}{1000}}$$

For different liquid, gas or steam head losses are determined by equivalent water of flow, as follows:

Q<sub>e</sub> equivalent water flow (mc/l o l/s)  
 Q fluid flow (mc/l o l/s)  
 d fluid specific gravity (Kg/mc)

### Values KV (CV = 1,16 KV)

angle	40/50	65	80	100	125	150	200	250	300	350	400	450	500	600	700	800
5°	-	-	-	-	-	-	-	-	-	53	68	85	106	151	206	270
10°	-	-	-	-	-	-	-	21	49	123	161	199	246	354	482	629
15°	0,2	0,6	1,8	2,4	4,2	5,6	14	80	188	228	299	369	457	658	900	1168
20°	0,9	2,5	5,2	9,5	15	23	110	156	280	315	412	511	630	907	1234	2010
25°	3	6,1	12	22	38	61	125	225	354	457	597	740	914	1314	1789	2735
30°	6,1	11	21	39	69	112	211	310	381	661	863	1069	1320	1899	2585	5080
35°	9,9	18	33	60	105	166	303	433	521	890	1162	1440	1778	2560	3484	6254
40°	15	27	49	88	148	228	405	591	742	1184	1547	1916	2366	3407	4638	9700
45°	21	38	68	121	199	303	528	774	987	1552	2028	2512	3102	4466	6079	11581
50°	29	51	91	159	262	394	679	988	1252	2008	2620	3248	4010	5774	7860	15000
55°	39	68	119	207	338	505	863	1247	1571	2548	3318	4123	5090	7329	9976	17765
60°	53	90	156	269	434	641	1085	1591	2059	3225	4202	5218	6442	9277	12627	22200
65°	72	121	209	357	565	820	1364	2065	2807	3983	5196	6445	7957	11457	15595	26077
70°	92	161	283	487	768	1097	1788	2715	3744	5195	6775	8412	10377	14944	20341	34500
75°	109	209	381	662	1059	1507	2425	3625	4935	6964	9084	11269	13912	20032	27267	39546
80°	115	240	457	815	1303	1861	3043	4768	6831	9301	12142	15048	18578	26752	36413	47560
85°	115	253	502	906	1457	2008	3642	4890	8230	10280	13408	16632	20533	29568	40246	52566
90°	116	257	508	925	1492	2168	3838	5010	9233	10792	14082	17840	22024	31715	43166	56381



### Flanges to be used

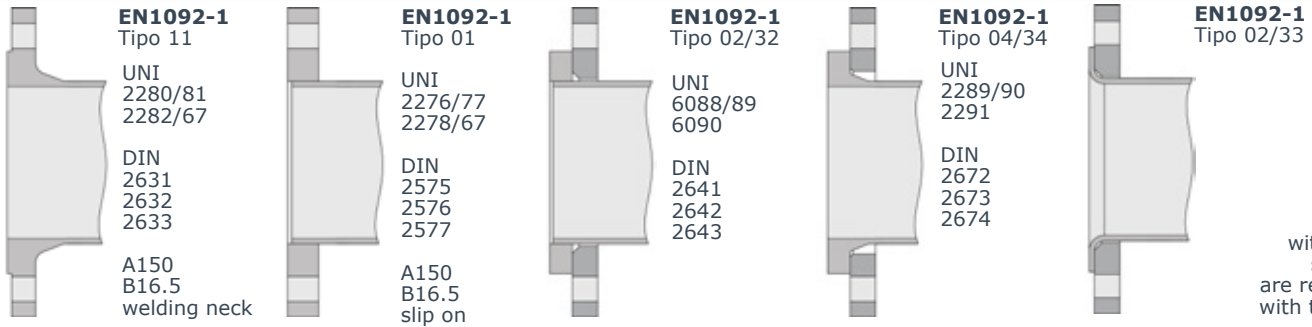

**NOTE**  
only valves with vulcanized seat (KA/KX) are recommended with these flanges

### Compatibility flanges - body Wafer

DN	EN 1092-1 / EN 1092-2					ASME/ANSI			BS 10		JIS B2220		
	PN 6	PN 10	PN 16	PN 25	PN 40	class 125	class 150	class 300	tab D	tab E	5K	10K	16K
40	☐	✓	✓	✓	✓	✓	✓	●	✓	✓	✓	✓	✓
50	☐	✓	✓	✓	✓	✓	✓	✗	●	●	●	☐	✗
65	☐	✓	✓	✓	✓	✓	✓	●	●	●	✓	✓	☐
80	☐	✓	✓	✓	✓	✓	✓	●	●	●	●	●	✓
100	☐	✓	✓	●	●	✓	✓	✗	●	✓	✗	●	✓
125	☐	✓	✓	●(1)	●(1)	✓	✓	✗	✓	✓	☐	✓	●(1)
150	☐	✓	✓	●(1)	●(1)	✓	✓	✗	●	●	☐	✓	✗
200	☐	✓	✓	✓(2)	✗	✓	✓	✗	✓	✓	●	●	✓(2)
250	☐	✓	✓	●	✗	✓	✓	✗	✗	✓	●	✓	✗
300	☐	✓	✓	✓(2)	✗	✓	✓	✗	✓	✓	●	●	✓(2)
350	☐	✓	✓	●	✗	✓	✓	✗	✓	✓	●	●	●
400	☐	✓	✓	●	✗	✓	✓	✗	✗	✗	●	●	✓
450	☐	✓	✓	●	✗	✓	✓	✗	✗	●	●	✓	✗
500	☐	✓	✓	●	✗	✓	✓	✗	✗	✗	●	✓	✓
600	☐	✓	✓	●	✗	✓	✓	✗	✗	✗	●	✗	✗
700	☐	✓	✓	✗	✗		✓	✗			●	✓	✗
800	☐	✓	✓	✗	✗		✓	✗			●	✓	✗

✓ standard on request    ☐ only body PN 6 version not possible    ● on request    ✗ not possible  
 (1) only with ductile iron bodies  
 (2) standard with ductile iron and steel bodies, on request with different materials

### Compatibility flanges - body Lug

DN	EN 1092-1 / EN 1092-2					ASME/ANSI			BS 10		JIS B2220		
	PN 6	PN 10	PN 16	PN 25	PN 40	class 125	class 150	class 300	tab D	tab E	5K	10K	16K
40	☐	✓	✓	✓	✓	✓	✓	●	☐	☐	●	●	●
50	☐	✓	✓	✓	✓	✓	✓	✗	●	●	●	●	✗
65	☐	✓	✓	✓	✓	✓	✓	●	●	●	●	●	✓
80	☐	✓	✓	✓	✓	✓	✓	●	●	●	●	●	●
100	☐	✓	✓	●	●	✓	✓	✗	●	✓	✗	●	●
125	☐	✓	✓	●(1)	●(1)	✓	✓	✗	✓	✓(PN6)	✓	●	●(1)
150	☐	✓	✓	●(1)	●(1)	✓	✓	✗	●	●	●	✓	✗
200	☐	✓	✓	●	✗	✓	✓	✗	●	●	●	●	✗
250	☐	✓	✓	✗	✗	✓	✓	✗	✗	●	●	●	✗
300	☐	✓	✓	✗	✗	✓	✓	✗	●	●	●	✓(1)	✗
350	☐	✓	✓	✗	✗	✓	✓	✗	●	●	●	●	✗
400	☐	✓	✓	✗	✗	✓	✓	✗	●	●	●	●	●
450	☐	✓	✓	✗	✗	✓	✓	✗	✗	●	●	✓	✗
500	☐	✓	✓	✗	✗	✓	✓	✗	✗	✗	●	✓	✗
600	☐	✓	✓	●	✗	✓	✓	✗	✗	✗	●	✗	✗
700	☐	✓	✓	✗	✗		✓	✗			●	✓	✗
800	☐	✓	✓	✗	✗		✓	✗			●	✓	✗

✓ standard on request    ☐ only body PN 6 version not possible    ● on request    ✗ not possible  
 (1) only with ductile iron bodies  
 (2) standard with ductile iron and steel bodies, on request with different materials



### Bolts and rods dimensions

DN	Wafer valves											
	PN 6			PN 10			PN 16			ANSI 150		
	Bolts	Rods	N°	Bolts	Rods	N°	Bolts	Rods	N°	Bolts	Rods	N°
40	M12x80	M12x90	4	M16x90	M16x100	4	M16x90	M16x100	4	M14x90	M14x110	4
50	M12x90	M12x100	4	M16x100	M16x120	4	M16x100	M16x120	4	M16x100	M16x130	4
65	M12x100	M12x110	4	M16x110	M16x130	8	M16x110	M16x130	8	M16x110	M16x140	4
80	M16x100	M16x120	4	M16x110	M16x130	8	M16x110	M16x130	8	M16x120	M16x150	4
100	M16x110	M16x120	4	M16x120	M16x140	8	M16x120	M16x140	8	M16x120	M16x150	8
125	M16x120	M16x140	8	M16x120	M16x150	8	M16x120	M16x150	8	M20x130	M20x160	8
150	M16x120	M16x140	8	M20x130	M20x160	8	M20x130	M20x160	8	M20x140	M20x160	8
200	M16x130	M16x150	8	M20x140	M20x170	8	M20x140	M20x170	12	M20x150	M20x170	8
250	M16x140	M16x160	12	M20x150	M20x180	12	M24x150	M24x180	12	M22x160	M22x190	12
300	M20x150	M20x180	12	M20x160	M20x190	12	M24x160	M24x190	12	M22x170	M22x210	12
350	M20x150	M20x180	12	M20x160	M20x190	16	M24x170	M24x200	16	M24x180	M24x220	12
400	M20x180	M20x210	16	M24x190	M24x220	16	M27x210	M27x240	16	M27x210	M27x250	16
450	M20x190	M20x220	16	M24x200	M24x230	20	M27x220	M27x250	20	M27x230	M27x270	16
500	M20x210	M20x240	20	M24x210	M24x240	20	M30x240	M30x280	20	M27x250	M27x290	20
600	M24x240	M24x270	20	M27x250	M27x290	20	M33x270	M33x320	20	M33x290	M33x340	20
700	M24x250	M24x280	24	M27x260	M27x310	24	M33x280	M33x330	24	M33x350	M33x400	28
800	M27x280	M27x320	24	M30x290	M30x350	24	M36x320	M36x360	24	M39x400	M33x460	28

DN	Lug valves							
	PN 6		PN 10		PN 16		ANSI 150	
	Bolts	N°	Bolts	N°	Bolts	N°	Bolts	N°
40	M12x30	8	M16x30	8	M16x30	8	M14x30	8
50	M12x35	8	M16x35	8	M16x35	8	M16x35	8
65	M12x35	8	M16x40	16	M16x40	16	M16x40	8
80	M16x40	8	M16x40	16	M16x40	16	M16x40	8
100	M16x40	8	M16x40	16	M16x40	16	M16x45	16
125	M16x45	16	M16x45	16	M16x45	16	M20x50	16
150	M16x45	16	M20x45	16	M20x45	16	M20x50	16
200	M16x50	16	M20x50	16	M20x50	24	M20x55	16
250	M16x55	24	M20x55	24	M24x55	24	M22x60	24
300	M20x60	24	M20x60	24	M24x60	24	M22x60	24
350	M20x60	24	M20x60	32	M24x65	32	M24x65	24
400	M20x70	32	M24x70	32	M27x70	32	M27x80	32
450	M20x80	32	M24x80	40	M27x80	40	M27x80	32
500	M20x80	40	M24x80	40	M30x80	40	M27x90	40
600	M24x90	40	M27x90	40	M33x100	40	M33x100	40
700	M24x100	48	M27x100	48	M33x110	48	M33x130	56
800	M27x110	48	M30x120	48	M36x130	48	M39x150	56

**NOTE 1** Screw and rod dimensions have been calculated with WELDING NECK flanges PN 6/10/16 (EN1092-1 Type 11) ANSI150 (ANSI B16.5)

**NOTE 2** Number of nuts should be double when WAFER valves are assembled with threaded rods.

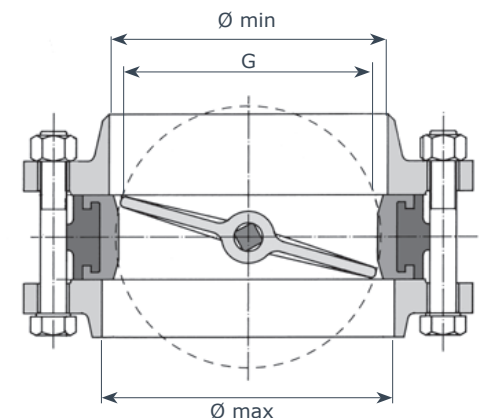

DN	40	50	65	80	100	125	150	200	250	300	350	400	450	500	600	700	800
G	36	35	50	67	87	113	140	191	241	289	332	376	430	475	575	670	757
Ø min	46	44	60	75	98	122	148	196	244	296	342	378	440	485	585	681	782
Ø max	49	62	80	93	118	146	175	225	275	330	372	422	450	500	600	717	815



### Installation

#### Assembly



1 - Leave a space between flanges so that valve can be easily inserted and removed.

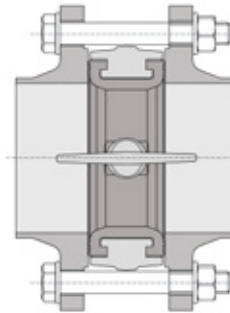

2 - Open completely the valve before tightening flanges.

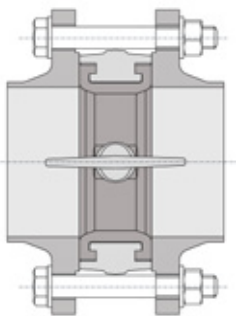

3 - Tighten bolts till flanges are in contact with valve body.

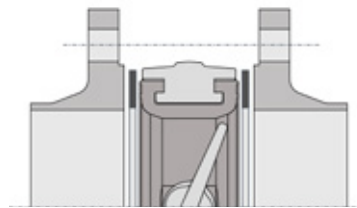

**4 - NOTE:**  
do not insert other packing between flange and valve.

**NOTE:** Weld the pipe only in spots with the valve between flanges. Remove the valve before finishing welding to avoid that heat damage the seat. Clean carefully the welding to avoid that slags damage the seat.

#### Installation for powders and muddy fluids

In case of use with powders or muddy fluids, install the valve with horizontal rotation axis, to allow sediments to flow easily on opening.

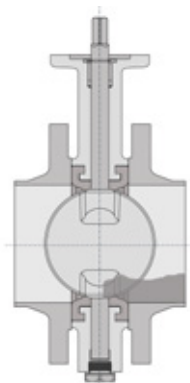

**Wrong**  
Vertical rotation axis

←  
powders or muddy fluids

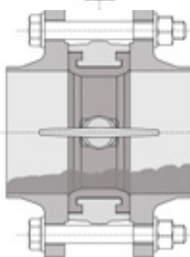

**Right**  
Horizontal rotation axis

←  
powders or muddy fluids

**This type of installation is always advisable with valve diameters over DN 400.**

#### End piping installation

When valves are installed end of piping, a counterflange as per dwg type B is needed to secure tightness at max pressure.

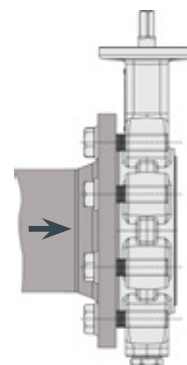

Type A installation without counterflange

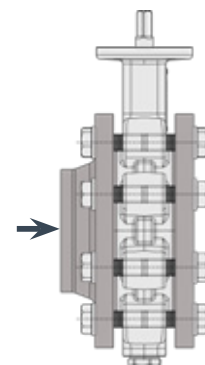

Type B installation with counterflange

valve type	P <sub>max</sub> (Bar)	
	type A inst.	type B inst.
BLPD	4	6
BLKI	6	16
BLKA	16	20
BLKX	16	25



### Handlevers

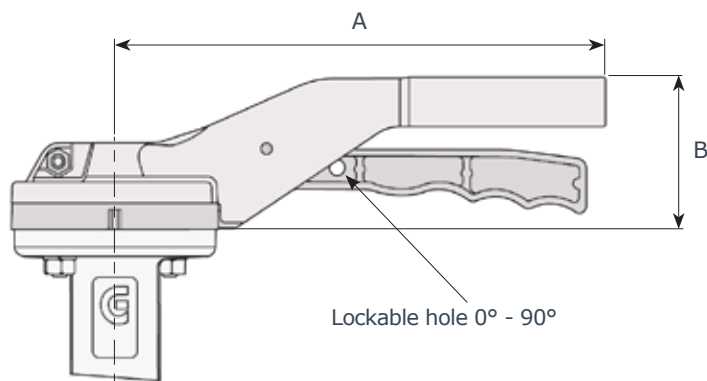

DN	A	B	D	Kg	
				aluminium	st. steel
40 - 100	220	67	93	0.60	1.80
125 - 150	275	67	93	0.65	2.05
200 - 300	340	76	125	1	--

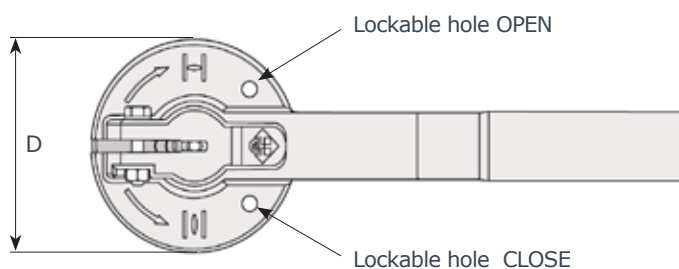

**Note:** DN 250 - 300 handlever not recommended (PD series excluded)

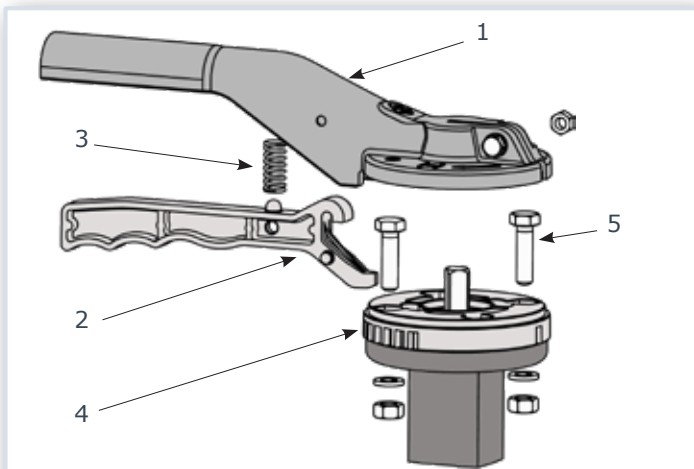

### OPTIONALS

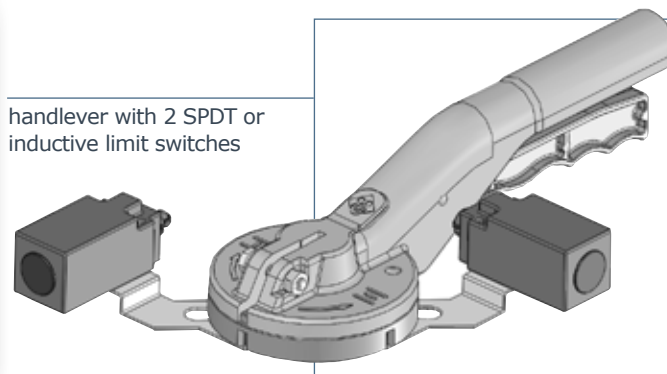
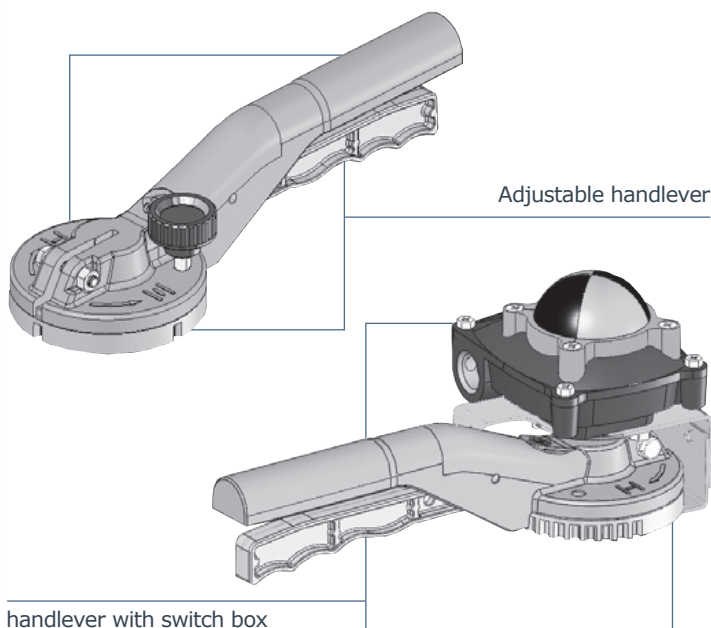

	DN40 - 300	DN40 - 150
1	lever	aluminium
2	trigger	aluminium
3	spring	stainless steel
4	disc positioning	aluminium
5	screws	stainless steel

positioning disc DN 40 - 150 designed for flanges ISO 5211 F05/F07

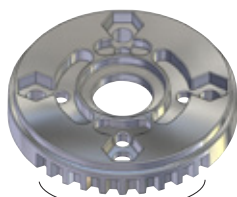

10 positions

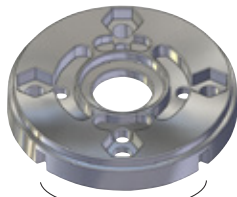

Open - Closed

positioning disc with two types of regulation: 10 positions or Open/Close



### Gearboxes Aluminium body - HW Series

#### Coupling valve - actuators

DN	"	PD	KI			KA	KX
			p = 6 bar	p = 10 bar	p = 16 bar		
40	1 <sup>1/2</sup>	--	HW070	HW070	HW070	--	--
50	2	--	HW070	HW070	HW070	HW070	HW070
65	2 <sup>1/2</sup>	--	HW070	HW070	HW070	HW070	HW070
80	3	HW070	HW070	HW070	HW070	HW070	HW070
100	4	HW070	HW070	HW070	HW070	HW070	HW070
125	5	HW070	HW070	HW070	HW070	HW070	HW070
150	6	HW070	HW070	HW070	HW070	HW070	HW070
200	8	HW102	HW102	HW102	HW102	HW102	HW102
250	10	HW102	HW102	HW102	HW102	HW102	HW102
300	12	HW102	HW102	HW102	HW102	HW102	--
350	14	HW140	HW140	HW140	HW140	HW140	--
400	16	HW140	HW140	HW140	HW140	HW165	--
450	18	HW165	HW165	HW165	HW165	HW165	--
500	20	HW165	HW165	HW165	HW165	HW254	--
600	24	HW254	HW254	HW254	--	--	--
700	28	--	HW254	HW254	--	--	--
800	32	--	HW254	HW254	--	--	--

HW series	
body:	aluminium
worm gears:	steel
sector gear:	ductile iron
shaft:	stainless steel
handwheel:	steel
protection:	IP65
T:	-20 / +120 °C

DN	"	A
40	1 <sup>1/2</sup>	130
50	2	138
65	2 <sup>1/2</sup>	144
80	3	158
100	4	173
125	5	186
150	6	202
200	8	240
250	10	270
300	12	300
350	14	330
400	16	355
450	18	400
500	20	422
600	24	495
700	28	550
800	32	640

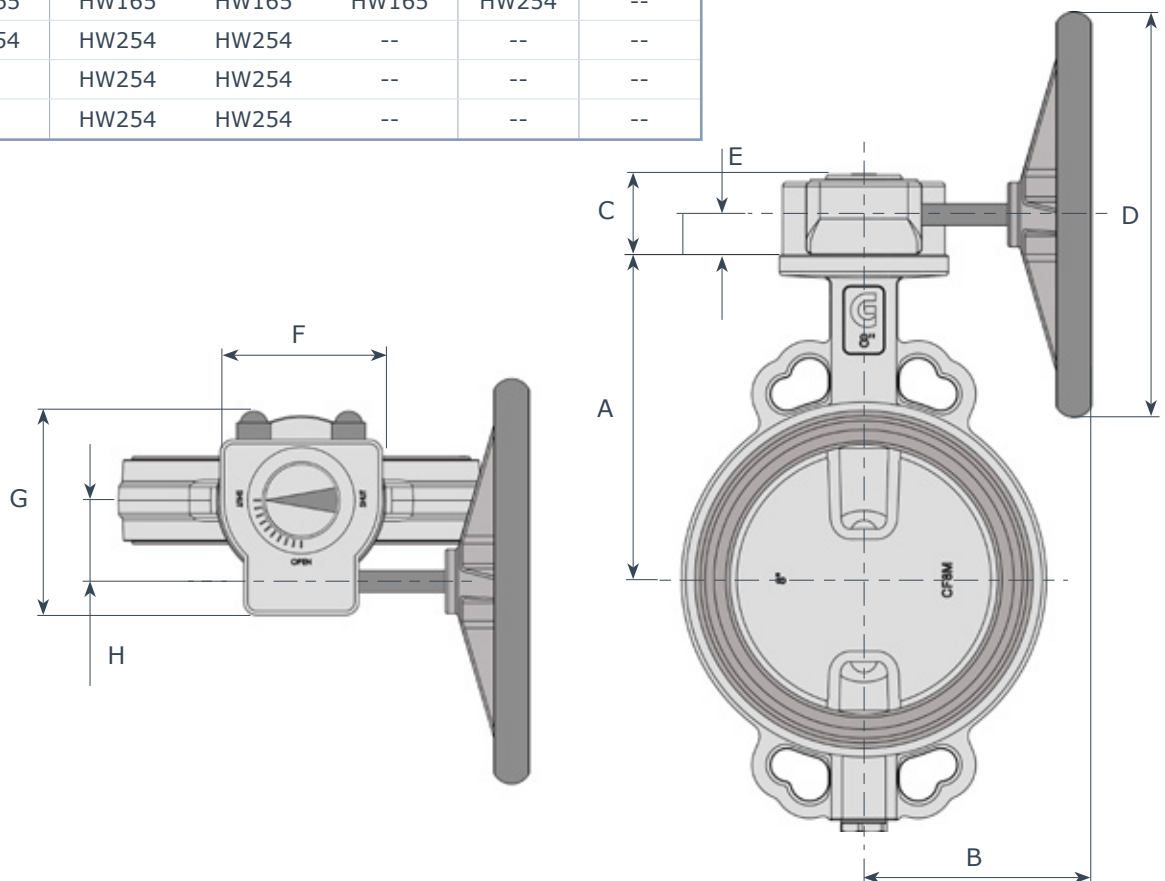

Mod.	B	C	D	E	F	G	H	Kg
HW070	165	48	140	27	80	115	42	1.6
HW102	240	56	300	33	120	150	60	3
HW140	250	95	400*	51	185	225	80	10
HW165	395	105	600	61	230	268	105	20
HW254	416	125	700	80	265	332	130	25

\* for DN 350: D = 350



### Gearboxes Cast Iron body - AB Series

#### Coupling valve - actuators

DN	"	PD	KI			KA	KX
			p = 6 bar	p = 10 bar	p = 16 bar		
40	1½	--	AB150	AB150	AB150	AB150	AB150
50	2	--	AB150	AB150	AB150	AB150	AB150
65	2½	--	AB150	AB150	AB150	AB150	AB150
80	3	AB150	AB150	AB150	AB150	AB150	AB150
100	4	AB150	AB150	AB150	AB150	AB150	AB150
125	5	AB150	AB150	AB150	AB150	AB150	AB150
150	6	AB150	AB150	AB150	AB150	AB150	AB150
200	8	AB215	AB215	AB215	AB215	AB215	AB215
250	10	AB550	AB550	AB550	AB550	AB550	AB550
300	12	AB550	AB550	AB550	AB550	AB550	--
350	14	AB880	AB880	AB880	AB880	AB880	--
400	16	AB880	AB880	AB880	AB880	AB880	--
450	18	AB880	AB880	AB880	AB880	AB1250	--
500	20	AB880	AB880	AB880	AB880	AB1250	--
600	24	AB1250	AB1250	AB1250	--	AB1954	--
700	28	--	AB1950	AB1950	--	AB6804	--
800	32	--	AB1950	AB1954	--	AB6806	--

#### AB series

body:	ductile iron
worm gears:	steel
sector gear:	ductile iron
shaft:	steel
handwheel:	steel
protection:	IP67
T:	-20 / +120 °C

low/high temperature execution on request

#### Waterproof valve shaft extension

When necessary, it's possible to extend the valve shaft as indicated in the figure. Construction is in carbon steel with protective paint (on request stainless steel).

"L" measure should be indicated when ordering.

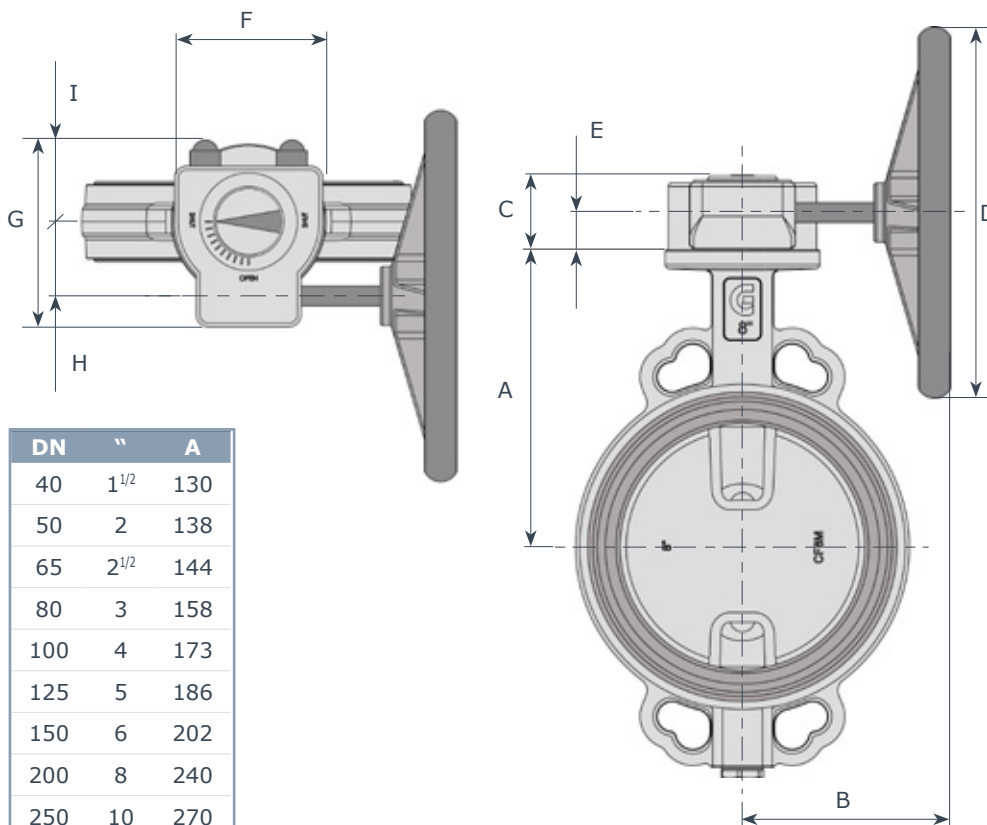

DN	"	A
40	1½	130
50	2	138
65	2½	144
80	3	158
100	4	173
125	5	186
150	6	202
200	8	240
250	10	270
300	12	300
350	14	330
400	16	355
450	18	400
500	20	422
600	24	495
700	28	550
800	32	640

Mod.	B	C	D	E	F	G	H	I	Kg
AB150	157.5	55	200	27	80	124	43	58	2.2
AB215	217	63	200	29	102	128	52	48	3.5
AB550	282	88	300	41	138	174	71	69	8.5
AB880	282	93	400	42	200	226	86	100	14
AB1250	322	102	500	48	220	258	105	110	22
AB1950	425	126	600	55	285	323	130	143	32
AB1954	398	126	600	55	285	323	130	143	39
AB6804	451	159	600	59	370	407	182	170	62.5
AB6806	451	159	600	59	370	407	182	170	64.2

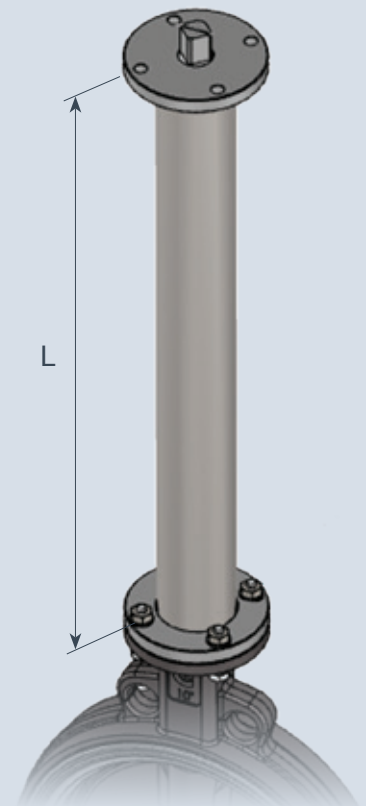

Our technical department is available to solve special applications.



### Pneumatic actuator DA / DOUBLE ACTING

#### Rack & Pinion Actuators - MT

Max air pressure: 10 bar Double travel stop  
 Temperature: -20°C / +80°C open/close: ±10°  
 Torque range: 31/3564 Nm

#### Scotch Yoke Actuators - CHD Series

Max air pressure: 6 bar Nmt  
 Temperature: -20 / +80°C Double travel stop  
 Torque Range: 1200/305000 open/close: ±6°

valve seat: EPDM/NBR			fluid: H <sub>2</sub> O				T: 20°C				operating air pressure: ≥5.5 bar					
DN	"	M	PD				KI				KA		KX			
			P=6 B	G	P=10 B	G	P=6 B	G	P=10 B	G	P=16 B	G	mod.	G	mod.	G
40	1½	130	≈	≈	≈	≈	MT 15	16	MT 15	16	MT 15	16	MT 15	16	≈	≈
50	2	138	≈	≈	≈	≈	MT 15	16	MT 15	16	MT 15	16	MT 15	16	MT 15	16
65	2½	144	≈	≈	≈	≈	MT 15	16	MT 15	16	MT 15	16	MT 15	16	MT 20	16
80	3	158	MT 15	16	MT 15	16	MT 17	16	MT 20	16	MT 20	16	MT 20	16	MT 25	16
100	4	173	MT 15	16	MT 15	16	MT 20	16	MT 25	16	MT 25	16	MT 25	16	MT 25	16
125	5	186	MT 17	16	MT 20	16	MT 25	16	MT 25	16	MT 30	16	MT 30	16	MT 30	16
150	6	202	MT 20	16	MT 20	16	MT 25	16	MT 30	16	MT 30	16	MT 30	16	MT 35	16
200	8	240	MT 25	14	MT 30	14	MT 35	14	MT 40	14	MT 45	14	MT 45	14	MT 50	14
250	10	270	MT 35	14	MT 35	14	MT 40	14	MT 45	14	MT 50	14	MT 50	14	MT 55	14
300	12	300	MT 40	14	MT 45	14	MT 45	14	MT 50	14	MT 55	14	MT 55	14	≈	≈
350	14	330	MT 50	100	MT 50	100	MT 55	100	MT 60	100	MT 65	100	MT 65	100	≈	≈
400	16	355	MT 55	100	MT 60	100	MT 55	100	MT 60	100	MT 65	100	MT 70	100	≈	≈
450	18	400	MT 55	100	MT 60	100	MT 55	100	MT 60	100	MT 65	100	MT 70	100	≈	≈
500	20	422	MT 55	100	MT 60	100	MT 60	100	MT 60	100	MT 70	100	CHD16-025	0	≈	≈
600	24	495	MT 70	100	MT 70	100	MT 70	100	MT 75	100	≈	≈	CHD16-035	0	≈	≈
700	28	550	≈	≈	≈	≈	MT 75	150	CHD16-030	200	≈	≈	CHD25-038	0	≈	≈
800	32	640	≈	≈	≈	≈	CHD16-030	200	CHD16-030	200	≈	≈	CHD30-043	200	≈	≈

valve seat: EPDM/NBR			fluid: Aria				T: 20°C				operating air pressure: ≥5,5 bar			
valve seat: FKM (n.a. for PD 10bar)			fluid: H <sub>2</sub> O											

DN	"	M	PD				KI					
			P=6 B	G	P=10 B	G	P=6 B	G	P=10 B	G	P=16 B	G
40	1½	130	≈	≈	≈	≈	MT 15	16	MT 15	16	MT 15	16
50	2	138	≈	≈	≈	≈	MT 15	16	MT 15	16	MT 17	16
65	2½	144	≈	≈	≈	≈	MT 17	16	MT 17	16	MT 17	16
80	3	158	MT 15	16	MT 15	16	MT 20	16	MT 25	16	MT 25	16
100	4	173	MT 15	16	MT 17	16	MT 25	16	MT 30	16	MT 30	16
125	5	186	MT 20	16	MT 25	16	MT 30	16	MT 35	16	MT 35	16
150	6	202	MT 25	16	MT 25	16	MT 30	16	MT 35	16	MT 40	16
200	8	240	MT 30	14	MT 35	14	MT 35	14	MT 50	14	MT 50	14
250	10	270	MT 35	14	MT 40	14	MT 45	14	MT 50	14	MT 60	50
300	12	300	MT 45	14	MT 50	14	MT 50	14	MT 60	50	MT 60	50
350	14	330	MT 55	100	MT 55	100	MT 60	100	MT 65	100	MT 70	100
400	16	355	MT 60	100	MT 60	100	MT 60	100	MT 70	100	MT 70	100
450	18	400	MT 60	100	MT 60	100	MT 65	100	MT 70	100	MT 70	100
500	20	422	MT 60	100	MT 60	100	MT 65	100	MT 75	100	MT 75	100
600	24	495	MT 70	100	MT 75	100	CHD16-025	0	CHD16-025	0	≈	≈
700	28	550	≈	≈	≈	≈	CHD16-030	200	CHD16-030	200	≈	≈
800	32	640	≈	≈	≈	≈	CHD16-030	200	CHD16-035	200	≈	≈

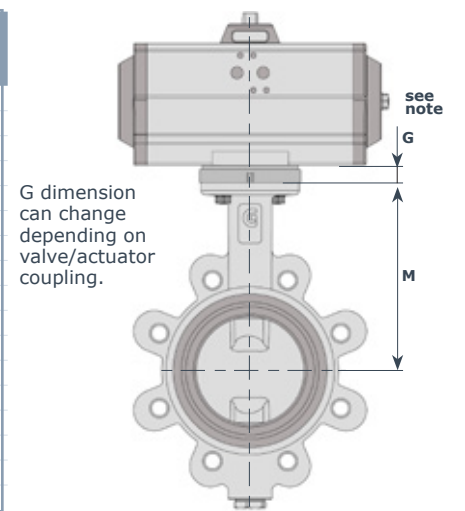

valve seat: EPDM/NBR			fluid: H <sub>2</sub> O				T: 20°C				operating air pressure: 4-5 bar			
----------------------	--	--	-------------------------	--	--	--	---------	--	--	--	---------------------------------	--	--	--

DN	"	M	PD				KI				KA		KX			
			P=6 B	G	P=10 B	G	P=6 B	G	P=10 B	G	P=16 B	G	mod.	G	mod.	G
40	1½	130	≈	≈	≈	≈	MT 15	16	MT 15	16	MT 15	16	MT 15	16	≈	≈
50	2	138	≈	≈	≈	≈	MT 15	16	MT 15	16	MT 15	16	MT 15	16	MT 17	16
65	2½	144	≈	≈	≈	≈	MT 15	16	MT 15	16	MT 17	16	MT 17	16	MT 20	16
80	3	158	MT 15	16	MT 15	16	MT 20	16	MT 25	16	MT 25	16	MT 25	16	MT 30	16
100	4	173	MT 15	16	MT 20	16	MT 25	16	MT 25	16	MT 30	16	MT 30	16	MT 35	16
125	5	186	MT 25	16	MT 25	16	MT 30	16	MT 30	16	MT 35	16	MT 35	16	MT 35	16
150	6	202	MT 25	16	MT 25	16	MT 30	16	MT 35	16	MT 35	16	MT 35	16	MT 40	14
200	8	240	MT 30	14	MT 35	14	MT 35	14	MT 45	14	MT 50	14	MT 50	14	MT 55	14
250	10	270	MT 35	14	MT 40	14	MT 45	14	MT 50	14	MT 55	14	MT 55	14	MT 60	50
300	12	300	MT 45	14	MT 50	14	MT 55	14	MT 55	14	MT 60	50	MT 60	50	≈	≈
350	14	330	MT 50	100	MT 55	100	MT 60	100	MT 65	100	MT 70	100	MT 70	100	≈	≈
400	16	355	MT 60	100	MT 60	100	MT 65	100	MT 65	100	MT 70	100	MT 75	100	≈	≈
450	18	400	MT 60	100	MT 60	100	MT 65	100	MT 65	100	MT 70	100	CHD16-025	200	≈	≈
500	20	422	MT 60	100	MT 60	100	MT 65	100	MT 70	100	MT 75	100	CHD16-030	0	≈	≈
600	24	495	MT 75	100	MT 75	100	CHD16-025	0	CHD16-030	0	≈	≈	CHD25-035	200	≈	≈
700	28	495	≈	≈	≈	≈	CHD16-030	200	CHD16-035	200	≈	≈	CHD25-043	0	≈	≈
800	32	640	≈	≈	≈	≈	CHD16-035	200	CHD16-035	200	≈	≈	CHD30-048	200	≈	≈



valve seat: EPDM/NBR      fluid: Aria      T: 20°C      operating air pressure: 4-5 bar  
 valve seat: FKM (n.a. for PD 10bar)      fluid: H<sub>2</sub>O

DN	"	M	PD				KI							
			P=6 B	G	P=10 B	G	P=6 B	G	P=10 B	G	P=16 B	G		
			EPDM/NBR seat only											
40	1½	130	~	~	~	~	MT 15	16	MT 15	16	MT 15	16	MT 15	16
50	2	138	~	~	~	~	MT 15	16	MT 15	16	MT 15	16	MT 17	16
65	2½	144	~	~	~	~	MT 17	16	MT 17	16	MT 17	16	MT 17	16
80	3	158	MT 15	16	MT 15	16	MT 25	16	MT 25	16	MT 30	16	MT 30	16
100	4	173	MT 15	16	MT 20	16	MT 30	16	MT 30	16	MT 30	16	MT 30	16
125	5	186	MT 25	16	MT 30	16	MT 30	16	MT 30	16	MT 35	16	MT 35	16
150	6	202	MT 35	16	MT 35	16	MT 35	16	MT 35	16	MT 40	16	MT 40	16
200	8	240	MT 35	14	MT 40	14	MT 40	14	MT 50	14	MT 50	14	MT 50	14
250	10	270	MT 45	14	MT 45	14	MT 50	14	MT 50	14	MT 55	14	MT 55	14
300	12	300	MT 50	14	MT 55	14	MT 55	14	MT 60	50	MT 60	50	MT 60	50
350	14	330	MT 60	100	MT 60	100	MT 60	100	MT 65	100	MT 70	100	MT 70	100
400	16	355	MT 60	100	MT 60	100	MT 60	100	MT 70	100	MT 70	100	MT 70	100
450	18	400	MT 65	100	MT 65	100	MT 65	100	MT 70	100	MT 70	100	MT 70	100
500	20	422	MT 65	100	MT 65	100	MT 65	100	MT 70	100	MT 75	100	MT 75	100
600	24	495	CHD16-025	0	CHD16-025	0	CHD16-030	0	CHD16-030	0	~	~	~	~
700	28	550	~	~	~	~	CHD16-035	200	CHD16-035	200	~	~	~	~
800	32	640	~	~	~	~	CHD16-035	200	CHD25-035	0	~	~	~	~

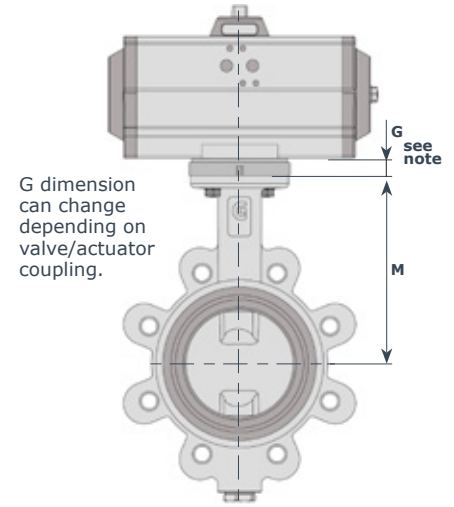

### Pneumatic actuator SR / SPRING RETURN

#### Rack & Pinion Actuators - MTS

Max air pressure: 10 bar      Double travel stop  
 Temperature: -20°C / +80°C      open/close: ±10°  
 Torque range: 31/3564 Nm

#### Scotch Yoke Actuators - CHD Series

Max air pressure: 6 bar      Nmt  
 Temperature: -20 / +80°C      Double travel stop  
 Torque Range: 1200/305000      open/close: ±6°

valve seat: EPDM/NBR      fluid: H<sub>2</sub>O      T: 20°C      operating air pressure: ≥5.5 bar

DN	"	PD				KI						KA		KX	
		P=6 B	G	P=10 B	G	P=6 B	G	P=10 B	G	P=16 B	G	mod.	G	mod.	G
40	1½	~	~	~	~	MTS 15	16	MTS 15	16	MTS 15	16	MTS 20	16	~	~
50	2	~	~	~	~	MTS 15	16	MTS 15	16	MTS 15	16	MTS 20	16	MTS 20	16
65	2½	~	~	~	~	MTS 17	16	MTS 17	16	MTS 20	16	MTS 25	16	MTS 30	16
80	3	MTS 15	16	MTS 15	16	MTS 25	16	MTS 30	16	MTS 30	16	MTS 30	16	MTS 35	16
100	4	MTS 17	16	MTS 25	16	MTS 30	16	MTS 35	16	MTS 35	16	MTS 35	16	MTS 40	16
125	5	MTS 30	16	MTS 30	16	MTS 35	16	MTS 35	16	MTS 40	16	MTS 40	16	MTS 40	16
150	6	MTS 30	16	MTS 35	16	MTS 35	16	MTS 45	16	MTS 45	16	MTS 45	16	MTS 45	16
200	8	MTS 35	14	MTS 45	14	MTS 45	14	MTS 50	14	MTS 55	14	MTS 55	14	MTS 60	50
250	10	MTS 45	14	MTS 45	14	MTS 50	14	MTS 55	14	MTS 60	50	MTS 60	50	MTS 65	50
300	12	MTS 50	14	MTS 60	50	MTS 60	50	MTS 60	50	MTS 60	50	MTS 65	50	~	~
350	14	MTS 60	100	MTS 65	100	MTS 65	100	MTS 70	100	MTS 75	100	MTS 75	100	~	~
400	16	MTS 65	100	MTS 70	100	MTS 65	100	MTS 70	100	MTS 75	100	CHD16-030B01	200	~	~
450	18	MTS 65	100	MTS 70	100	MTS 70	100	MTS 70	100	MTS 75	100	CHD25-035B01	200	~	~
500	20	MTS 65	100	MTS 70	100	MTS 70	100	MTS 75	100	CHD16-030B01	0	CHD25-038B01	200	~	~
600	24	CHD16-030B01	0	CHD16-035B01	0	CHD16-035B01	0	CHD25-035B01	200	~	~	CHD30-048B01	200	~	~
700	28	~	~	~	~	CHD25-038B01	0	CHD25-043B01	0	~	~	CHD35-053B01	200	~	~
800	32	~	~	~	~	CHD25-043B01	0	CHD25-043B01	0	~	~	CHD35-058B01	200	~	~

valve seat: EPDM/NBR      fluid: Aria      T: 20°C      operating air pressure: ≥5,5 bar  
 valve seat: FKM      fluid: H<sub>2</sub>O

DN	"	PD				KI							
		P=6 B	G	P=10 B	G	P=6 B	G	P=10 B	G	P=16 B	G		
			EPDM/NBR seat only										
40	1½	~	~	~	~	MTS 20	16	MTS 20	16	MTS 20	16	MTS 20	16
50	2	~	~	~	~	MTS 20	16	MTS 20	16	MTS 20	16	MTS 20	16
65	2½	~	~	~	~	MTS 20	16	MTS 20	16	MTS 20	16	MTS 25	16
80	3	MTS 15	16	UTS 17	16	MTS 30	16	MTS 35	16	MTS 35	16	MTS 35	16
100	4	MTS 20	16	UTS 30	16	MTS 35	16	MTS 35	16	MTS 35	16	MTS 40	16
125	5	MTS 30	16	UTS 35	16	MTS 35	16	MTS 35	16	MTS 40	16	MTS 45	16
150	6	MTS 35	16	UTS 40	16	MTS 40	16	MTS 45	16	MTS 45	16	MTS 45	16
200	8	MTS 40	14	UTS 45	14	MTS 50	14	MTS 55	14	MTS 60	50	MTS 60	50
250	10	MTS 50	14	UTS 50	14	MTS 55	14	MTS 60	50	MTS 65	50	MTS 65	50
300	12	MTS 60	50	UTS 60	50	MTS 60	50	MTS 65	50	MTS 70	100	MTS 70	100
350	14	MTS 70	100	UTS 70	100	MTS 70	100	MTS 70	100	MTS 75	100	MTS 75	100
400	16	MTS 70	100	UTS 70	100	MTS 70	100	MTS 70	100	CHD16-030A01	200	CHD16-030A01	200
450	18	MTS 70	100	UTS 70	100	MTS 70	100	MTS 70	100	CHD16-030B01	200	CHD16-030B01	200
500	20	MTS 70	100	UTS 70	100	MTS 70	100	MTS 75	100	CHD16-035B01	0	CHD16-035B01	0
600	24	CHD25-035B01	200	CHD25-035B01	200	CHD25-035B01	200	CHD25-038B01	200	~	~	~	~
700	28	~	~	~	~	CHD25-043B01	0	CHD30-043B01	200	~	~	~	~
800	32	~	~	~	~	CHD30-043B01	200	CHD30-043B01	200	~	~	~	~



valve seat: EPDM/NBR      fluid: H<sub>2</sub>O      T: 20°C      operating air pressure: 4-5 bar

DN	"	PD				KI				KA		KX			
		P=6 B	G	P=10 B	G	P=6 B	G	P=10 B	G	P=16 B	G	mod.	G	mod.	G
40	1½	≈	≈	≈	≈	MTS4 17	16	MTS4 20	16	MTS4 20	16	MTS4 20	16	≈	≈
50	2	≈	≈	≈	≈	MTS4 20	16	MTS4 20	16	MTS4 20	16	MTS4 25	16	MTS4 25	16
65	2½	≈	≈	≈	≈	MTS4 25	16	MTS4 25	16	MTS4 25	16	MTS4 25	16	MTS4 30	16
80	3	MTS4 17	16	MTS4 17	16	MTS4 30	16	MTS4 35	16	MTS4 35	16	MTS4 35	16	MTS4 35	16
100	4	MTS4 20	16	MTS4 30	16	MTS4 35	16	MTS4 35	16	MTS4 40	16	MTS4 35	16	MTS4 40	16
125	5	MTS4 30	16	MTS4 35	16	MTS4 40	16	MTS4 40	16	MTS4 45	16	MTS4 45	16	MTS4 45	16
150	6	MTS4 40	16	MTS4 40	16	MTS4 40	16	MTS4 45	16	MTS4 45	16	MTS4 45	16	MTS4 50	16
200	8	MTS4 40	14	MTS4 45	14	MTS4 50	14	MTS4 55	14	MTS4 60	50	MTS4 60	50	MTS4 65	50
250	10	MTS4 45	14	MTS4 50	14	MTS4 55	14	MTS4 60	50	MTS4 65	50	MTS4 65	50	MTS4 70	100
300	12	MTS4 55	14	MTS 65	50	MTS4 60	50	MTS4 65	50	MTS 70	100	MTS 70	100	≈	≈
350	14	MTS4 65	100	MTS 70	100	MTS 70	100	MTS 70	100	CHD16-025A01	200	CHD16-030A01	200	≈	≈
400	16	MTS 70	100	MTS 70	100	MTS 70	100	MTS 70	100	CHD16-030A01	200	CHD25-035A01	200	≈	≈
450	18	MTS 70	100	MTS 70	100	MTS 70	100	MTS 75	100	CHD16-030A01	200	CHD25-038A01	200	≈	≈
500	20	MTS 70	100	MTS 70	100	MTS 70	100	MTS 75	100	CHD25-035A01	200	CHD25-043A01	200	≈	≈
600	24	CHD25-035A01	200	CHD25-038A01	200	CHD25-038A01	200	CHD25-043A01	200	≈	≈	CHD30-053A01	200	≈	≈
700	28	≈	≈	≈	≈	CHD30-043A01	200	CHD30-043A01	200	≈	≈	CHD35-058A01	200	≈	≈
800	32	≈	≈	≈	≈	CHD30-043A01	200	CHD30-048A01	200	≈	≈	CHD40-063A01	200	≈	≈

valve seat: EPDM/NBR      fluid: Aria      T: 20°C      operating air pressure: 4-5 bar  
valve seat: FKM      fluid: H<sub>2</sub>O

DN	"	PD				KI					
		P=6 B	G	P=10 B	G	P=6 B	G	P=10 B	G	P=16 B	G
40	1½	≈	≈	≈	≈	MTS4 20	16	MTS4 25	16	MTS4 25	16
50	2	≈	≈	≈	≈	MTS4 20	16	MTS4 25	16	MTS4 25	16
65	2½	≈	≈	≈	≈	MTS4 25	16	MTS4 25	16	MTS4 25	16
80	3	MTS4 17	16	MTS4 20	16	MTS4 30	16	MTS4 35	16	MTS4 40	16
100	4	MTS4 25	16	MTS4 30	16	MTS4 40	16	MTS4 40	16	MTS4 40	16
125	5	MTS4 35	16	MTS4 40	16	MTS4 40	16	MTS4 45	16	MTS4 45	16
150	6	MTS4 45	16	MTS4 45	16	MTS4 45	16	MTS4 50	16	MTS4 50	16
200	8	MTS4 45	14	MTS4 50	14	MTS4 50	14	MTS4 60	50	MTS4 60	50
250	10	MTS4 55	14	MTS4 55	14	MTS4 60	50	MTS4 60	50	MTS 70	100
300	12	MTS4 60	50	MTS4 65	50	MTS4 65	50	MTS4 65	50	MTS 70	100
350	14	MTS 70	100	MTS 70	100	MTS 70	100	MTS 70	100	CHD16-030A01	200
400	16	MTS 70	100	MTS 70	100	MTS 70	100	MTS 75	100	CHD16-030A01	200
450	18	MTS 70	100	MTS 70	100	MTS 70	100	CHD16-030A01	200	CHD16-035A01	200
500	20	MTS 70	100	MTS 70	100	MTS 75	100	CHD16-030A01	0	CHD25-038A01	200
600	24	CHD25-038A01	200	CHD25-038A01	200	CHD25-043A01	200	CHD25-043A01	200	≈	≈
700	28	≈	≈	≈	≈	CHD30-043A01	200	CHD30-048A01	200	≈	≈
800	32	≈	≈	≈	≈	CHD30-048A01	200	CHD30-053A01	200	≈	≈

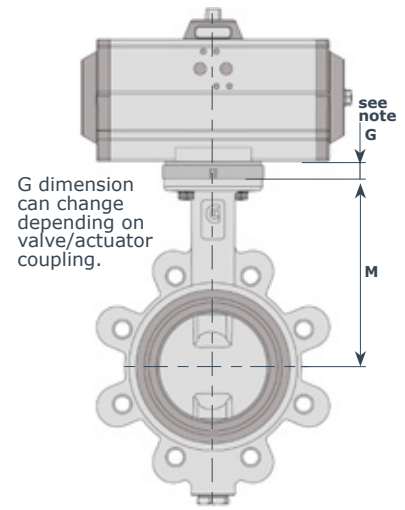

### Declutchable manual gearboxes - emergency lever

<b>GD Series</b>		body:	aluminium	shaft:	stainless steel
		worm gears:	steel	handwheel:	steel
		sector gear:	ductile iron	protection:	IP65
				T:	-20 / +120 °C
∅ valve	DA actuator double action	SR actuator spring return	emergency gearbox type		
DN 40÷150	MT 20÷45	MTS 20÷35	<b>GD070</b>		
DN 40÷300	MT 35÷55	MTS 35÷50	<b>GD102</b>		
DN 200÷400	MT 50÷65	MTS 55÷65	<b>GD140</b>		
DN 450÷600	MT 60	MTS 70÷75	<b>GD165</b>		
DN 600÷800	MT 70÷75	≈	<b>GD254</b>		

<b>ILGD Series</b>		body:	ductile iron GGG40	shaft:	steel
		worm gears:	steel	handwheel:	steel
		sector gear:	ductile iron	protection:	IP65 (on req.)
				T:	-20 / +120 °C
∅ valve	DA actuator double action	SR actuator spring return	emergency gearbox type		
DN 40÷150	MT 15÷45	MTS 15÷35	<b>ILGD 200</b>		
DN 40÷300	MT 35÷55	MTS 35÷55	<b>ILGD 600</b>		
DN 200÷400	MT 50÷65	MTS 50÷65	<b>ILGD 900</b>		
DN 350÷600	MT 60÷70	MTS 60÷70	<b>ILGD 1500</b>		
DN 450÷600	MT 75	MTS 70÷75	<b>ILGD 2400</b>		
DN 600÷800	MT 70÷75	≈	<b>ILGD 5000</b>		

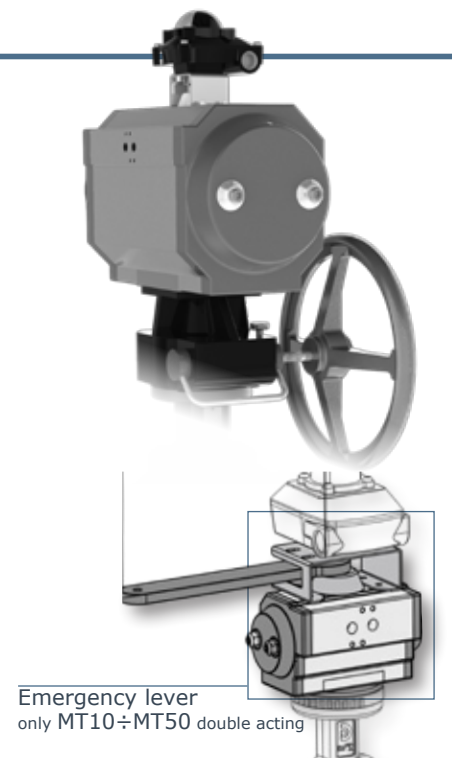



### Hydraulic actuators ARES

- Technical features:
  - » ductile iron cast body
  - » steel rack and pinion
  - » NBR seats
- fluid material:
  - » hydraulic oil type : HPL DIN51524-2 / ISO 6743-4. Viscosity 15/200 cst
- working pressure: 10 - 120 bar
- working temperature: -20°C / +80°C

Compact design, 90° rotation ±5°,  
Travel adjustment in both direction  
of rotation, Flange ISO 5211,  
Double or single acting with spring return

DN	40	50	65	80	100	125	150	200	250
M	130	138	148	158	173	186	202	240	270
DN	300	350	400	450	500	600	700	800	
M	300	330	355	400	422	495	550	640	

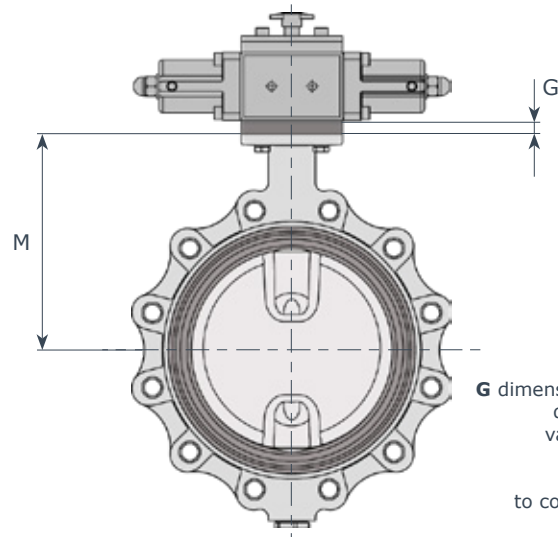

valve seat: <b>NBR / EPDM</b> - Fluid H <sub>2</sub> O - T = 20°C - oil pressure: <b>60 Bar</b>																	
DN	"	DA type - Double Acting								SR type - Spring close							
		PD series	G	KI series	G	KA series	G	KX series	G	PD series	G	KA series	G	KA series	G	KX series	G
40	1 <sup>1/2</sup>	≈	≈	H 28	0	H 28	0	≈	≈	H 40 SRA	0	H 40 SRA	0	H 40 SRA	0	≈	≈
50	2	≈	≈	H 28	0	H 28	0	H 28	0	H 40 SRA	0	H 40 SRA	0	H 40 SRA	0	H 40 SRA	0
65	2 <sup>1/2</sup>	≈	≈	H 28	0	H 28	0	H 28	0	H 40 SRA	0	H 40 SRA	0	H 40 SRA	0	H 40 SRA	0
80	3	H 28	0	H 28	0	H 28	0	H 28	0	H 40 SRA	0	H 40 SRA	0	H 40 SRA	0	H 40 SRA	0
100	4	H 28	0	H 28	0	H 28	0	H 28	0	H 40 SRA	0	H 40 SRA	0	H 40 SRA	0	H 50 SRA	14
125	5	H 28	0	H 28	0	H 28	0	H 28	0	H 40 SRA	0	H 50 SRA	14	H 50 SRA	14	H 50 SRA	14
150	6	H 28	0	H 28	0	H 40	0	H 40	0	H 40 SRA	0	H 50 SRA	14	H 50 SRA	14	H 50 SRA	14
200	8	H 50	0	H 50	0	H 50	0	H 63	50	H 50 SRA	0	H 63 SRA	50	H 63 SRA	50	H 80 SRA	100
250	10	H 50	0	H 50	0	H 50	0	H 63	50	H 50 SRA	0	H 80 SRA	100	H 80 SRA	100	H 80 SRA	100
300	12	H 50	0	H 63	50	H 63	50	≈	≈	H 63 SRA	50	H 80 SRA	100	H 80 SRA	100	≈	≈
350	14	H 63	100	H 80	100	H 80	100	≈	≈	H 80 SRA	100	≈	≈	≈	≈	≈	≈
400	16	H 80	100	H 80	100	≈	≈	≈	≈	H 80 SRA	100	≈	≈	≈	≈	≈	≈
450	18	H 80	100	H 80	100	≈	≈	≈	≈	≈	≈	≈	≈	≈	≈	≈	≈
500	20	H 80	100	≈	≈	≈	≈	≈	≈	≈	≈	≈	≈	≈	≈	≈	≈
600	24	a ric.	a ric.	≈	≈	≈	≈	≈	≈	≈	≈	≈	≈	≈	≈	≈	≈

valve seat: <b>NBR / EPDM</b> - Fluid H <sub>2</sub> O - T = 20°C - oil pressure: <b>120 Bar</b>																	
DN	"	DA type - Double Acting								SR type - Spring close							
		PD series	G	KI series	G	KA series	G	KX series	G	PD series	G	KA series	G	KA series	G	KX series	G
40	1 <sup>1/2</sup>	≈	≈	H 28	0	H 28	0	≈		H 40 SRB	0	H 40 SRB	0	H 40 SRB	0	H 40 SRB	0
50	2	≈	≈	H 28	0	H 28	0	H 28	0	H 40 SRB	0	H 40 SRB	0	H 40 SRB	0	H 40 SRB	0
65	2 <sup>1/2</sup>	≈	≈	H 28	0	H 28	0	H 28	0	H 40 SRB	0	H 40 SRB	0	H 40 SRB	0	H 40 SRB	0
80	3	H 28	0	H 28	0	H 28	0	H 28	0	H 40 SRB	0	H 40 SRB	0	H 40 SRB	0	H 40 SRB	0
100	4	H 28	0	H 28	0	H 28	0	H 28	0	H 40 SRB	0	H 40 SRB	0	H 40 SRB	0	H 40 SRB	0
125	5	H 28	0	H 28	0	H 28	0	H 28	0	H 40 SRB	0	H 40 SRB	0	H 40 SRB	0	H 40 SRB	0
150	6	H 28	0	H 28	0	H 28	0	H 28	0	H 40 SRB	0	H 40 SRB	0	H 40 SRB	0	H 40 SRB	0
200	8	H 50	0	H 50	0	H 50	0	H 50	0	H 50 SRB	0	H 50 SRB	0	H 50 SRB	0	H 63 SRB	50
250	10	H 50	0	H 50	0	H 50	0	H 50	0	H 50 SRB	0	H 63 SRB	50	H 63 SRB	50	H 63 SRB	50
300	12	H 50	0	H 50	0	H 50	0	≈	≈	H 50 SRB	0	H 63 SRB	50	H 63 SRB	50	≈	≈
350	14	H 63	100	H 63	100	H 63	100	≈	≈	H 63 SRB	100	H 80 SRB	100	≈	≈	≈	≈
400	16	H 63	100	H 63	100	H 63	100	≈	≈	H 63 SRB	100	H 80 SRB	100	≈	≈	≈	≈
450	18	H 80	100	H 80	100	H 80	100	≈	≈	H 80 SRB	100	≈	≈	≈	≈	≈	≈
500	20	H 80	100	H 80	100	≈	≈	≈	≈	H 80 SRB	100	≈	≈	≈	≈	≈	≈
600	24	a ric.	a ric.	H 80	100	≈	≈	≈	≈	≈	≈	≈	≈	≈	≈	≈	≈







## MORE THAN 35 YEARS OF HIGH QUALITY EXPERIENCE

Ghibson Italia can now boast of more than 35 years of experience in manufacturing of industrial valves.

In these 30 years we have designed and manufactured in our facilities in Italy butterfly valves and check valves, for the most different industrial applications.

We export our products all over the world always providing our customers with the best assistance during all the phases: design, installation, maintenance.

### MARKET SEGMENTS

Marine  
Water Treatment  
Pulp & Paper  
Power Plant  
Nuclear Plant  
HVAC  
Chemical & Petrochemical  
Powder Conveying Systems  
Food & Beverage

### APPLICATIONS

Steam isolation - Vacuum service - Refining  
Cooling Water systems - Metallurgical processes  
Powder transportation & storage  
Oil field recovery - Liquid natural gas  
Steam service - Steam Turbine  
Saltwater Service - District heating & cooling  
Hot Air & Smokes  
Chemicals storage & transportation  
Food & Beverage processes

### DEPARTMENTS

- RESEARCH & DEVELOPMENT
- DESIGN
- CUSTOMIZATION
- PRODUCTION & LOGISTIC
- SALES & MARKETING
- QUALITY CONTROL
- CERTIFICATIONS
- PACKING AND SHIPPING
- AFTER SALES SUPPORT

### WIDE RANGE OF PRODUCTS

Very large choice of materials including valves of every alloy of carbon or stainless steel, bronze, aluminium, as well as with PTFE or Polypropylene.

We manufacture rubber seated valves with many elastomer types (EPDM, NBR, FKM, Silicone, Carboxidate among others), as well as PTFE, RTFE seated valves with many different coatings such as Halar, Rilsan, PFA, Chenisil, etc.

We can offer a total assistance:

- before selling we can start from dimensioning the valves and actuators, make selection of materials for all parts upon knowing the specification, prepare all types of drawings etc.
- after selling we make final documentation, provide installation supervision, undertake commissioning etc.

#### BUTTERFLY VALVES

Rubber Seated  
PTFE Seated  
High Performance  
Damper Valves

#### ACTUATORS & OPTIONS

Pneumatic - Electric - Hydraulic

#### CONTROL SYSTEMS

#### CUSTOMIZED VALVES

#### CHECK VALVES

Disc type  
Swing type  
Dual plate

### CERTIFICATIONS





# GHIBSON valves

*not just valves, but solutions*



## **Ghibson Italia srl**

Via Dozza, 2 40069 Zola Predosa BO Italy  
tel +39 051 835711 [info@ghibson.it](mailto:info@ghibson.it)

[ghibsonvalves.com](http://ghibsonvalves.com)