



aerospace
 climate control
 electromechanical
filtration
 fluid & gas handling
 hydraulics
 pneumatics
 process control
 sealing & shielding



icountPD

Online Particle Detector



ENGINEERING YOUR SUCCESS.

icountPD

The icountPD from Parker represents the most up-to-date technology in solid particle detection.



The design dynamics, attention to detail, and small size of the permanently mounted, on-line particle detector brings a truly innovative product to all industry. The laser based, leading-edge technology is a cost effective market solution to fluid management and contamination control.

3 Versions Available

Standard icountPD is designed for test stand, flushing skids, filter carts and other industrial applications.

icountPDR is designed for mobile equipment or any outside use other than hazardous environment.

icountPDZ is intended for applications that require a Zone II safety such as off-shore platforms or any other hazardous environment.

For Zone I applications the standard icountPD can be used within a NEMA7 enclosure.



icountPDR

Features and benefits of the icountPD include:

- Independent monitoring of system contamination trends.
- Early warning LED or digital display indicators for Low, Medium and High contamination levels.
- Moisture % RH LED indicator (optional).
- Cost effective solution in prolonging fluid life and reducing machine downtime.
- Visual indicators with power and alarm output warnings.
- Continuous performance for dependable analysis.
- Hydraulic, phosphate ester & fuel fluid compatible construction.
- Self diagnostic software.
- Fully integrated PC/PLC integration technology such as:
RS232 and 0-5 Volt, 4-20mA, and CANBUS J1939.

Typical Applications

Mobile Equipment

- Earth Moving Machinery
- Harvesting
- Forestry
- Agriculture

Power Generation

- Wind Turbines
- Gearboxes
- Lubrication Systems

Industrial Equipment

- Production Plants
- Fluid Transfers
- Pulp & Paper
- Refineries

Maintenance

- Test Rigs
- Flushing Stands



icountPD/icountPDR/icountPDZ

Features and Benefits

Diagnostic self check start-up time	5 seconds
Measurement period	5 to 180 seconds
Reporting interval through RS232	0 to 3600 seconds
Digital LED display update time	Every second
Limit relay output	Changes occur +/- 1 ISO code at set limit (Hysteresis ON) or customer set (Hysteresis OFF)
4-20mA output signal	Continuous
Principle of operation	Laser diode optical detection of actual particulates
Reporting codes	ISO 7 – 21, NAS 0 – 12, (AS 00 – 12 contact Parker) Icount will also report less than ISO 7, subject to the statistical uncertainty defined in ISO4406:1999, which is shown in the RS232, reporting results as appropriate e.g “>6”
Calibration	By recognized on-line methods, confirmed by the relevant International Standards Organization procedures
Calibration recommendation	12 months (24 months for icountPDZ)
Performance	+/- 1 ISO Code (dependant on stability of flow)
Reproducibility / Repeatability	Better than 1 ISO Code
Power requirement	Regulated 9 to 40Vdc
Maximum current draw	150mA
Hydraulic connection	icountPD: M16 x 2 hydraulic test points (5/8” BSF for aggressive version) icountPD Z2: Size: 066, Connection: EO 24 cone end
Flow range through the device	40 to 140 ml/min (optimum flow = 60ml/min)
Online flow range via System 20 Inline Sensors	Size 0 = 1.59 to 6.6 gpm - (optimum flow = 3.96 gpm) Size 1 = 6.34 to 26.4 gpm - (optimum flow = 18.5 gpm) Size 2 = 44.9 to 100 gpm - (optimum flow = 66 gpm)
Required differential pressure across Inline Sensors	5.8 psi (0.4 bar) minimum
Viscosity range	10 to 500 cSt, 1 to 500 cSt (icountPD Z2)
Temperature (icountPD)	Operating environment: -4°F to +140°F (-20°C to +60°C) Storage: -40°F to +176°F (-40°C to +80°C) Operating fluid: +32°F to +185°F (0°C to +85°C)
Temperature (icountPD Z2)	Operating environment: -22°F to +140°F (-30°C to +60°C) Storage: -40°F to +176°F (-40°C to +80°C) Operating fluid: +41°F to +176°F (+5°C to +80°C)
Working pressure	30 to 6,000 PSI (2 to 420 bar)
Moisture sensor calibration	±5% RH (over compensated temperature range of +10°C to +80°C)
Operating humidity range	5% RH to 100% RH
Moisture sensor stability	±0.2% RH typical at 50% RH in one year
Certification	IP66 rated (icountPD), IP69K (icountPDZ) EMC/RFI –EN61000-6-2:2001(icountPD), EN6100-6-2:2005 (icountPDZ) EN61000-6-3:2001(icountPD), EN61000-6-3:2007 (icountPDZ)
Materials	Stainless Steel case construction (icountPDZ) Stainless Steel hydraulic block Viton seals, (icountPDZ: fluorocarbon seals)
Dimensions	icountPD: 7.2” x 6.1” x 3.4” (182mm x 155mm x 86mm) icountPD Z2: 10.2” x 4.49” x 4.33” (260mm x 114mm x 110mm)
Weight	icountPD: 2.9 lbs. (1.3 kg), icountPDZ: 5.73 lbs. (2.6 kg)
Default Settings	See table on page 39

icountPD

Dimensions / Installation Details

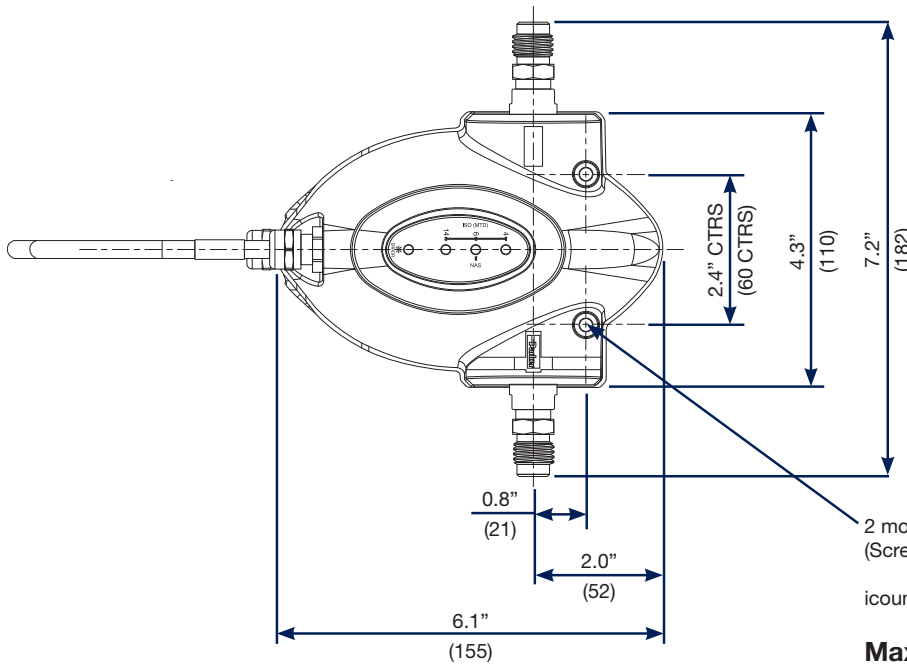
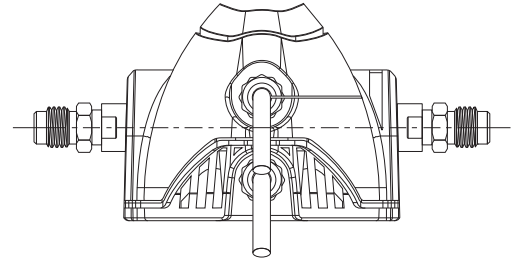
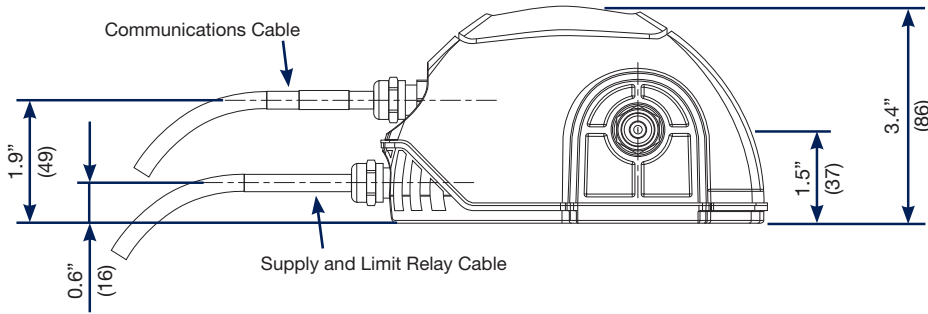

2 mounting locations to suit M5 socket head cap screw.
(Screw pack supplied with icountPD)

icountPD flange thickness = 0.4" (10mm)

Maximum Torque 5Nm

dimensions in inch (mm)

*Limit Relay Wiring Instructions

NORMALLY OPEN
NORMALLY CLOSED
COMMON

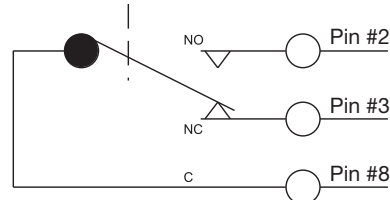

icountPD

Variable mA Output Settings

The following table can be used to equate the analog output for channels A, B, and C independently.

Example: ISO code 12 is equal to 10mA.

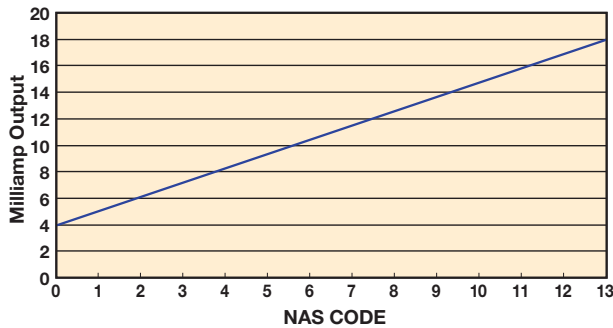
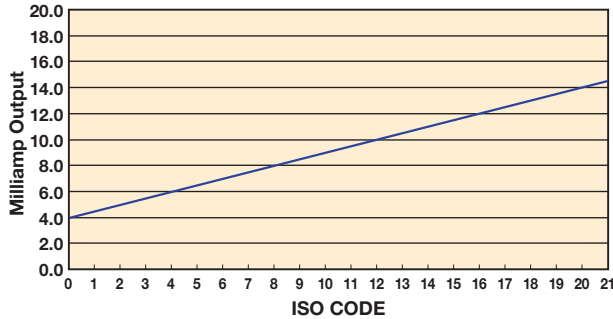

mA	ISO
4.0	0
4.5	1
5.0	2
5.5	3
6.0	4
6.5	5
7.0	6
7.5	7
8.0	8
8.5	9
9.0	10
9.5	11
10.0	12
10.5	13
11.0	14
11.5	15
12.0	16
12.5	17
13.0	18
13.5	19
14.0	20
14.5	21
15.0	**
15.5	**
16.0	**
16.5	**
17.0	**
17.5	**
18.0	**
18.5	**
19.0	OVERRANGE
19.5	OVERRANGE
20.0	ERROR

mA	NAS
4	00
5	0
6	1
7	2
8	3
9	4
10	5
11	6
12	7
13	8
14	9
15	10
16	11
17	12
18	**
19	**
20	ERROR

4-20mA output settings

ISO Setting

mA current = (ISO Code / 2) + 4

eg. 10mA = (ISO 12 / 2) + 4

or

ISO Code = (mA current - 4) * 2

eg. ISO 12 = (10mA - 4) * 2

NAS Setting

mA current = NAS Code + 5

eg. 15mA = NAS 10 + 5

or

NAS Code = mA current - 5

eg. NAS 10 = 15mA - 5

Variable Voltage Output Settings

The variable voltage output option has the capability of two different voltage ranges: a 0-5Vdc range as standard, and a user-selectable 0-3Vdc range.

The full list of commands on how to change the voltage output is available from Parker.

The following tables can be used to relate the analog output to an ISO or NAS code.

For example, in a 0-5Vdc range, ISO code 16 is equal to an output of 3.5Vdc. In a 0-3Vdc range, ISO code 8 is equal to an output of 1.0Vdc.

Table relating ISO codes to voltage output

ISO	Err	0	1	2	3	4	5	6	7	8	9	10	11
0-5Vdc	<0.2	0.3	0.5	0.7	0.9	1.1	1.3	1.5	1.7	1.9	2.1	2.3	2.5
0-3Vdc	<0.15	0.2	0.3	0.4	0.5	0.6	0.7	0.8	0.9	1.0	1.1	1.2	1.3

ISO	12	13	14	15	16	17	18	19	20	21	22	Err
0-5Vdc	2.7	2.9	3.1	3.3	3.5	3.7	3.9	4.1	4.3	4.5	4.7	>4.8
0-3Vdc	1.4	1.5	1.6	1.7	1.8	1.9	2.0	2.1	2.2	2.3	2.4	>2.45

Table relating NAS codes to voltage output

ISO	Err	00	0	1	2	3	4	5	6	7	8	9	10	11	12	Err
0-5Vdc	<0.4	0.6	0.9	1.2	1.5	1.8	2.1	2.4	2.7	3.0	3.3	3.6	3.9	4.2	4.5	>4.6
0-3Vdc	<0.2	N.S.	0.3	0.5	0.7	0.9	1.1	1.3	1.5	1.7	1.9	2.1	2.3	2.5	2.7	>2.8

icountPD

Display Parameters (ISO 4406/NAS 1638)

Digital display indication

The digital display will show the actual measured codes, the channel (μ) size and the user definable limits. Visible display of the channel size and user definable limits will alternate.

The moisture sensor reading (%RH) will also be shown – if the moisture sensor option is fitted.

The order of trigger for both of the codes and moisture sensor option is:

- Solid digit(s) = code(s) that are at or below the set point (limit)

- Flashing digit(s) = code(s) that are above the set point (limit)

The display for ISO4406 and NAS1638 are identical. The ISO display is shown below.



LED display indication

The LED display uses 3 sets of LED for the indication of ISO 4406 and NAS1638 code figures. Individual code lights will trigger based on the customer settings.

The order of trigger will be:

- Solid green = one ISO code, or better, below the set point (limit)
- Blinking green = ISO code at the set point (limit)
- Solid red = one ISO code above the set point (limit)
- Blinking red = two ISO codes, or more, above the set point (limit)

Moisture sensor output settings

The moisture sensor is an option that can be included when specifying the icountPD. The moisture sensor reports on the saturation levels of the fluid passing through the icountPD sensing cell. The output is a linear scale, reporting within the range of 5% saturation to 100% saturation.

Saturation	4-20mA	0-3Vdc	0-5Vdc
5%	4.8	0.15	0.25
25%	8	0.75	1.25
50%	12	1.50	2.50
75%	16	2.25	3.75
100%	20	3.00	5.00

icountPD

Auxiliary Flow Device

This simple to use flow control device fits on the downstream (outlet) side of the icountPD and is fitted with a differential pressure valve that adjusts the system flow to a range inside the icountPD specifications.

The flow control device will operate correctly between 150 psi (10.3 bar) and 2900 psi (200 bar) and the return back to an open system of 0 psi (0 bar) (DP = 2900 psi, 200 bar).



P/N ACC6NN019

Optional Accessories					
Description	Part Number		IPD	IPDR	IPDZ
	Mineral/Fuel	Phosphate Esters			
1 Meter Hose Length	ACC6NN001	ACC6NN002	X		
2 Meter Hose Length	ACC6NN003	ACC6NN004	X		
5 Meter Hose Length	ACC6NN005	ACC6NN006	X		
1/4" BSP Test point	ACC6NN007	ACC6NN008	X		
1/8" BSP Test point	ACC6NN009	ACC6NN010	X		
1/8" NPT Test point	ACC6NN011	ACC6NN012	X		
Single Point Sampler	SPS2021	SPS2061	X	X	X
US Power Supply	ACC6NE010		X	X	X
European Power Supply	ACC6NN013		X	X	X
5 meter, M12, 8-pin plug and socket cable kit*	ACC6NN014	ACC6NN015	X		
Deutsch 12-pin connector kit	ACC6NN016		X	X	
RS232 to USB converter	ACC6NN017		X	X	X
12" long M12 8-way RS232 & power cable kit	ACC6NN018		X		X
External Flow Device	ACC6NN019		X	X	X
M12, 12 way cable	ACC6NN024			X	

* Cable Kit consists of two 5 meter cables to enable all output options (Communications cable and Relay/Power Supply cable).

icountPDZ

ATEX Approved Online Particle Detector



For use in explosive and hazardous areas

The icountPD Particle Detector from Parker represents the most up to date technology in solid particle contamination analysis. This compact, permanently mounted laser-based ATEX approved particle detector module is designed for use in Zone II areas and is housed in a robust Stainless Steel IP69K approved enclosure that provides a cost effective solution to fluid management and contamination control.



Product Features:

- Independent monitoring of system contamination trends.
- Assembled in an approved and certified Stainless Steel enclosure to comply with ATEX Directive 94/9/EC.
- Can be used in explosive and hazardous areas.
- ATEX Zone II.
- Certified to CE Ex II 3GD, Ex nA IIC T4 Gc, Ex tc IIIC Dc SIRA 09ATEX4340X and IECEx SIR 09.0137X (-30°C < Ta < +60°C).
- Moisture & %RH indicator (optional).
- Warning limit relay outputs for low, medium and high contamination levels.
- Continuous performance for prolonged analysis.
- Self diagnostic software.
- Full PC/PLC integration technology such as:- RS232 and 0-5Volt, 4-20mA, CAN(J1939) (Contact Parker for other options).
- Set up and Data logging support software included.

icountPD

Ordering Information

BOX 1	BOX 2	BOX 3	BOX 4	BOX 5	BOX 6	BOX 7	BOX 8
IPD	1	2	2	2	2	1	30

BOX 1: Basic Assembly	
Symbol	Description
IPD	Standard Particle Detector
IPDR	Particle Detector - Robust Construction
IPDZ	Particle Detector - Hazardous (Zone 2)

BOX 5: Limit Relay	
Symbol	Description
1	No (iPDR only)
2	Yes

BOX 2: Fluid Type ^{1,2}	
Symbol	Description
1	Mineral Oil
2	Phosphate Ester (iPD, iPDR only)
3	Aviation Fuel (4 channel) (iPD, iPDZ only)

BOX 6: Communication ^{3,4}	
Symbol	Pressure Setting
2	RS232 / 4-20mA
3	RS232 / 0-5V (iPD, iPDR only)
5	RS232 / CAN-bus (J1939)

BOX 3: Calibration	
Symbol	Description
2	MTD

BOX 7: Moisture	
Symbol	Description
1	No
2	Yes

BOX 4: Display	
Symbol	Description
1	None (iPDR, iPDZ only)
2	LED (iPD only)
3	Digital (iPD only)

BOX 8: Cable Connector ⁵	
Symbol	Description
10	Deutsch DT Series (iPD, iPDR only)
30	M12, 8-pin plug connector (iPD, iPDZ only)
40	M12, 12-pin plug connector (iPDR only)

Standard Default Settings for all icountPDs	
Comms echo	OFF
Verbose errors	OFF
STI Sensors used	OFF
Reporting standards	ISO
Particle limits	19/18/15
Measurement period	60 seconds
Reporting interval	30 seconds
Power-on mode	AUTO
Auto start delay	5 seconds
Date Format	dd/mm/yy
Default if Options Fitted	
Relay hysteresis	ON
Relay operation for particle limits	ON
Relay operation for moisture sensor limits	ON
Digital display orientation	0 degrees
Digital display brightness level	3-mid
0-5V/0-3V output voltage range	0-5V
Moisture sensor limit	70%

Notes:

- When "3" is selected in Box 2, "1" must be selected in Box 7.
- Aviation Fuel option can also be used for diesel fluids.
- For iPD and iPDR units, when "5" is selected in Box 6, "10" must be selected in Box 8.
- Contact Parker for additional communication options (RS485, GPRS, LAN, WiFi, Sat, etc.)
- The required connecting cables are available as a kit. The kit consists of two 5 meter cables (Communications cable and Relay/Power Supply cable) to enable all output options. See Accessory table on page 7 for applicable part number.

