



aerospace
climate control
electromechanical
filtration
fluid & gas handling
hydraulics
pneumatics
process control
sealing & shielding



Marine Filtration Systems



ENGINEERING YOUR SUCCESS.

Table of Contents

Troubleshooting Guide	3
SNAPP Fuel Filter Water Separator	4
Turbine Series.....	5-9
Diesel Spin-on Series	10-11
Fuel Conditioning Module.....	12
Filter Funnels	12
Gasoline Spin-on Series	13-14
High Capacity Fuel Filtration.....	15
Fuel Dispensing/Polishing	16-17
Crankcase Filtration (CCV Systems).....	18-20
Air Filters/Silencers	19-21
Fuel/Air Separators (Lifeguard).....	22
Parker Marine Hose	23
Water Detection Probes & Modules	24-25
Accessories	26
Product Information.....	27

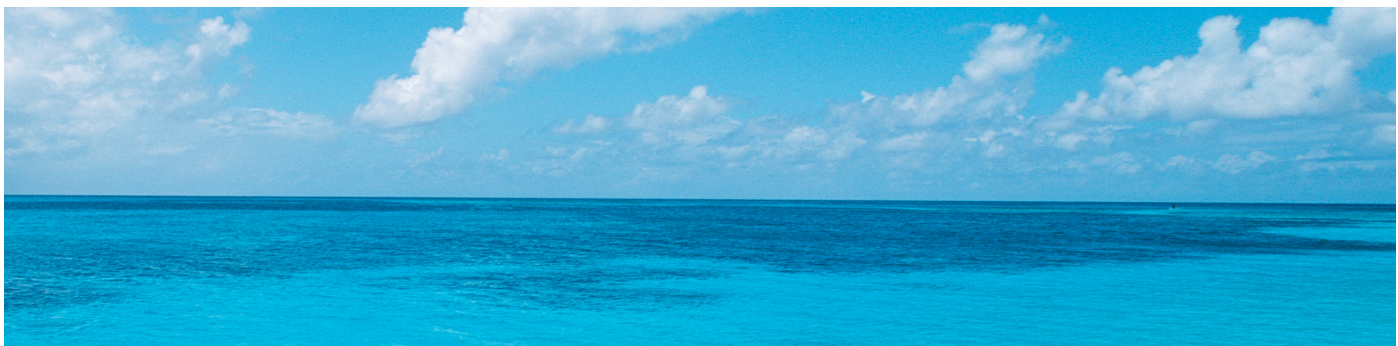

If It's Not A Genuine Racor Filter, you could be asking for trouble...

Issue	Concerns With Competitor Copies	Racor Commitment to Quality
Blocked Filter	Low quality media will perform poorly and can block 70% sooner than Racor media.	Racor uses propriety Aquabloc® Synergy media that meets or exceeds water removal and particle efficiency requirements for OEM fuel injection systems.
Bypassing	Poorly constructed filters may bypass internally allowing dirty fuel and water to reach the engine.	Racor uses high quality materials and production processes to ISO/TS16949 to eliminate bypass problems.
Split Or Leaking Seals	Poor quality seals will swell excessively, leak, and may deteriorate within the service period.	Racor uses high quality automotive grade gaskets and seals that are compatible with B20 bio-diesel.
Dirty Fuel Reaching Engine	Inefficient filters will not protect the engine.	Racor replacement filters will perform as designed for the application.
Water In Fuel Reaching Engine	Very few, if any, copycat filters perform to original equipment specifications.	Racor uses the same media and materials in original equipment and replacement filters.
Cracked Head Casting	Poor quality head castings cannot cope with extreme environmental conditions and vibrations.	Racor products are validated under extreme vibration and climatic conditions.
Contains Banned Substances	Some copy filters contain banned substances in the canister coating and plating.	Racor canisters do not contain banned substances and are validated under extreme salt spray and climatic conditions.
Cracked Clear Bowl	Copycat filter bowls are often made from poor quality material that will crack under extreme temperature, chemical exposure, or continuous vibrations.	Racor uses a unique durable clear plastic bowl material with high clarity, excellent UV protection, low and high temperature resistance, is impact resistant, and is impervious to all fuel types.
Filter Accessories	Unauthorized Racor copies do not always offer accessories. If they do, they are likely not tested.	Racor has a wide range of filter accessories that are validated for integrity, EMC compatibility, and safety.

SNAPP. The fuel filter change that changes everything.

SNAPP is big protection for small gasoline or diesel engines with fuel flows up to 40 gph and makes every filter change literally a snap. Fast, easy, clean. No tools are needed – when it's time for service, simply snap in a new filter. Simple installation and a patented priming system mean that protecting your engine investment is now ... a SNAPP.



Fast, easy, clean, SNAPP is a fuel filter change for the better.

The world turns to Racor for filtration solutions that provide ultimate protection from water and solid contamination. This is filtration that includes two innovations often copied but never quite duplicated – the powerful protection of patented, world-class Aquabloc® Synergy filter media and, the Racor trademark, a clear bowl that allows for at-a-glance inspection of fuel integrity.



Quick-release squeeze tabs make filter changes a snap.

Permanent mounting bracket is stainless steel for withstanding corrosive environments.

SNAPP is a one-piece fuel filter water separator for 24/7 protection.

Heavy-duty high-impact nylon construction won't ever rust or corrode, even in humid conditions.

Clear bowl for at-a-glance inspection.

The rugged clear bowl allows on-the-spot inspection for water in fuel – a significant advantage when troubleshooting fuel quality.

The Racor self-venting drain means easy service with no mess – twist, drain, done.

Legendary Aquabloc® Synergy filter media in 2, 10 or 30 micron rating.

The Aquabloc® Synergy media is the world's definitive filtration protection – it's 99% effective in separating water and solid contamination from marine and diesel fuels.



Part #	Description
23281-02	Fuel Filter with Bracket - 2 Micron
23281-10	Fuel Filter with Bracket - 10 Micron
23281-30	Fuel Filter with Bracket - 30 Micron
R23280-02	Fuel Filter - Service - 2 Micron
R23280-10	Fuel Filter - Service - 10 Micron
R23280-30	Fuel Filter - Service - 30 Micron
23299-02	Fuel Filter with Bracket - with Drain - 2 Micron
23299-10	Fuel Filter with Bracket - with Drain - 10 Micron
23299-30	Fuel Filter with Bracket - with Drain - 30 Micron
R23298-02	Fuel Filter - Service - with Drain - 2 Micron
R23298-10	Fuel Filter - Service - with Drain - 10 Micron
R23298-30	Fuel Filter - Service - with Drain - 30 Micron

Part #	SNAPP Fittings
RK23319	90° Quick-Connect Fitting Kit, 3/8" x 3/8"
RK23320	Straight Quick-Connect Fitting Kit, 3/8" x 5/16"
RK23321	90° Quick-Connect Fitting Kit, 3/8" x 5/16"

Specifications	
Maximum Flow Rate - Gasoline	2 micron - 40 gph (151 lph)
	10 micron - 34 gph (129 lph)
	30 micron - 26 gph (100 lph)
Maximum Flow Rate - Diesel	2 micron - 26 gph (100 lph)
	10 micron - 26 gph (100 lph)
	30 micron - 26 gph (100 lph)
Micron Rating	2, 10, or 30 micron
Height	7.8" (198 mm)
Width	3.8" (97 mm) at bracket
Depth	4.1" (104 mm)
Water Sump Capacity	3.4 oz. (100 ml)
Bracket Material	Stainless Steel
Port Size	3/8" (9.5 mm)
Quick-Connect Fittings	3/8" (9.5 mm) (per SAE J2044)
Rated Pressure	50 PSI (3.5 bar)
Water Removal Efficiency	99%
Rated Temperature Range	-20° to 150°F (-29° to 66°C)

Fuel Filtration



Duplex units offer mariners the peace-of-mind of having a clean filter in reserve. Rough seas can stir up tank sediment which will quickly clog a single fuel filter.

With Racor, a simple turn of a valve puts a clean filter back on-line. Servicing of the clogged filter can then be performed even with the engine running.



Legendary Diesel Fuel Filtration

When engines demand heavy-duty, high-capacity water separation and fuel filtration, the Turbine Series is the most complete, efficient, and reliable engine protection you can install. Symbolizing Racor's continuing commitment to the science of filtration, the Turbine Series has established its position as the filter/separator often imitated, but never equaled. Models that include an aluminum bowl or stainless steel shield are UL-listed, American Bureau of Shipping, and USCG accepted. For severe service, all-metal bowls should be specified.

Paired with our famous and genuine Aquabloc® Synergy filters, the Racor Turbine Series is still the preferred brand for serious sailors globally.

Make certain that you replace your Turbine Series assemblies only with Genuine Racor Aquabloc® Synergy filters. While many others try to imitate the construction and performance of Aquabloc® Synergy filters, only the genuine article delivers the fit and performance specified by engine manufacturers, and guarantees that your Racor filter/water separator will deliver the protection you count on.

For convenience, end-caps are color-coded for easy identification and application.

- Red = 30 micron, primary filtration.
- Blue = 10 micron, secondary filtration.
- Brown = 2 micron, final filtration.

The top cap includes handles for easy servicing and a filter bypass button for emergencies.

Aquabloc® Synergy media is a blend of high-grade cellulose compounded with engineered fibers, and a special chemical treatment.



Aquabloc® Synergy Filters

Besides removing asphaltenes, water, gums, and varnishes, Aquabloc® Synergy filters out tiny particles of dirt and algae from diesel fuel. Aquabloc® Synergy filters have polymer end-caps that will not corrode, ever.

With an Aquabloc® Synergy replacement filter, you get a complete kit with all the seals you need. And not just any seals, but specially-formulated, Racor-engineered seals.

Always carry extra Racor fuel filters as one tankful of dirty fuel can quickly clog a filter.

Many Racor filters include an emergency bypass.

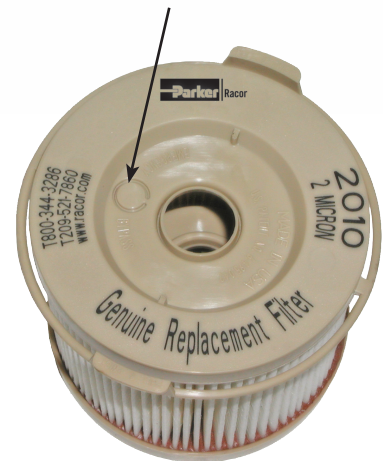

The Inside Story

1 As fuel enters, it moves past the internal check valve, then through the turbine centrifuge where it flows in a spiraling direction, spinning off large particulates and water droplets. Being heavier than fuel, the large particulates and water droplets fall to the bottom of the bowl.

2 Smaller water droplets bead-up along and on the sides of the internal components and on the surface of the Aquabloc® Synergy filter. When large enough, they too fall into the high-capacity bowl to be drained as needed.

3 Besides repelling water, asphaltenes, algae, rust, and tiny solids from fuel. Aquabloc® Synergy filters are waterproof, so they remain effective longer, saving you money.

Order only genuine Aquabloc® Synergy replacement filters.

2010	TM	-OR
Select Filter 2010 (500 Series),	Select a Micron Rating SM = 2, TM = 10, or PM = 30	Must have " -OR " in part number (includes o-rings)

2020V	10
Select Filter, 2040V (900 Series), or 2020V (1000 Series)	Select a Micron Rating 2, 2LL, 10, or 30

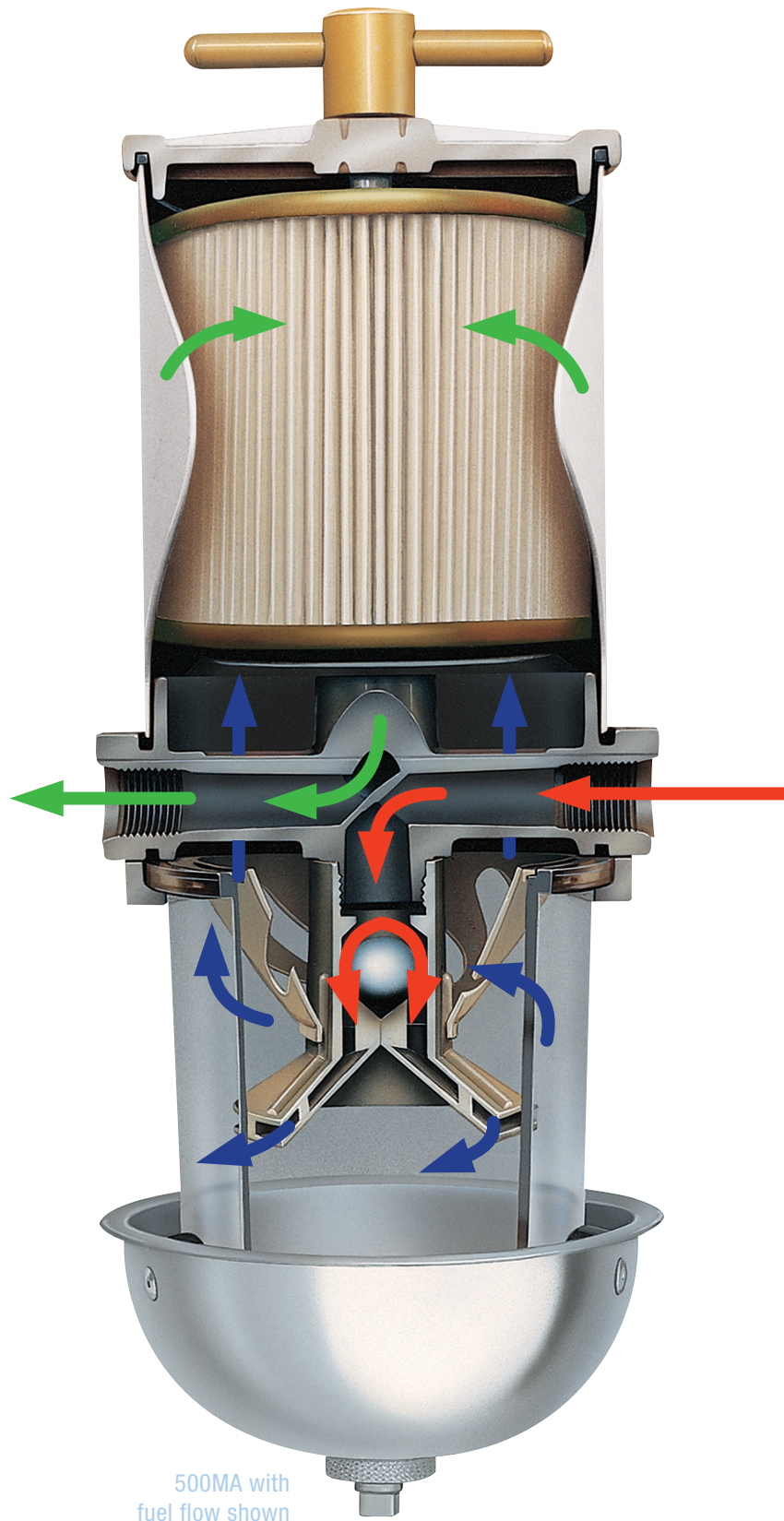

Electric Primer Pump Kit

Racor's electric primer pump kit can be retrofitted to many of the Racor 900 or 1000 Turbine Series fuel filters/water separators already in service.

The filter pump is an innovative and proprietary system consisting of a 100 micron pre-screen filter, a flow bypass circuit, and an innovative roller cell pump powered by a 12 or 24 vdc Racor brushless motor.

When the switch is activated the fuel is drawn into the pre-screen, then pumped through the housing, refilling the unit with fresh, clean, dry fuel.

When not in use, the filter pump system is bypassed and the Racor fuel filter/water separator functions normally.



The complete primer pump kit includes a wiring harness and controller switch.

Order Part Number:

- **RKP1912** for 12 vdc systems
- **RKP1924** for 24 vdc systems

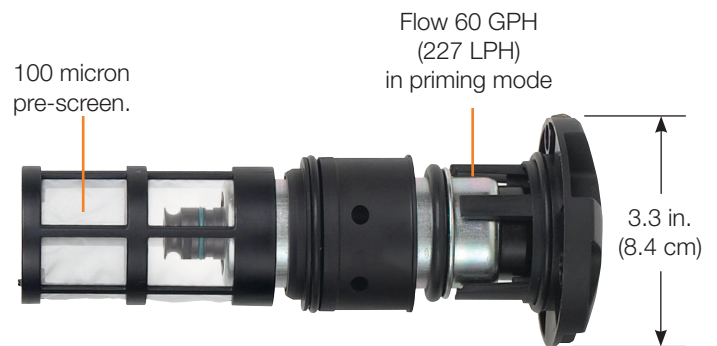

The unitized assembly is only 3.3 in. (8.4 cm) tall and kit is easily retrofitted to a 900 or 1000 series filter. For Racor duplex or triplex filter systems, only one primer pump is needed.

Note: Do not use in continuous duty applications.

Marine Turbine Series Fuel Filters



Model	500MA2/ 10/ 30	900MA2/ 10/ 30	1000MA2/ 10/ 30	75500MAX2/ 10/ 30	75900MAX2/ 10/ 30
Max. Flow Rate (One filter on-line) (Two filters on-line)	60 GPH (227 LPH) N/A	90 GPH (341 LPH) N/A	180 GPH (681 LPH) N/A	60 GPH (227 LPH) 120 GPH (454 LPH)	90 GPH (341 LPH) 180 GPH (681 LPH)
Height	11.5 in. (29.2 cm)	17.0 in. (43.2 cm)	22.0 in. (55.9 cm)	11.5 in. (29.2 cm)	17.0 in. (43.2 cm)
Width	5.8 in. (14.7 cm)	6.0 in. (15.2 cm)	6.0 in. (15.2 cm)	14.5 in. (36.8 cm)	18.8 in. (47.8 cm)
Depth	4.8 in. (12.2 cm)	7.0 in. (17.8 cm)	7.0 in. (17.8 cm)	9.5 in. (24.1 cm)	11.0 in. (27.9 cm)
Weight (approx.)	4 lbs (1.8 kg)	6 lbs (2.7 kg)	17 lbs (7.7 kg)	17 lbs (7.7 kg)	23 lbs (10.4 kg)
Port Size (metric optional) ¹	3/4"-16 SAE 16 mm x 1.5	7/8"-14 SAE 22 mm x 1.5	7/8"-14 SAE 22 mm x 1.5	3/4"-16 SAE N/A	7/8"-14 SAE N/A
Clean Pres. Drop	0.3 PSI (0.02 bar)	0.34 PSI (0.02 bar)	0.49 PSI (0.03 bar)	0.70 PSI (0.05 bar)	1.7 PSI (0.12 bar)
Max. Operating Pressure ²	15 PSI (1.03 bar)	15 PSI (1.03 bar)	15 PSI (1.03 bar)	15 PSI (1.03 bar)	15 PSI (1.03 bar)
Replacement Filter	2010 Series	2040 Series	2020 Series	2010 Series	2040 Series
Overhead Clearance	4.0 in. (10.2 cm)	5.0 in. (12.7 cm)	10.0 in. (25.4 cm)	4.0 in. (10.2 cm)	5.0 in. (12.7 cm)
Ambient Temperature Range	-40° to +255°F (-40° to +124°C)				
Maximum Fuel Temperature	190°F (88°C)				

Notes: Units are available with metal bowls, add "M" after MA, i.e. 1000MAM. ¹ Use (*) for metric port threads, i.e. *500MA, *900MA, and *1000MA. ² Vacuum installations are recommended.

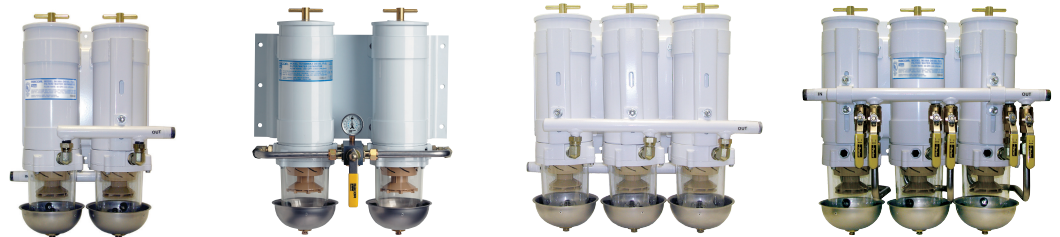

Model	731000MA2/ 10/ 30	751000MAX2/ 10/ 30	771000MA10	791000MAV2/ 10/ 30
Max. Flow Rate (One filter on-line) (Two filters on-line) (Three filters on-line)	N/A 360 GPH (1363 LPH) N/A	180 GPH (681 LPH) 360 GPH (1363 LPH) N/A	N/A N/A 540 GPH (2044 LPH)	180 GPH (681 LPH) 360 GPH (1363 LPH) 540 GPH (2044 LPH)
Height	22.0 in. (55.9 cm)	22.0 in. (55.9 cm)	22.0 in. (55.9 cm)	22.0 in. (55.9 cm)
Width	16.5 in. (41.9 cm)	18.0 in. (45.7 cm)	18.0 in. (45.7 cm)	21.5 in. (54.6 cm)
Depth	12.0 in. (30.5 cm)	11.0 in. (27.9 cm)	11.0 in. (27.9 cm)	11.8 in. (30.0 cm)
Weight (approx.)	26 lbs (11.8 kg)	30. lbs (13.6 kg)	39 lbs (17.7 kg)	52 lbs (23.6 kg)
Port Size	3/4"-14 NPT	7/8"-14 SAE	1"-11.5 NPT	3/4"-14 NPT
Clean Pres. Drop	1.7 PSI (0.12 bar)	3.7 PSI (0.26 bar)	1.7 PSI (0.12 bar)	2.5 PSI (0.17 bar)
Max. Operating Pressure ³	15 PSI (1.03 bar)	15 PSI (1.03 bar)	15 PSI (1.03 bar)	15 PSI (1.03 bar)
Replacement Filter	2020 Series	2020 Series	2020 Series	2020 Series
Overhead Clearance	10.0 in. (25.4 cm)	10.0 in. (25.4 cm)	10.0 in. (25.4 cm)	10.0 in. (25.4 cm)
Ambient Temperature Range	-40° to +255°F (-40° to +124°C)			
Maximum Fuel Temperature	190°F (88°C)			

Notes: Units are available with metal bowls, add "M" after MA, i.e. 1000MAM. ³ Vacuum installations are recommended.

Compact and Versatile Systems for Main Propulsion and Genset Applications

Cost-Effective

Cost-effective designs for on-engine or remote mounting. Complete assemblies available in all-metal bowls.

High-Capacity

Hand-operated fuel priming pumps are integral to many Racor diesel spin-on series models, a feature that allows for removal of unwanted air from the filter and engine fuel system.

Environmentally Friendly

Metal bowls are reusable, impact-resistant, and ready for the real world. When it's time for service, only the filter is replaced—the bowl and drain plug are reused. The long life-cycle of Racor bowls saves you money and reduces the environmental impact through disposal of less material.

Note: Use metal bowl versions for all marine engine room applications.

Easy Upgrades

Water-in-fuel (WIF) sensors are available to alert operators to drain accumulated water from the bowl.

Corrosion-Resistant Construction

Advanced technology means bowls will not deteriorate from water collection, alcohol-blended fuels, exposure to harsh additives, salt spray, or UV light.

Safety First

Racor's UL-listed filters meet ABYC, ASTM, ISO, and many other global standards for filters used in marine engine rooms.

Diesel Spin-on Series

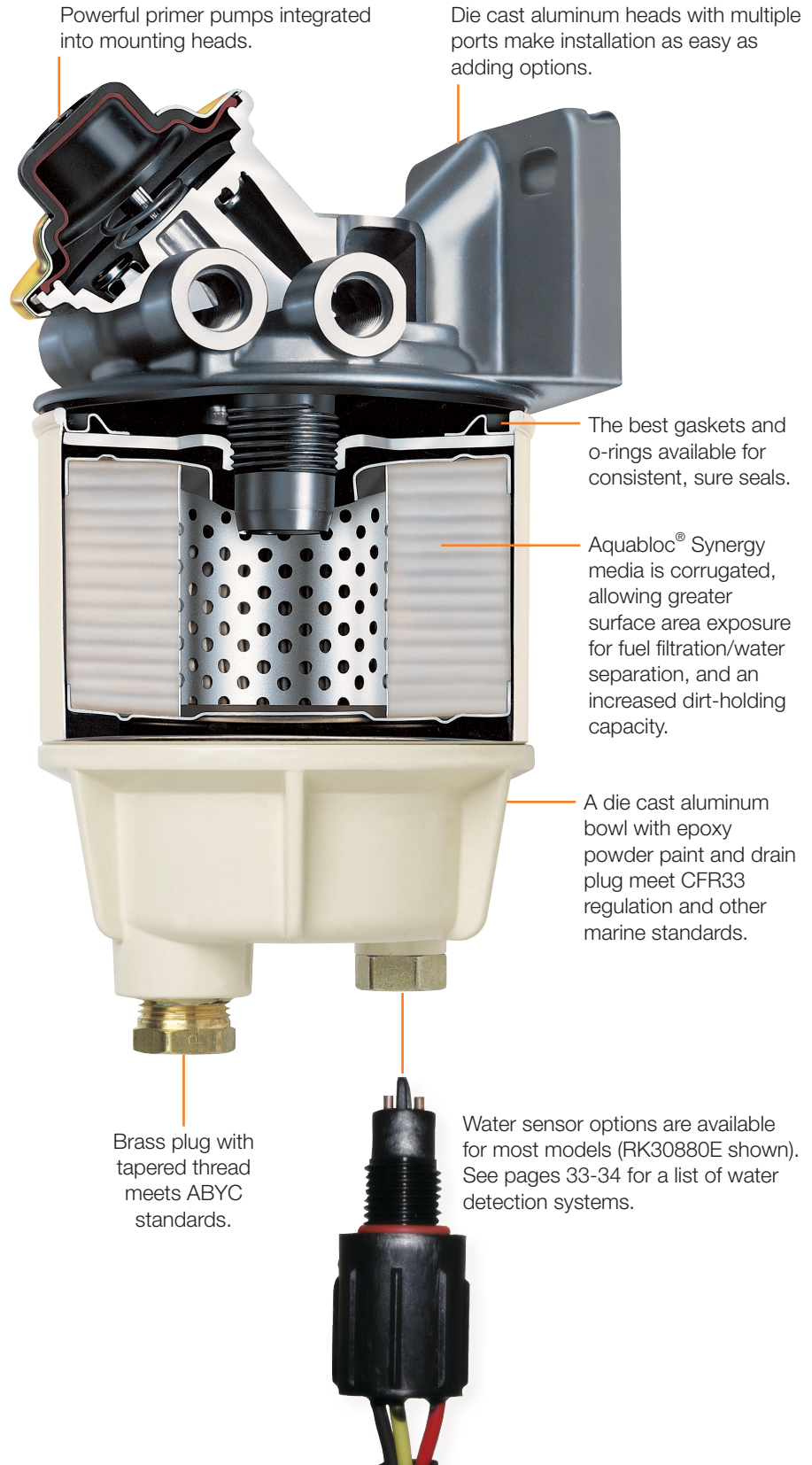

Diesel Spin-on Filters

Please specify carefully – there are important differences among Spin-On Series features which effect performance and application.



Specifications	120RMAM2	120RMAM30	215RMAM	230RMAM	245RMAM
Maximum Flow Rate	15 GPH (57 LPH)	15 GPH (57 LPH)	15 GPH (57 LPH)	30 GPH (114 LPH)	45 GPH (170 LPH)
Maximum PSI ¹	7 PSI (0.5 bar)	7 PSI (0.5 bar)	30 PSI (2.1 bar)	30 PSI (2.1 bar)	30 PSI (2.1 bar)
Clean Pressure Drop	0.15 PSI (0.01 bar)	0.15 PSI (0.01 bar)	0.12 PSI (0.01 bar)	0.3 PSI (0.02 bar)	0.6 PSI (0.04 bar)
Port Size	1/4"-18 NPTF	1/4"-18 NPTF	1/4"-18 NPTF	1/4"-18 NPTF	1/4"-18 NPTF
Primer Pump	No	No	Yes	Yes	Yes
Replacement Filter	R12SUL	R12PUL	R15TUL	R20TUL	R25TUL
Number of Ports	4 2 - Inlet 2 - Outlet	4 2 - Inlet 2 - Outlet	3 1 - Inlet 2 - Outlet	3 1 - Inlet 2 - Outlet	3 1 - Inlet 2 - Outlet
Water Sensor Option	RK30880E or RK23191 (Stainless Steel - UL Listed/ABS Marine Type Approved)				
Height	5.7 in. (14.5 cm)	5.7 in. (14.5 cm)	7.7 in. (19.6 cm)	9.0 in. (22.9 cm)	10.5 in. (26.7 cm)
Width	3.2 in. (8.1 cm)	3.2 in. (8.1 cm)	3.9 in. (9.9 cm)	3.9 in. (9.9 cm)	4.0 in. (10.2 cm)
Depth	3.2 in. (8.1 cm)	3.2 in. (8.1 cm)	4.0 in. (10.2 cm)	4.0 in. (10.2 cm)	4.0 in. (10.2 cm)
Weight (approx.)	1.4 lb (0.6 kg)	1.4 lb (0.6 kg)	1.2 lbs (0.5 kg)	2.0 lbs (0.9 kg)	2.2 lbs (1.0 kg)
Ambient Temp Range	-40° to +255°F (-40° to +124°C)				
Maximum Fuel Temp	190°F (88°C)				

Please specify carefully – there are important differences among Spin-On Series features which effect performance and application.



Specifications	445MAM10	460MAM10	490MAM10	4120MAM30
Maximum Flow Rate	45 GPH (170 LPH)	60 GPH (227 LPH)	90 GPH (341 LPH)	120 GPH (454 LPH)
Maximum PSI ¹	15 PSI (1.0 bar)	15 PSI (1.0 bar)	15 PSI (1.0 bar)	15 PSI (1.0 bar)
Clean Pressure Drop	0.2 PSI (0.01 bar)	0.3 PSI (0.02 bar)	0.4 PSI (0.03 bar)	0.5 PSI (0.03 bar)
Port Size	3/8" NPTF	3/8" NPTF	3/8" NPTF	3/4" SAE
Primer Pump	Yes	Yes	Yes	Yes
Replacement Filter	S3204TUL	S3211TUL	S3201TUL	S3201PUL
Number of Ports	4 2 - Inlet 2 - Outlet	4 2 - Inlet 2 - Outlet	4 2 - Inlet 2 - Outlet	4 2 - Inlet 2 - Outlet
Water Sensor Option	RK30880E			
Height	9.4 in. (23.9 cm)	10.8 in. (27.4 cm)	12.8 in. (32.5 cm)	12.8 in. (32.5 cm)
Width	4.5 in. (11.4 cm)	4.5 in. (11.4 cm)	4.5 in. (11.4 cm)	4.5 in. (11.4 cm)
Depth	4.8 in. (12.2 cm)	4.8 in. (12.2 cm)	4.8 in. (12.2 cm)	4.8 in. (12.2 cm)
Weight (approx.)	2.9 lbs (1.3 kg)	3.1 lbs (1.4 kg)	3.3 lbs (1.5 kg)	3.3 lbs (1.5 kg)
Ambient Temp Range	-40° to +255°F (-40° to +124°C)			
Maximum Fuel Temp	190°F (88°C)			

¹ Pressure Installations are applicable up to the maximum PSI shown, vacuum installations are recommended.

Racor Aquabloc® Synergy Spin-on Fuel Filters Are Available in Color Coded 2, 10, or 30 Micron Ratings.

- P** = 30 micron, primary filtration.
- T** = 10 micron, secondary filtration.
- S** = 2 micron, final filtration.

Aquabloc® Synergy Spin-on Fuel Filters

Besides removing asphaltenes, water, gums, and varnishes, Aquabloc® Synergy filters out tiny particles of dirt and algae from diesel fuel.

With an Aquabloc® Synergy replacement filter, you get a complete kit with all the seals you need. And not just any seals, but specially-formulated, Racor-engineered seals.

Always carry extra Racor fuel filters as one tankful of dirty fuel can quickly clog a filter.



Fuel Conditioning Module



Product Specifications

Max. Flow Rate	60 GPH (220 LPH)
No. of Ports	2 1 - Inlet 1 - Outlet
Port Size	M16-1.5 ORB
Water Sensor	Standard
Micron Rating	10
Operating Voltage	12V and 24V

Available Part Numbers

P510MAM	FF/WS, 10 micron
R58065-2	2 micron Replacement Element
R58065-10	10 micron Replacement Element
R58065-30	30 micron Replacement Element
RK 20725	12V Water Detection
RK 20725-24	24V Water Detection
RK 12870	12V Water Detection w/ Buzzer



The New Racor Fuel Polisher removes contamination at the source - the fuel tank.

Most filtration solutions block contamination as it moves through the fuel system on the way to the engine.

As contamination builds, fuel filters will choke leading to inadequate fuel delivery to the engine, damage to injectors and other engine components, increased emissions, and decreased performance.

The Racor fuel polisher removes contamination from the fuel tank allowing the fuel system to run at peak performance.

By setting up a new fuel circuit around the fuel tank contaminates such as water, dirt and rust will be removed from the fuel delivery circuit, resulting in increased filter life, better performance, and less downtime to change filters.

Filter Funnels

Racor Filter Funnel (RFF) is a heavy-duty, fast-flow, filter-in-a-funnel that separates damaging free water and contaminants from gasoline, diesel, heating oil, and kerosene.

The RFF family of products is capable of removing free water and solids down to 50 micron and allows you to visually inspect the integrity of your fuel supply as you refuel.

The RFF family is manufactured using industrial-grade black electro-conductive polypropylene. Carbon powder is injected into the plastic so that the RFF will conduct static electricity. The grounding capability of the RFF is an important safety feature. Always use proper fuel handling procedures and follow local, state, and federal regulations.



Specifications	RFF1C	RFF3C	RFF8C	RFF15C
Max. Flow Rate	2.5 GPM (9.4 LPM)	3.5 GPM (13.2 LPM)	5 GPM (18.9 LPM)	12 GPM (45.4 LPM)
Micron Rating	50 micron	50 micron	50 micron	50 micron
Height	6.0 in. (15.2 cm)	9.0 in. (22.9 cm)	10.0 in. (25.4 cm)	10.0 in. (25.4 cm)
Diameter	3.5 in. (8.9 cm)	5.5 in. (14.0 cm)	8.5 in. (21.6 cm)	8.5 in. (21.6 cm)
Weight	0.2 lb (0.09 kg)	0.3 lb (0.14 kg)	0.6 lb (0.27 kg)	1.0 lb (0.45 kg)

Caution for Users: Petroleum products flowing over a plastic surface generate static electricity. Caution should be taken to ensure that the RFF is grounded to reduce static electricity buildup and reduce the chance of explosions or fire. Electrically bond the funnel by using a wire with a metal clip on each end and clamp one to the upper rim of the funnel and the other to the fueling source. For example, the metal gas can or nozzle from the pump.



Gasoline Filtration

The Most Complete Protection on the Water

Being on the water is fun, having water in your fuel is not. And more than ever today's high-performance gasoline inboard and outboard engines require clean, dry fuel. Racor filters offer the improved features and peace-of-mind that come with our quality fuel filter/water separators.

- Clear contaminant collection bowl with drain valve for outboards only
- 10 micron Aquabloc® Synergy media is standard
- High capacity and long life
- Rated 98% efficient at 10 micron per SAE test procedures
- Corrosion-resistant construction.
- Metal bowl units for inboard powered boats meet 33 CFR and USCG regulations
- Meets ABYC standard for gasoline-powered vessels

Every Time You Squeeze The Trigger, You Threaten Your Engine's Life.

No matter how carefully gasoline is handled or stored, dirt, rust, gums, algae, and water are going to find their way in, and just a few drops can leave you dead in the water. Racor gasoline fuel filter/water separators with Aquabloc® Synergy media remove virtually 100% of damaging water and solids, allowing engines to run with more power and greater efficiency. Install a Racor mounting head or spin directly onto your existing filter head to protect your engine and improve its performance. Spin on a Racor fuel filter/water separator, for the life of your engine.

Integral primer pump versus the old primer bulb for outboards



Racor innovation leads the market again. The new 490R-RAC-01 gasoline fuel filter/water separator with integral primer pump (for outboards only) eliminates the need to install a primer bulb in the fuel line.



Specifications	120R-RAC-01	120R-RAC-02	320R-RAC-01	320R-RAC-02	490R-RAC-01	660R-RAC-01	660R-RAC-02	3120R-RAC-32
Max. Flow Rate	30 GPH (114 LPH)	30 GPH (114 LPH)	60 GPH (227 LPH)	60 GPH (227 LPH)	90 GPH (341 LPH)	90 GPH (341 LPH)	90 GPH (341 LPH)	120 GPH (454 LPH)
Filter (10 micron) (2 micron)	S3240	S3240TUL	S3227	S3228TUL	S3227	S3232	S3232TUL	S3232TUL
	N/A	N/A	S3228SUL	S3228SUL	S3228SUL	N/A	N/A	N/A
Center Threads	M18 x 1.5	M18 x 1.5	1"-14	1"-14	1"-14	1"-14	1"-14	1"-14
Port Size	1/4"-18 NPTF 2 - Inlet 2 - Outlet	1/4"-18 NPTF 2 - Inlet 2 - Outlet	1/4"-18 NPTF 2 - Inlet 1 - Outlet	1/4"-18 NPTF 2 - Inlet 1 - Outlet	3/8"-18 NPTF 2 - Inlet 2 - Outlet	3/8"-18 NPTF 2 - Inlet 2 - Outlet	3/8"-18 NPTF 2 - Inlet 2 - Outlet	1/2"-14 NPTF 1 - Inlet 1 - Outlet
Height	6.5 in. (16.5 cm)	6.0 in. (15.2 cm)	9.4 in. (23.9 cm)	9.0 in. (22.9 cm)	9.9 in. (25.1 cm)	11.0 in. (27.9 cm)	10.5 in. (26.7 cm)	10.4 in. (26.4 cm)
Width	3.2 in. (8.1 cm)	3.2 in. (8.1 cm)	4.0 in. (10.2 cm)	4.0 in. (10.2 cm)	4.5 in. (11.4 cm)	4.2 in. (10.7 cm)	4.2 in. (10.7 cm)	4.0 in. (10.2 cm)
Depth	3.2 in. (8.1 cm)	3.2 in. (8.1 cm)	4.0 in. (10.2 cm)	4.0 in. (10.2 cm)	4.8 in. (12.2 cm)	4.5 in. (11.4 cm)	4.5 in. (11.4 cm)	5.0 in. (12.7 cm)
Weight (approx.)	1.1 lbs (0.5 kg)	1.2 lbs (0.5 kg)	2.0 lbs (0.9 kg)	2.0 lbs (0.9 kg)	2.6 lbs (1.2 kg)	3.0 lbs (1.4 kg)	3.0 lbs (1.4 kg)	2.0 lbs (0.9 kg)
Clean Pressure Drop	0.2 PSI (0.01 bar)	0.2 PSI (0.01 bar)	0.6 PSI (0.04 bar)	0.6 PSI (0.04 bar)	1.0 PSI (0.07 bar)	0.6 PSI (0.04 bar)	0.6 PSI (0.04 bar)	0.2 PSI (0.01 bar)
Max. Working Pressure¹	7.0 PSI (0.5 bar)	7.0 PSI (0.5 bar)	7.0 PSI (0.5 bar)	7.0 PSI (0.5 bar)	7.0 PSI (0.5 bar)	7.0 PSI (0.5 bar)	7.0 PSI (0.5 bar)	7.0 PSI (0.5 bar)
Service Clearance (under bowl)	1.0 in. (2.5 cm)	1.0 in. (2.5 cm)	1.0 in. (2.5 cm)	1.0 in. (2.5 cm)	1.0 in. (2.5 cm)	1.0 in. (2.5 cm)	1.0 in. (2.5 cm)	1.0 in. (2.5 cm)
Ambient Temp Range	-40° to +255°F (-40° to +124°C)							
Max. Fuel Temperature	190°F (88°C)							

¹ Pressure installations are acceptable up to the maximum PSI shown. Racor filter/separators will not separate oil from gasoline in blended fuel mixtures.

Upgrade Your Gasoline Filter

Convenient Spin-ons

Now, owners of inboard or outboard engines can get smoother operation and longer life—all in one easy spin, onto

their existing engine filter heads. There's a choice of rugged, reusable clear bowls with self-venting drains (for outboard

applications), or a metal bowl with drain plug (for inboard applications). Metal bowls are UL Listed and USCG accepted.



PFF5510	Replaces Mercury, Mercruiser, Quicksilver, Yamaha, Suzuki, SMI, Volvo Penta, Sierra, AquaPower, Honda, Tohatsu and other filter heads. 10 micron. 11/16"-16 Center Thread	Inboard or Outboard
----------------	--	---------------------



B32020MAM	Replaces Mercury, Mercruiser, Quicksilver, Yamaha, Suzuki, SMI, Volvo Penta, Sierra, AquaPower, Honda, Tohatsu and other filter heads (comes with a metal bowl). 10 micron. 11/16"-16 Center Thread	Inboard or Outboard
------------------	--	---------------------



S3220TUL [†]	Replacement filter for B32020MAM. 10 micron. 11/16"-16 Center Thread	Inboard or Outboard
------------------------------	---	---------------------



B32021MAM	Replaces OMC. UL Recognized (comes with a metal bowl). 10 micron. 1"-12 Center Thread	Inboard or Outboard
------------------	--	---------------------



S3221TUL	Replacement filter for B32021MAM. 10 micron. 1"-12 Center Thread	Inboard or Outboard
-----------------	---	---------------------



B32013	Replaces Mercury, Mercruiser, Quicksilver, Yamaha, Suzuki, SMI, Volvo Penta, Sierra, AquaPower, Honda, Tohatsu and other filter heads (comes with clear bowl). 10 micron. 11/16"-16 Center Thread	Outboard
---------------	--	----------



S3213	Replacement filter for B32013. 10 micron. 11/16"-16 Center Thread	Outboard
--------------	--	----------



B32014	Replaces OMC (comes with a clear bowl). 10 micron. 1"-12 Center Thread	Outboard
---------------	---	----------



S3214	Replacement filter for B32014. 10 micron. 1"-12 Center Thread	Outboard
--------------	--	----------

[†] Optional 2 micron filter (S3220SUL).

Compact Gasoline Filters for Smaller Boats and Personal Watercraft



Specifications	025-RAC-01	025-RAC-02	110A
Max. Flow Rate	25 GPH (95 LPH)	25 GPH (95 LPH)	35 GPH (132 LPH)
Media	250 micron (cleanable plastic screen)	10 micron (Aquabloc [®] filter)	10 micron (Aquabloc [®] filter)
Port Size	1/4"-18 NPTF	1/4"-18 NPTF	1/4"-18 NPTF 2 - Inlet 2 - Outlet
Dimensions	H 4.3" x D 2.1"	H 4.3" x D 2.1"	H 6" x D 3.3" x W 3.2"

800 Series Fuel Filtration



Specs	804MA30	75804MA30	79804MA10 /30
Flow Rate	240 GPH (908 LPH)	480 GPH (1817 LPH)	720 GPH (2725 LPH)
In/Out Ports	3/4" NPT	3/4" NPT	3/4" NPT
Height	20.6 in. (52.3 cm)	20.6 in. (52.3 cm)	20.6 in. (52.3 cm)
Width	6.7 in. (17.0 cm)	19.0 in. (48.3 cm)	27.0 in. (68.6 cm)
Depth	8.9 in. (22.6 cm)	17.8 in. (45.2 cm)	17.8 in. (45.2 cm)
Delta P	0.48 PSI (0.03 bar)		
Max Working Pressure	15 PSI (1.03 bar)		
Water Capacity	40.6 oz (1.2 L)		
Weight	25 lbs (11.3 kg)	60 lbs (27.2 kg)	90 lbs (40.8 kg)

Racor's compact 804MA Series diesel fuel filter/water separator, made of 100% steel construction to meet ABS and USCG requirements for marine fuel filters on classed and inspected vessels. The 804MA series are available in single, dual valved and triple valved configurations and handle fuel flow rates of 240, 480 and 720 gallons per hour, respectively; utilizing the standard Racor 2020 Series filter cartridges.

- **100% Steel Construction** By ASME Certified Welders
- Stainless Steel T-handle On Steel Lid
- Steel/High Pressure Glass Water Sight-Gauge
- Steel Contaminant Sump With Steel Drain Plug
- Marine-Grade White Exterior Coating
- Durable Steel Mounting Brackets

800 Series fuel filter/water separators offer large diesel engine operators ease of maintenance and continuous engine operation.

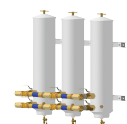

Specifications	75806MA	812MA	75812MA	79812MA
Maximum Flow Rate	720 GPH (2725 LPH)	720 GPH (2725 LPH)	1440 GPH (5451 LPH)	2160 GPH (8176 LPH)
Fuel Ports	1" NPT	1" NPT	1" NPT	1 1/4" NPT
Max Working Pressure	30 PSI (2.1 bar)	30 PSI (2.1 bar)	30 PSI (2.1 bar)	30 PSI (2.1 bar)
Clean Pressure Drop	3.2 PSI (0.2 bar)	3.2 PSI (0.2 bar)	6.0 PSI (0.4 bar)	5.2 PSI (0.35 bar)
Replacement Filter	(2) RK 22788*	RK 22610**	(2) RK 22610**	(3) RK 22610**
Height	22.8 in. (57.9 cm)	33.2 in. (84.3 cm)	33.2 in. (84.3 cm)	33.2 in. (84.3 cm)
Width	21.8 in. (55.4 cm)	6.6 in. (16.8 cm)	21.8 in. (55.4 cm)	33.3 in. (84.6 cm)
Depth	16.0 in. (40.6 cm)	8.9 in. (22.6 cm)	16.0 in. (40.6 cm)	16.0 in. (40.6 cm)
Weight (approx.)	52 lbs (23.6 kg)	36 lbs (16.3 kg)	89 lbs (40.4 kg)	133 lbs (60.3 kg)
Sump Capacity	2 gal (7.6 l)	1 gal (3.8 l)	2 gal (7.6 l)	2.9 gal (11.0 l)
Service Clearance (above)	12.0 in. (30.5 cm)	12.0 in. (30.5 cm)	12.0 in. (30.5 cm)	12.0 in. (30.5 cm)
(below)	4.0 in. (10.2 cm)	4.0 in. (10.2 cm)	4.0 in. (10.2 cm)	4.0 in. (10.2 cm)
Ambient Temp Range	-40° to +255°F (-40° to +124°C)			
Max Fuel Temperature	190°F (88°C)			

* RK 22788 – Replacement filter kit (contains one each of 4021 and 4022 filter and a lid gasket; 75806MA requires 2 kits; 79806MA requires 3 kits).

** RK 22610 – Replacement filter kit (contains one each of 8021 and 8022 filter and a lid gasket; 75812MA requires 2 kits; 79812MA requires 3 kits).

Fuel Transfer & Polishing Cart

FBO-10 and FBO-14

Racor's FBO-10 and FBO-14 filter assemblies are designed to meet tough hydrocarbon refueling conditions and provide for ease of filter change-outs. The FBO assemblies can handle flow rates from 20 to 55 GPM (75 to 208 LPM) depending on filter specified and fuel being filtered.

The slotted locking ring collar attaches the filter housing to the aluminum die cast filter head with four bolts. Metal hand knobs are provided for ease of maintenance.

Powder coated components capable of 150 PSI @ 240°F max design pressure.

Steel filter bowl assembly, a manual vent valve, and a manual drain valve help provide ease of service—especially significant given the FBO assembly's wide range of installations, including aviation fuel trucks, aviation fueling cabinets, diesel fuel dispensing systems, marine fuel docks, and fuel systems on large diesel engines. 1 1/2" NPT inlet and outlet.



Mounting bracket included.

Specifications	FBO-10-MA	FBO-14-MA
Fuel Ports	1 1/2" NPT	1 1/2" NPT
Max. Flow Rate	20 to 55 GPM (75 to 208 LPM) depending on filter specified and fuel filtered	
Max. Working pressure	150 PSI @ 240°F (10.3 bar @ 115°C)	
Clean Pressure Drop	1 PSI (0.07 bar)	1 PSI (0.07 bar)
Height	18.8 in. (47.8 cm)	22.6 in. (57.4 cm)
Width	8.6 in. (21.8 cm)	8.6 in. (21.8 cm)
Depth	8.6 in. (21.8 cm)	8.6 in. (21.8 cm)
Weight (approx.)	13 lbs (5.9 kg)	16 lbs (7.3 kg)
Service Clearance	12.0 in. (30.5 cm)	16.0 in. (40.6 cm)
Ambient Temp Range	-40° to +255°F (-40° to +124°C)	
Max Fuel Temperature	190°F (88°C)	

FBO Replacement Filter Options

Water Separator

Water separator filters remove water and contaminants from hydrocarbon fuel streams and are the most popular filters.

Silicone Treated

Silicone treated fuel filters remove particle contaminants down to one micron. Silicone filters can also be used upstream, before a fuel filter/water separator, to extend filter life.

Water Absorber

Water absorber filters absorb water and filter out contaminants from diesel fuel and other hydrocarbon streams.

FLOW RATE	DIESEL	20 GPM (75.7 LPM)	25 GPM (94.6 LPM)	20 GPM (75.7 LPM)
	KEROSENE	21 GPM (75.7 LPM)	35 GPM (132.5 LPM)	35 GPM (132.5 LPM)
FBO	Micron Rating	Water Separator	Silicone Treated (pre-filter)	Water Absorber
FBO-10 (6 X 10 Filter)	1	FBO 60327	FBO 60330	FBO 60333
	5	FBO 60328	FBO 60331	FBO 60334
	10	FBO 60353 FBO 60362 (Synergy) - NEW*	FBO 60354	FBO 60355
	25	FBO 60329	FBO 60332	FBO 60335
FLOW RATE	DIESEL	25 GPM (94.6 LPM)	30 GPM (113.6 LPM)	25 GPM (94.6 LPM)
	KEROSENE	30 GPM (113.6 LPM)	50 GPM (189.3 LPM)	55 GPM (208.2 LPM)
FBO-14 (6 X 14 Filter)	1	FBO 60336	FBO 60339	FBO 60342
	5	FBO 60337	FBO 60340	FBO 60343
	10	FBO 60356	FBO 60357	FBO 60358
	25	FBO 60338	FBO 60341	FBO 60344

*Additional product details located in cut sheet RSL0287.

FC-16-25

The Portable Fuel Filtration System is a practical and economical maintenance tool that contributes to optimum engine performance, regardless of application.

- Up to 16 GPM flow rate
- 2 Wheel cart with large wheels for easy movement over obstacles
- Tool less filter change out
- Filter shows differential pressure for filter element change out
- Sight glass and drain valve to detect and remove water
- Bypass valve for fluid transfer only
- Includes hose and wands

Specifications	FC-16-25
Application	power generation, fuel transfer, and fuel storage
Replacement Filter*	FBO 60338
Flow Rate	Up to 16 GPM
Maximum Pressure Rating	150 PSI (10 bar)
Height	40.7 in. (103.8 cm)
Width	25.5 in. (64.8 cm)
Length	19.8 in. (50.3 cm)
Weight (dry)	107 lbs (48.5 kg)
Max. Fuel Operating Temperature	100° F (38° C)
Power Requirements	110V

*For additional replacement element options see chart on pg 16.



- Suitable for use with diesel fuels.
- Fluoroelastomer seals for biodiesel compatibility.
- Head material is cast-iron, and bowl material is steel.

DFBO-10-MA and DFBO-14-MA

The DFBO duplex filter brings Racor FBO filters to the engine room or any other high flow environment. The duplex design ensures that fuel is efficiently filtered without interruption. The cast-iron head and steel bowls mean that it can be used in Marine applications, that require ABS certification.

The DFBO comes with two 25 micron elements allowing diesel flows up to 34 GPM (130 LPM) if open to full flow. A prefilter, a water separator/particle filter, or a water absorptive filter can be used.

Specifications	DFBO-10-MA	DFBO-14-MA
Fuel Ports	1.0" NPT Female (Inlet and Outlet)	1.0" NPT Female (Inlet and Outlet)
Max. Flow Rate	20 to 34.3 GPM (75 to 128 LPM) depending on filter specified and fuel filtered	
Max. Working pressure	100 psi @ 140°F (7.0 bar @ 60°C)	
Clean Pressure Drop	1 PSI (0.07 bar)	1 PSI (0.07 bar)
Height	22.66" (57.56 cm)	26.8" (68.07 cm)
Width	21.62" (54.9 cm)	21.62" (54.9 cm)
Depth	8.81" (22.38 cm)	8.81" (22.38 cm)
Weight (approx.)	80 lbs (36.3 kg)	85 lbs (38.6 kg)
Service Clearance	1.13" (2.87 cm)	1.13" (2.87 cm)
Ambient Temp Range	-40° to +255°F (-40° to +124°C)	
Max Fuel Temperature	190°F (88°C)	

Crankcase Filtration

In a robust, compact package, the patented Racor Closed Crankcase Ventilation (CCV) Filter Systems provide superior oil coalescence and crankcase pressure control under the most severe conditions.

CCV systems eliminate crankcase emissions and provide a cleaner engine room environment by performing the following functions:

- They reduce oil consumption by separating the oil from crankcase gases and returning the oil to the sump.
- The high-efficiency filter prevents fouling of the turbocharger and after-cooler.
- Keeps engine room and components clean.
- Filtered crankcase gas is returned to the engine intake system for re-combustion instead of polluting the environment.

The only routine maintenance required for the Racor Closed Crankcase Ventilation filter system is filter replacement. Typical service life of the high-performance filter in diesel applications is 750 hours. Some variations in service life occur depending on load profile, engine wear condition, flow, aerosol mass concentration of crankcase emissions, and soot concentration.

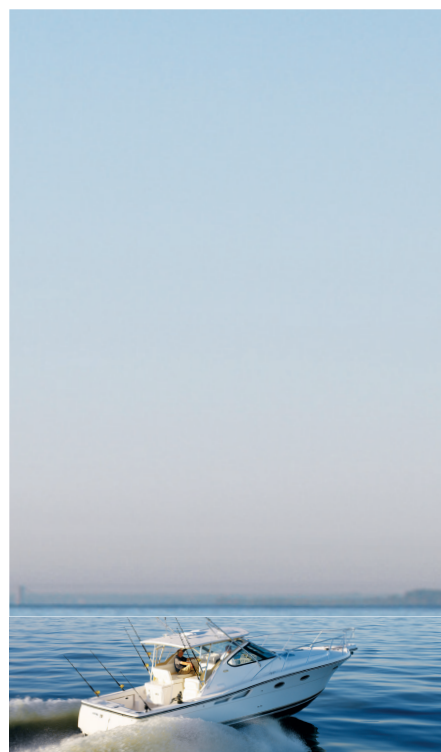

Specifications	CCV45 Series	CCV60 Series	CCV80 Series	CCV120 Series
Bypass Assembly Series	CCV4500	CCV6000	CCV8000	CCV12000
Non-Bypass Assembly Series	CCV4501	CCV6001	CCV8001	CCV12001
Maximum Flow Rate	10 CFM (283 LM)	20 CFM (566 LM)	40 CFM (1133 LM)	50 CFM (1416 LM)
Maximum Engine Rating	400 HP (298.3 KW)	800 HP (596.6 KW)	1600 HP (1193.1 KW)	2000 HP (1491.4 KW)
Inlet/Outlet Port Size	1 3/16" -12 STOR	1 5/8" -12 STOR	1 7/8" -12 STOR	1 7/8" -12 STOR
Weight (approx.)	3.3 lbs (1.5 kg)	5.0 lbs (2.3 kg)	8.7 lbs (3.9 kg)	9.3 lbs (4.2 kg)
Replacement Filter Media Density: Low	CCV55248-04	N/A	N/A	N/A
Replacement Filter Media Density: High	CCV55248-08	CCV55274-08	CCV55222-08	CCV55222-12-08
Replacement Filter Media Density: Ultra	CCV55248-10	CCV55274-10	CCV55222-10	CCV55222-12-10
Housing Material	Die cast head, glass-filled nylon and black powder epoxy-coated steel bowl.	Die cast head, glass-filled nylon and black powder epoxy-coated steel bowl.	Die cast head, glass-filled nylon and black powder epoxy-coated steel bowl.	Die cast head, glass-filled nylon and black powder epoxy-coated steel bowl.
Engine Block Check Valve Return Fitting	1/4" NPT	1/4" NPT	3/8" NPT	3/8" NPT
Swivel Fitting (Qty.)	#6 JIC (2 pcs.)	#6 JIC (2 pcs.)	#8 JIC (2 pcs.)	#8 JIC (2 pcs.)
Oil Drain Hose I.D.	0.375 in. (0.95 cm)	0.375 in. (0.95 cm)	0.5 in. (1.27 cm)	0.5 in. (1.27 cm)

Units can be manifolded to handle higher flow rates. Larger assemblies can be specified when extra-life is desired.

For complete product information, please see brochure 7790.

Reduce Emissions

Clean Up Engine Rooms and Engines

Marine diesel engines can benefit from the installation of a combination Racor Closed Crankcase Ventilation (CCV) and Air Filter/Silencer System. The CCV contains Racor's high-performance Vaporbloc™ filter made of depth-loading, micro-glass fiber coalescing media. The marine Air Filter/Silencer (AF) contains a washable media and is ruggedly built to provide an extended service life.

How the Systems Work

The engine crankcase breather is connected to the inlet of the Racor CCV assembly. The CCV outlet is connected to the engine's combustion air inlet via an air intake connector where filtered blowby gas is recycled through the combustion process. Oil collected in the CCV sump is returned to the crankcase through a hose and a drain check valve.

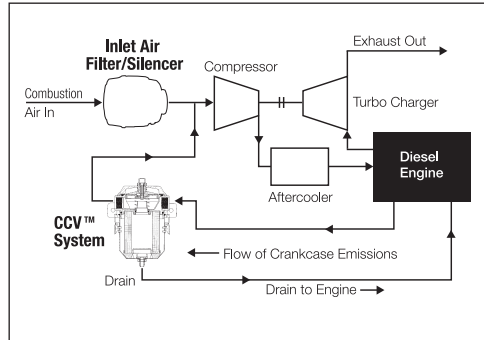

Air Filter/Silencers

The Racor Marine Air Filter removes contaminants introduced into the air from both outside and inside the vessel. Sand, salt, carpet fibers, and other contaminants are trapped in the oil-impregnated Vaporbloc™ filter media. The unique silencer housing design reduces turbo noise. An integral hose connection on the housing routes the clean blowby from the CCV back into the engine.

- A pop-up style indicator on the CCV assembly, alerts the operator of a bypass condition and the need for a CCV Vaporbloc™ filter change.
- Air Filter/Silencer comes standard with an integral vent port for CCV connection.
- Air filter media is washable; a cleaning kit is available.
- Optional tap sleeves for easy connection of existing air cleaner to CCV assembly.
- Prevents turbo and intercooler fouling.

Marine Engine Application Worksheet

In order to determine the correct Racor CCV system for a particular application, certain engine information is required. A complete kit is composed of the following:

1. Racor CCV assembly
2. Fitting/Hose Kit
3. Air Intake Connector (Tap Sleeve or Marine Air Filter/Silencer Assembly)

1 Select the Racor CCV Assembly:

Racor CCV application is determined by crankcase flow in cubic feet per minute or CFM. Flow on new engines is low but as the engine wears on, the CFM increases. Select the correct Racor CCV model by dividing the engine horsepower output by 40.

Example: CAT 3116/260HP ÷ 40 = 6.5 CFM, select CCV4500
 CAT 3406/525HP ÷ 40 = 13.13 CFM, select CCV6000

Maximum Flow Rate	
CCV Model	Flow
CCV4500	10 CFM (283 l/m)
CCV6000	20 CFM (566 l/m)
CCV8000	40 CFM (1133 l/m)
CCV12000	50 CFM (1416 l/m)



CCV units are designed to handle crankcase flow rates of up to 50 CFM (1416 l/m). Traditionally, the crankcase flow rate can be calculated as follows: Rated horsepower ÷ 40 = cubic feet per minute (CFM). This formula can only be used as a guide since recent improvements in piston design have produced engines with higher horsepower and lower blowby flow rates. The blowby flow rate of a worn engine, at time of overhaul, is generally double the flow rate when the engine is new. The flow rate of a worn engine is factored into the formula. **Note:** Specify left or right-hand inlet when ordering.



Cummins QSM11 marine engine with CCV cutaway

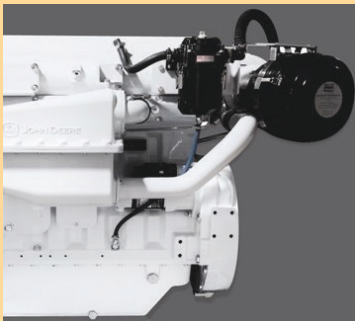

John Deere Marine PowerTech engine with Racor CCV/AF System



Marine Air Filter/Silencer (AF) System

2 Select a Fitting/Hose Kit:

Fitting/Hose Kits come with both fittings and enough hose for the inlet and outlet sides of the Racor CCV assembly. Racor CCV filter units require straight thread o-ring hose barb fittings available only from Racor distributors. In order to determine the correct application, you will need to know the quantity and the outside diameter of engine breather(s)/hose connection. Fitting/Hose Kits are available in various sizes and hose configurations.

3 Air Intake Connector — Select A, B, or C, Depending on Application:

A. Tap Sleeve

Tap sleeves connect the Racor CCV outlet to the engine's air intake. Determine the inside diameter of the hose between the turbo and the air cleaner. This will determine the outside diameter of the tap sleeve required for completion of the installation of your Racor CCV system. Verify all dimensions required of the tap sleeve before ordering.

Example: John Deere #4045T — Hose between turbo and air cleaner is 4" inside diameter. Correct tap sleeve is CCV40100, which is 4" outside diameter with a 1" OD hose barb.

Tap Sleeves



Tap Sleeve	Dimensions		
	O. D.	Length	Hose Barb
CCV30100	3 in.	5 in.	1 in.
CCV40100	4 in.	5 in.	1 in.
CCV50125	5 in.	6 in.	1.1/4 in.
CCV60125*	6 in.	6 in.	1.1/4 in.

*Note: CCV60125 includes a 1 1/4" x 1 1/2" bushing (connects to 1 1/2" ID hose).

Part Number	Hose
CCV55540	3/4 in.
CCV55113	1 in.
CCV55114	1 1/4 in.
CCV55115	1 1/2 in.

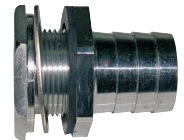

B. Hump Hose Fittings:

Use these with existing air cleaner-to-turbo rubber adapters.

C. Marine Air Filter Silencer Assembly.

In order to determine the correct marine air filter application, you will need to know the engine's marine air filter rating (AFR) and provide the hose connection to turbo. Choose the correct marine air filter application per the following guideline. Verify that the marine air filter dimensions will fit into your engine room.

4-cycle engines: $AFR = HP \times 2.0$

2-cycle engines: $AFR = HP \times 2.5$

Maximum Flow Rate	
Marine Air Filter	Air Flow Rate
AF M408512	800 CFM (377 l/s)
AF M501012	1200 CFM (566 l/s)
AF M601212	1600 CFM (755 l/s)
AF M701212	2000 CFM (944 l/s)

Note: If AFR is close to maximum capacity of the marine air filter as listed above, use the next size larger.

Example: DDC 12V92TA DDEC (2-cycle - twin turbo):

$826 \text{ hp} \times 2.5 = 1032.5 \text{ AFR per turbo} = (2) \text{ AF M501012}$

$1110 \text{ hp} \times 2.5 = 1387.5 \text{ AFR per turbo} = (2) \text{ AF M601212}$

CAT 3196 (4-cycle - twin turbo):

$660 \text{ hp} \times 2.0 = 1320.0 \text{ AFR} = (1) \text{ AF M601212}$

Marine Air Filters (AF) typically correspond with the following CCV models, see chart.

Marine Air Filter	CCV Model
AF M408512	CCV4500
AF M501012	CCV4500 or CCV6000
AF M601212	CCV8000
AF M701212	CCV12000

Air Filter/Silencer

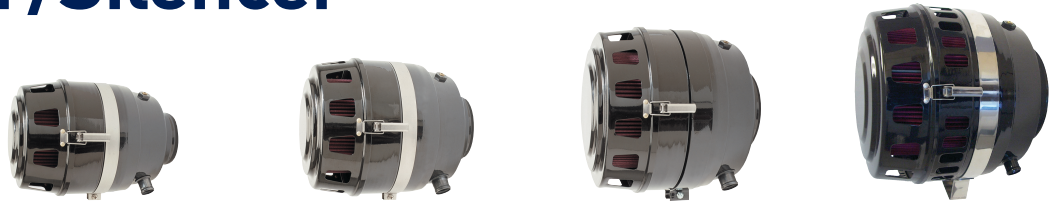

Specifications	AF M408512	AF M501012	AF M601212	AF M701212**
Max. Air Flow*	800 CFM (378 l/s)	1200 CFM (566 l/s)	1600 CFM (755 l/s)	2000 CFM (944 l/s)
Outlet Diameter	4.0 in. (10.2 cm)	5.0 in. (12.7 cm)	6.0 in. (15.2 cm)	7.0 in. (17.8 cm)
Filter	AF M8040	AF M8050	AF M8060	AF M8070
Length	12.5 in. (31.8 cm)	12.5 in. (31.8 cm)	12.5 in. (31.8 cm)	12.5 in. (31.8 cm)
Depth	9.6 in. (24.4 cm)	11.5 in. (29.2 cm)	13.5 in. (34.3 cm)	13.5 in. (34.3 cm)
Hose Barb Size	1.0 in. (2.5 cm)	1.25 in. (3.2 cm)	1.25 in. (3.2 cm)	1.0 in. (2.5 cm)
Weight	4.2 lbs (1.9 kg)	5.0 lbs (2.3 kg)	8.0 lbs (3.6 kgs)	8.0 lbs (3.6 kgs)
Operating Temperature	-40° to +240°F (-40° to +116°C)			

*Values given are cubic feet per minute (CFM) and liters per second (l/s). **AF M701212-01 is available with a 1.25 in. hose barb.



Racor Part Number	Competitor Part Number	Dimensions D x H x D
AF M8145	CD170	10 x 8 x 10
AF M8121	CD174	7.5 x 6 x 7.5
AF M8122	CD175	7.5 x 7 x 7.5
AF M8126	CD178	7.5 x 10 x 7.5
AF M8010	CD180	3" Air Separator
AF M8153		12 x 12 x 12
AF M8037	CD184	9 x 14 x 6.875
AF M8047	CD185	10 x 14 x 7
AF M8152		12 x 7 x 12
AF M8157		12 x 14 x 12
AF M8026	CD190	7.5 x 10 x 5.125
AF M8025	CD125	7.5 x 8 x 5.125
AF M8034	CD196	9 x 9 x 7
AF M8033	CD197	9 x 12 x 6.88
AF M8134	CD200	9 x 9 x 9
AF M8133	CD201	9 x 12 x 9
AF M8141	CD202	9 x 12 x 9

Air Filter Replacements

Racor offers direct replacements for the intake air filter portion of competitive air filters/silencers. Also available is the replacement filter for the vacuum limiter air separator.

The filter media for all replacement filters is an oil-impregnated cotton gauze and is sandwiched between pleated, epoxy-coated aluminum wire-mesh with polyurethane sealing surfaces. This product is cleanable and must be oiled before re-using.

Washing and Re-oiling Kit



AF M82006



How They Work

LG50 (for gasoline)



Stage 1:

Venting tank fuel is diffused by the flow diverter and air is allowed to bypass the diverter. Fuel is directed back into the fuel tank.

Stage 2:

Vapor collects on the interior surfaces and coalesces. The fuel returns downward by gravity and air continues up and out of the unit.



LG100 (for diesel/gasoline)

Stage 1:

Venting tank fuel is diffused by the flow diverter and air is allowed to bypass the diverter. Fuel is directed back into the fuel tank.

Stage 2:

Fuel de-foams through a fine wire mesh screen which filters out large contaminants. Under the screen, the fuel collects temporarily until it can freely flow back to the fuel tank.

Stage 3:

Vapor collects on the interior surfaces and coalesces. The fuel returns downward by gravity and air continues up and out of the unit.

Note: The safety relief valve includes a floating check ball which will not permit a large in-rush of fuel to bypass. In the event of internal pressure reaching 2.4 PSI (0.17 bar), the spring will compress and open the safety seat.

Eliminate Fuel Vent Line Overflow During Refueling

ECO Friendly



Next time you fill up, watch your fuel vent line. A typical refueling will send up to half a gallon or more of fuel spilling overboard. Fuel spillage is not only expensive, it's absolutely deadly to fragile lakes, rivers, and waterways. Also, USCG and other regulations prohibit the discharge of oils with civil and criminal penalties.

Installed in the fuel tank vent line, the Racor Fuel/Air Separator efficiently separates air from fuel forced into the line. Air is vented, and all fuel is returned to the tank. The Fuel/Air Separator captures fuel normally discharged due to agitation and thermal expansion up to 2.4 PSI (0.17 bar). It also eliminates damage to expensive stripping, labels, and protects finishes from fuel stains. The unit is also maintenance free—there's nothing to rust or corrode.

The Racor Fuel/Air Separator fits neatly into your vent line, actually replacing a section of the line and fittings are included with each kit. One Fuel/Air Separator unit is required for each vent line. Fuel/Air Separators fit 5/8" vent lines, 1/2" fittings are available.



Specifications	LG50	LG100
Application:		
Gasoline	Yes	Yes
Diesel	No	Yes
Maximum Air Flow	12 CFM (340 l/m)	17 CFM (481 l/m)
Hose Barb ¹	5/8"	5/8"
Thermal Expansion	Up to 2.4 PSI (0.17 bar)	Up to 2.4 PSI (0.17 bar)
Height	6.0 in. (15.2 cm)	9.8 in. (24.9 cm)
Diameter	1.8 in. (4.6 cm)	4.0 in. (10.2 cm)
Weight (dry)	1.2 lbs (0.5 kg)	1.6 lbs (0.7 kg)

Notes: ¹ Order part **RK 50033** for 1/2" NPTF threaded fitting)

Marine Rated Hose

No-Skive Hose and Fittings

- No-Skive hose and fittings do not require removal of the outer hose cover, eliminating premature failure caused by skiving too long or short.
- Use of No-Skive hose and fittings keeps outer cover intact, protecting vulnerable wire wrap during fitting assembly.
- Packaged in 350-foot reels or 50-foot kits.
- Cushioned grip increases hose life – supporting cushion of compressed rubber between gripping threads on fitting reduces wire movement, minimizing stress.
- High-tensile steel wire braid.
- Corrosion Protection – steel wire braid of No-Skive hose is never exposed because outer rubber cover is not removed before assembling fitting.
- No-Skive fittings allow socket threads to penetrate outer hose cover, and grip the wire braid of the hose.
- Simple two step assembly—attach socket to hose, thread nipple to socket.
- Passed 2 1/2 minute fire test.
- 500 PSI working pressure.

Parker Marine Hose is a USCG-rated hose for gasoline, diesel, lube oil, and hydraulic systems for commercial and recreational applications.

It delivers test-proven performance in a wide operating temperature range and constant working pressure. It is of a long-lasting reinforced construction, kink and cut resistant, and compatible with a variety of standard 100R5 fittings.



Fire-Resistant Marine Hose Meets SAE J1527, Type A, Class 1, and SAE J1942 Standards



Part Number	Hose I.D.		Hose O.D.		Working Pressure		Burst Pressure		Min. Bend Radius		Weight (per foot)		Inches of Mercury	
	in.	cm	in.	cm	PSI	mPa	PSI	mPa	in.	cm	lbs/ft	kg/m	Hg	kPa
CGH-5	1/4	0.6	0.6	1.5	500	3.4	2000	13.8	1	2.5	0.19	0.09	20	68
CGH-6	5/16	.8	0.7	1.8	500	3.4	2000	13.8	1 1/4	3.2	0.23	0.10	20	68
CGH-8	13/32	1.0	0.8	2.0	500	3.4	2000	13.8	1 3/4	4.5	0.28	0.13	20	68
CGH-10	1/2	1.3	0.9	2.3	500	3.4	2000	13.8	2 1/4	5.7	0.39	0.18	20	68
CGH-12	5/8	1.6	1.1	2.8	500	3.4	2000	13.8	2 3/4	7.0	0.47	0.21	20	68
CGH-16	7/8	2.3	1.2	3.0	500	3.4	2000	13.8	3 1/2	8.9	0.41	0.19	20	68



RK23191

Stainless Steel WIF Probe

- ABS Marine Type Approved, Cert. #11-HS800012-PDA.
- UL Marine Listed, 168Y.
- Meets requirements of ISO19921 fire resistance test.
- Robust 303 stainless steel and ceramic design.
- One inch (1") hex drive body, over 3 in. (7.6 cm) long.
- 1/2"-20 straight threads with SAEJ1926 sealing design.
- FKM o-ring material for durable service life.
- Detachable Packard GT-Series connector and 36" long wiring loom.

Water Detection Probes

Stainless Steel Water In Fuel (WIF) Probe

The new all-steel and ceramic water in fuel (WIF) probe was designed to meet new IMO Marine Requirements. Racor's new RK23191 water probe can be used with all of our American Bureau of Shipping (ABS) and Underwriters Laboratories, Inc. (UL) Marine products. This passive probe design has a 303 stainless steel housing which captivates a ceramic insulator and stainless probe tip. The housing features a durable plastic connector housing to attach to an external pigtail harness with yellow and black 18 AWG wires (no polarity).

Water Probes

Racor offers a wide selection of water-in-fuel (WIF) detection systems, each designed for specific filter assemblies and installation requirements.

Water probes simply provide metal pin tip entry into a water collection bowl. Some contain no active electronics and require an external electronic detection module to detect water.

Electronic Detection Modules

Detection modules have internal electronics that pass a small current across special metal pins. When water bridges the pin tips, a solid state switch is activated allowing a larger current to flow to drive a light or provide a signal to an engine computer. Electronic detection modules will automatically reset once water is drained away from the probe tips.

Detailed instructions are supplied with every WIF sensor and electronic detection module.

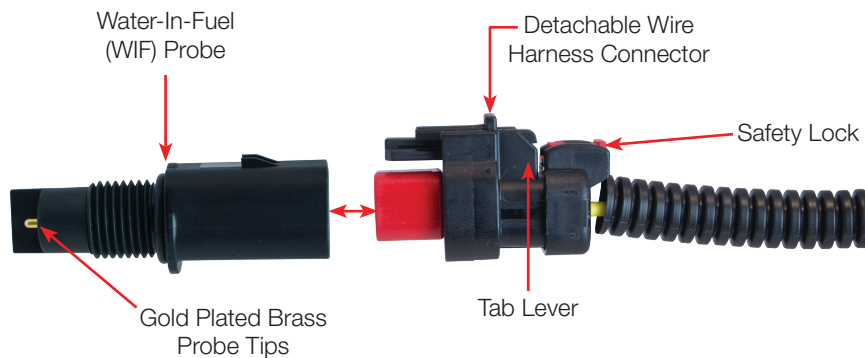

Specifications	RK 55484	RK56235	RK30880E**	RK 30964	RK 21069
Mating Connector	Delphi Packard 12162000	Delphi Packard 12162000	Racor 22556	None	None
Thread Size	1/2"-20 UNF				
Volts	12 or 24	12 or 24	12 or 24	12 or 24	12 or 24
Probe Tips	Gold Plated Brass	Gold Plated Brass	Beryllium Copper	Stainless Steel	Stainless Steel
Wire Length (L)	8.0 in. (20.3 cm)	4.0 in. (10.2 cm)	8.0 in. (20.3 cm)	8.0 in. (20.3 cm)	8.5 in. (21.6 cm)
Internal Resistor	220K ohm	220K ohm	Amplifier	None	None
Application	Cummins	-	All	All	All
Output	-	-	To Ground	-	-









** These WIF probes have a built-in water detection module.

Water Detection Modules & Kits

Racor Water Detection Kits are available in a wide selection for various installation requirements. Under-dash, in-dash, and remote mount, these solid-state units may be used with any Racor fuel filter/water separator and water probe. They are manufactured using the highest quality materials and

are all 100% electrically tested. An electronic detection module analyzes electrical resistance at the water probe and determines if water is present. If so, the detection module operates to indicate water, based on its features listed below. All units reset automatically after water is removed (unless specified).

Caution: The water probe and detection modules work with 12 or 24 volts, direct current only and should never be wired to other brand modules or household 110 or 220 volts, alternating current. Use the guide below to find the correct detection module for your application.

Part Number	Description	Voltage	Image
RK 12870	Under-dash water detection module. Light illuminates and alarm sounds when water is detected. Water must be drained to reset light and stop alarm. Plastic enclosure measures: 1.38" square x 1.25" deep. Water probe included.	12 vdc	
RK 20725	Under-dash mount water detection module. Light only. Green 'ON' lamp illuminates with power on. Red 'DRAIN' lamp illuminates when water is detected. Initial power-up self diagnosis feature and circuit protection included. Plastic enclosure measures: 2.75" x 1" x 1.5". Water probe included.	12 vdc	
RK 20725-24	Same as above	24 vdc	
RK 11-1570	2" gauge-type water detector and filter restriction module. Includes pre-set vacuum switch (7 inHg), connector, and outlet adapter fitting. Red 'DRAIN' or 'CHANGE FILTER' lamp illuminate and horn sounds when water is detected. Water probe included.	12 or 24 vdc	
RK 14329	Remote detection unit sends 12 VDC hot (+) signal when an input ground signal (from a water probe or a vacuum switch—not included) is received. Must be used with a relay to power a horn or indicator lamp (if draw is over 1 amp). Plastic enclosure measures: 3" x 2.5" x .75"	12 vdc	
RK 14321	Same as above	24 vdc	
14332	Under-dash mounts same as RK 14329 but sends a ground (-) signal. Enclosure size is same as RK 20725 above.	12 vdc	
RK 20163	Vacuum Switch Kit Non-adjustable, 'Normally Open' contacts close at 7 inHg (3.4 PSI) 1/8"-27 NPT threads. For use with all models.	N/A	
RK 21030	Vacuum Switch Connector Kit Molded connector with single 18 AWG., 18" blue wire lead.	N/A	
RK30880E	This kit includes new and enhanced detection electronics built into the probe body and works with 12 or 24 volt DC systems. Water probe and detection module all in one.	12 or 24 vdc	

Vacuum/Compound Gauge Kits





Vacuum and Compound (vacuum/pressure) gauges and related hardware are available to monitor filter condition. As the filter slowly becomes clogged with contaminants the restriction (resistance to flow) increases. The fuel pump still tries to draw fuel (suction) but because of this restriction less fuel is delivered to the engine and instead more air is pulled from it (fuel de-gassing). These results can cause the engine to lose power and eventually stall.

By installing a vacuum gauge in your fuel system (on the outlet side of the Racor filter) visual monitoring of filter condition is possible at a glance. Note the position of the dial, or apply the 'red line' decal provided with most kits. This will assist in easy monitoring as filter efficiency begins to decrease when a filter change is necessary.

Note: Intervals of filter changeout may vary depending on fuel cleanliness. Always keep a spare Racor filter on hand.

Accessories

Enhance Your Fuel Systems Performance and Ease of Service

Part No.	Description	Tread Size	
RK19492	UL-Listed Brass Drain Valve	1/4" NPTF	
RK19667	Compound Gauge, -30 inHg to 15 psi, Panel Mount, (2) Brass Fittings	1/4" NPT, Bottom Mount	
RK19668	Vacuum Gauge, -30 to 0 inHg, Remote Panel Mount, (2) Brass Fittings	1/4" NPT, Back Mount	
RK19669	Vacuum Gauge, -30 to 0 inHg	1/4" NPT, Bottom Mount	
RK19671	Vacuum Gauge, -30 to 0 inHg, Stainless Steel T-handle	1/4" NPT, Bottom Mount	

When is My Engine Air Filter "Used Up?"

Because it performs so well, it is not uncommon for the engine air filter to appear as if it has reached its capacity. The only way to know when the engine air filter has reached its capacity is to measure the restriction at service.

An effective way to verify restriction is with a filter restriction monitor. A restriction monitor will provide a quick and accurate assessment of the air filter's condition and remaining service life.



Standard Filter Monitor Part Numbers

Part Number	Range (in. water vac.)	Description
400033015 ^A	8-15 inHg (27-51 kPa)	Direct Mount
400033020 ^A	8-20 inHg (27-68 kPa)	Direct Mount
400033025 ^A	8-25 inHg (27-85 kPa)	Direct Mount
014440001 ^A	8-25 inHg (27-85 kPa)	Direct Mount w/ 90° Fitting

^A Unit standard with a 1/8"-27 NPT straight fitting.

Warning! Failure or improper selection or improper use of the products and/or systems described herein or related items can cause death, personal injury and property damage. This document and other information

from Parker Hannifin Corporation, its subsidiaries and authorized distributors provide product and/or system options for further investigation by users having technical expertise. It is important that you analyze all

aspects of your application and review the information concerning the product or system in the current product catalog. Due to the variety of operating conditions and applications for these products or systems, the user,

through its own analysis and testing, is solely responsible for making the final selection of the products and systems and assuring that all performance, safety and warning requirements of the applications are met.

The products described herein, including with limitation, product features, specifications, designs, availability and pricing, are subject to change by Parker Hannifin Corporation and its subsidiaries at any time without notice.



Parker's Product Information Center

Parker Hannifin has become a world leader in motion and control technology by providing premier customer service. That's what our Product Information Center is all about. Our experienced agents are ready to provide you with the product identification and referral service you need. Emergency breakdown calls are relayed via pager to agents on call who will respond promptly. Non-emergency calls are recorded and answered the next business day.

Tap Into the Knowledge Network

Every agent has access to extensive computer databases referenced by part number and product category.

Information encompassing 200 worldwide facilities, 400 product lines, and 1,200 market segments is at their fingertips. Our goal is to make it as easy as possible for you to do business with Parker.

Language Line Service

By using the Language Line Service, we can access interpreters for more than 140 languages immediately. Handling non-English-speaking inquiries is not a problem!

Product Information Center

U.S., Canada, Mexico call: 1-800-C-Parker (1-800-272-7537)
E-mail: c-parker@parker.com
Hours: Monday - Friday 8:00 a.m. to 6:30 p.m. EST
Saturday 7:00 a.m. to 12:00 p.m. EST

Quality Management System Certifications

•ISO 14001: 2004



Parker Filtration Group

Engine Mobile Original Equipment Division
Holly Springs, Mississippi
662 252 2656

Engine Mobile Aftermarket Division
Kearney, Nebraska
308 234 1951

Hydraulic & Fuel Filtration Division
Metamora, Ohio
419 644 4311

HVAC Filtration Division
Jeffersonville, Indiana
866 247 4827

Industrial Process Filtration Division
Mineral Wells, Texas
940 325 2575

Bioscience & Water Filtration Division
Bioscience Filtration
Oxnard, California
877 784 2234

Water Purification
Carson, California
310 608 5600

Gas Turbine Filtration Division
Alton, United Kingdom
+44 (0) 1420 541188

Aerospace Filtration Division
Greensboro, North Carolina
336 668 4444

Hydraulic & Industrial Filtration Division EMEA
Arnhem, Netherlands
+31 (0) 26 376 0376

Engine Mobile Filtration Division EMEA
Dewsbury, United Kingdom
+44 (0) 1924 487 037

Bioscience Engineering Filtration Division EMEA
Birtley, United Kingdom
+44 (0) 191 410 5121

Gas Separation & Filtration Division EMEA
Team Valley, United Kingdom
+44 (0) 191 402 9000

Latin America Filtration Division
Sao Paulo, Brazil
+55 12 4009 3500

China Filtration Division
Shanghai, China
+86 21 2067 2067

Korea Filtration Division
Hwaseon City, Korea
+82 31 359 0852

India Filtration Division
Chennai, India
+91 22 4391 0700

Australia Filtration Division
Castle Hill, Australia
+61 2 9634 7777

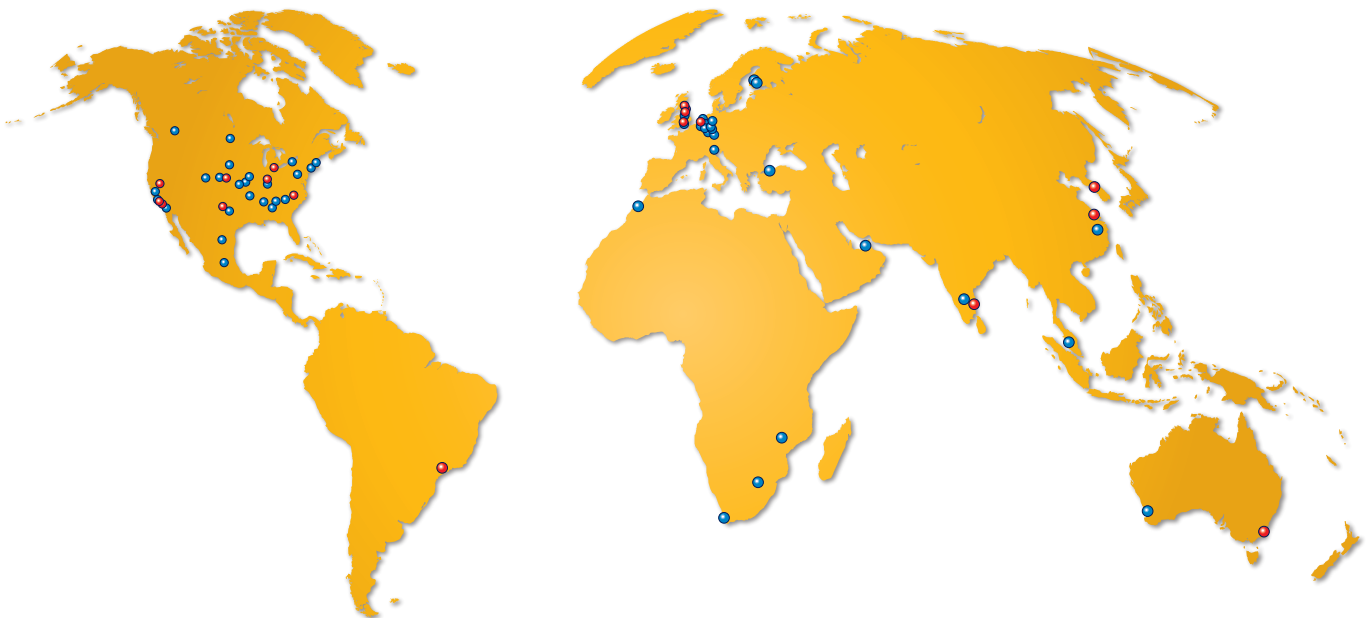

Parker Hannifin Corporation
Engine Mobile Original Equipment Division
1640 Cummins Drive
Modesto, CA 95358
phone 209 521 7860
www.parker.com/emoe