



Shown Installed on 1" TM PVC Flowmeter

---

## **QSI ELECTRONIC MODULE For FLOMEC® TM Meters**

---

This instruction covers the installation of the “no display” electronic module and the “display ready” electronic module with QSI1, QSI2, or QSI3 versions of communications electronics installed. The basic mechanical installation is the same for all electronic modules. The wiring connections and wiring diagrams differ depending on the electronic module being installed.

## MODULE CONTENTS

Check the contents of your module using the list below as reference.

- (1) Completely assembled QSI module
- (4) #4-20 x 7/8 in. Fillister Head Plastite® Screws.
- (1) Gasket
- (1) Plastic Spacer
- (1) Installation instructions
- (1) Set of (4) Strain reliefs

Additional items included with *Display Ready* module:

- (1) Display seal
- (4) #4-20 x 7/8 in. tapping screws
- (1) 10 pin male connector

## FLOMEC APP FOR ANDROID

To learn how to get started using the FLOMEC App, visit:  
[flomecmeters.com/downloads/flomec-app-quickstart.pdf](http://flomecmeters.com/downloads/flomec-app-quickstart.pdf)



[FLOMEC APP QUICKSTART](#)



## SPECIFICATIONS

MECHANICAL	
<b>Cover Plate Port Threads</b>	Female 1/2-20 UNF-2B (Compatible with PG7 thread)
<b>Port Strain Relief</b>	Hubble PG7
Grip Range	0.11"-0.26" (2.79 - 6.6mm)
<b>Port Conduit Adapter</b>	GPI PG7 x 1/2 in. NPT Male
Recommended Cable	Belden #9501 (2-Conductor w/Drain Wire, Shielded)
TEMPERATURES	
Operation Temperature	+32°F to +140°F (0°C to +60°C)
Ambient Air Operation Temp	0°F to +140°F (-18°C to +60°C)
POWER SUPPLY	
Voltage Requirement	Min. 12 VDC (voltages below 12V will result in meter accuracy issues)
	Max. 36 VDC (higher voltage may damage unit)
Battery Backup (QSI2, QSI3 Only)	Coin cell lithium, 3V (CR2032) UL APPROVED
MAX POWER CONSUMPTION	
TM Meter with QSI	170mA 4 watts @ 24VDC 6 watts @ 36VDC

ELECTRICAL	
Pollution Degree	2
Installation Category	1
Altitude	2000m Max.
Indoor use only	
OUTPUTS & COMMUNICATION	
QSI Version 1:	
Bluetooth	
Coil/Digital Pulse Input	
Pulse Output	
RS485	
Temperature Inputs	
BTU Calculator	
QSI Version 2:	
Bluetooth	
Coil/Digital Pulse Input	
Pulse Output	
Temperature Inputs	
BTU Calculator	
QSI Version 3:	
Bluetooth	
Coil/Digital Pulse Input	
Pulse Output	
4-20mA output	

**SPECIFICATIONS (continued)**

**DIMENSIONS**

Dimensions are shown in inches and [mm]

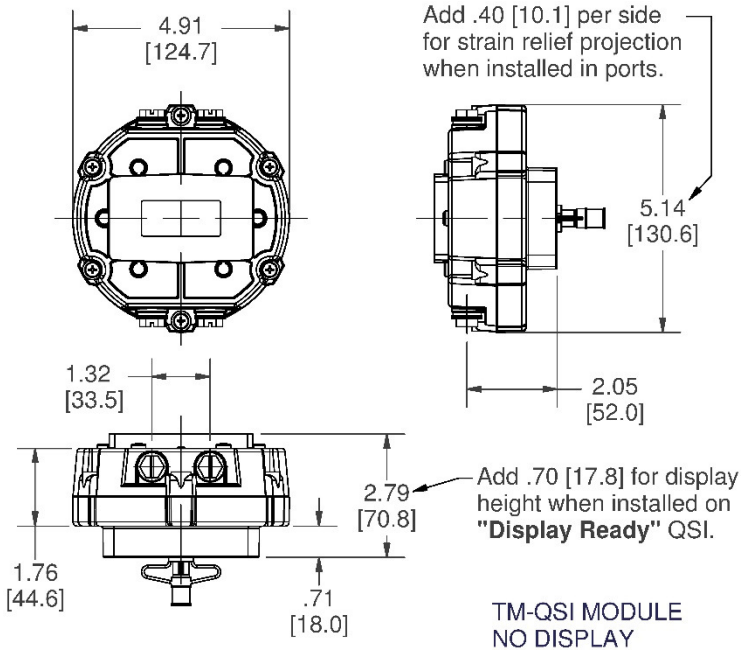

Figure 1

**APPROVALS & RATINGS**



The Waste Electrical and Electronic Equipment (WEEE) directive (2002/96/EC) was approved by the European Parliament and the Council of the European Union in 2003. This symbol indicates that this product contains electrical and electronic equipment that may include batteries, printed circuit boards, liquid crystal displays or other components that may be subject to local disposal regulations at your location. Please understand those regulations and dispose of this product in a responsible manner.

**RoHS Compliant (2011/65/EU)**

This product is in compliance with the RoHS Directive of the European Parliament and of the Council on the Restriction of the Use of Certain Hazardous Substances in Electrical and Electronic Equipment.

## INTRODUCTION

### QSI

The QSI communications module is a multiple capability electronics package and has three versions (QSI1, QSI2 or QSI3) available; each with its own mix of capabilities to better serve the customer (See Versions below).

- **QSI1:** Equipped with Bluetooth®, coil/digital pulse input, pulse output (flow or energy & scalable), RS485 (Modbus® RTU), temperature inputs, BTU calculator.
- **QSI2:** Equipped with Bluetooth, coil/digital pulse input, pulse output (flow or energy & scalable), temperature inputs, BTU calculator.
- **QSI3:** Equipped with Bluetooth, coil/digital pulse input, pulse output (flow scalable), 4-20mA output.

This manual contains information and meter wiring diagrams for the three different QSI electronics modules.

### IMPORTANT NOTICE

QSI module electronics are very sensitive to electric noise if operated within 6 inches of some electric motors, relays, transformers or other sources of electronic noise.

If the QSI electronics are used in a manner not specified by the manufacturer, the protection provided by the equipment may be impaired.

### GENERAL INFORMATION

QSI electronics are available factory installed on designated meters, or as modules that will adapt the electronics to other FLOMEC meters.

The QSI electronics converts the voltage (or pulses) from the meter into usable information to support the various capabilities of the modules. The modules also supply the display (when installed on display ready versions) with the information and power it needs to function as designed.

The QSI module electronics are powered by customer- supplied external power.

### SAFETY

**This product is not approved for use in hazardous locations.**

- Be sure O-rings and seals are kept in good repair.
- When applying power, adhere to specifications in this manual.
- Disconnect external power before attaching or detaching input or output wires.

**ASSEMBLY INSTRUCTIONS**

**NOTE:** For **DISPLAY READY** QSI electronic modules only.

For the “Display Ready” QSI module, follow these initial instructions first to install your customer provided display to the cover plate in the kit. Then follow the Installation Instructions to install this customer-assembled unit to the meter.

1. Make sure the QSI module and meter are disconnected from power source.
2. **Remove batteries** from your display, they will no longer be needed.
3. Remove the pickup coil from the back center of your display by cutting the two wires that attach it to the display. Cut the wires as close to the display as possible to ensure the cut ends do not touch the PC board inside the QSI module. Discard the removed coil.
4. Using a small regular screwdriver, remove the clear sealant from the 10 pin female connector holes on the backside of your display.
5. Insert the “long legs” of the 10-pin male connector that came with the kit into the 10 pin female connector on the QSI circuit board (see Figure A).
6. Install the formed display seal into the seal gland on the backside of the display.
7. **CAREFULLY** mount the display onto the cover plate ensuring the legs of the male 10-pin connector are inserted into **ALL** 10 pin female connector holes of the display (see Figure B).
8. Secure the display to the cover plate using the four #4-20 x 7/8 in. tapping screws. Torque to 80-96 oz-in (0.56-0.67 Nm).

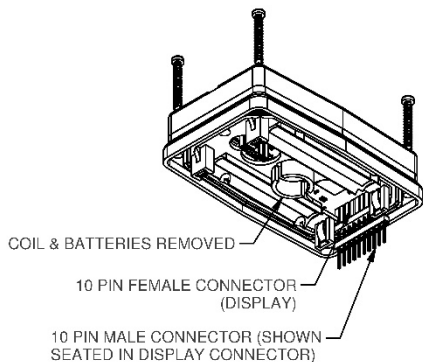

**Figure A**

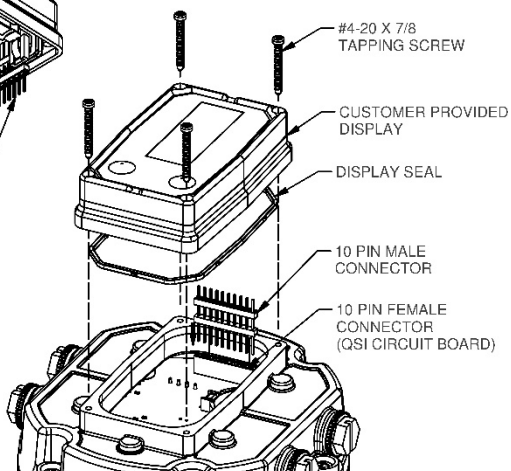

**Figure B**

## INSTALLATION

**NOTE:** For **ALL** electronic modules.

1. Make sure the QSI module and meter are disconnected from power source.
2. Remove any attached product, if it exists, from the top of your TM meter. It will be replaced with the module components.
3. Remove the (6) #8-16 x 3/4 in. screws attaching the module cover plate to the base and separate. Do not damage the seal between the two components (see Figure 2). The (2) wires connecting the QSI PC board to the screw terminal of the pick-up circuit board are long enough to allow separation of parts. The wires may be disconnected from the screw terminal if necessary. The wires are non-polarized and may be connected to either screw of the screw terminal (see Figure 4).
4. The module was packaged with the pickup coil in the unseated position to prevent coil damage during shipping. The coil has a foam spacer attached. Remove the liner from the foam spacer to expose the adhesive layer and adhere the plastic spacer to the foam spacer. Install the plastic spacer/coil into the adapter recess (see Figure 2).
5. Install the gasket received with the module on the bottom of the base. Mount the base to the TM meter, seating the pick-up coil in the meter recess. Secure base with (4) screws provided with the module. Tighten screws.
6. Make sure the seal is in place on top of the base prior to reattaching (if previously disconnected) the (2) wires to the screw terminal of the pick-up circuit board.
7. To route external power and/or electronic cables to the QSI PC board screw connectors, prepare the cover plate by removing the plug and sealing washer from each port that you intend to use. Replace the removed plugs with a strain relief w/O-ring. The strain relief will accommodate cable sizes of 0.11 in. (2.8 mm) through 0.26 in. (6.6 mm) diameter. Leave the factory installed plugs in any unused ports.
8. (Make sure the power is disconnected from external cables before beginning this step): Route external cables through the strain relief(s), and then tighten the dome nut securely around the cable to provide an environmental seal.
9. Connect cable wires to the QSI PC board screw connectors (see Figure 4, 6, or 8 depending on your module version).
10. Mount the cover plate on the base making sure the seal is seated properly between them. Replace the (6) previously removed screws to secure the cover plate to the base. Tighten screws.
11. Connect power to QSI module and meter.

**INSTALLATION (continued)**

**NOTE:** The below figure is for all QSI electronic modules, even though the “display ready” version is not shown in the pictorial.

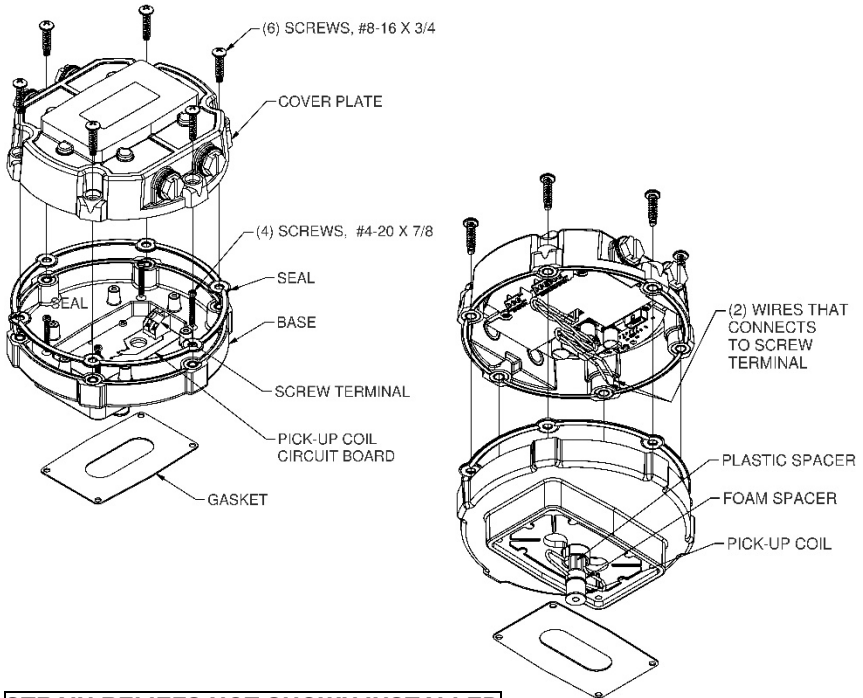

**STRAIN RELIEFS NOT SHOWN INSTALLED**

**Figure 2**



**WIRING DIAGRAMS**

**TERMINAL CONNECTIONS CHART**

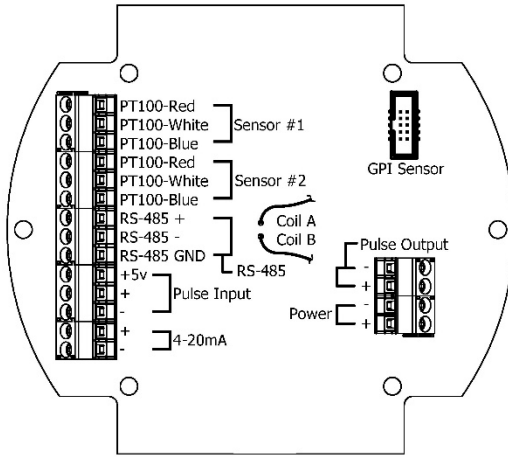

Figure 3

TEMP SENSOR	
PT100-Red	Sensor VCC Output
PT100-White	Input High Side
PT100-Blue	Input Return
RS-485 (Galvanically Isolated)	
RS485 (+)	Positive Signal
RS485 (-)	Negative Signal
RS485 GND	Circuit Ground*
PULSE INPUT	
+5V	5VDC output to power external sensor
(+)	Digital Pulse Frequency Input, up to 3kHz
(-)	Digital Pulse Return
4-20mA (Galvanically Isolated)	
(+)	4 to 20mA current loop-current in to transmitter
(-)	4 to 20mA current loop-current out of transmitter*

Coil A	Low level sine wave input
Coil B	Low level sine wave input
GPI SENSOR	
Ribbon cable connection to GPI custom sensor designs	
PULSE OUTPUT (Galvanically Isolated)	
(-)	Pulse Output return current*
(+)	Pulse Output frequency output. This is a "current sinking open collector" output ***
POWER INPUT	
(-)	12-36VDC Input A**
(+)	12-36VDC Input B**

**\*NOTE:** It is not recommended to connect isolated ground connections together or to board common.

**\*\*NOTE:** Polarity of voltage for DC is not important. However, an earth ground isolated power supply is required to prevent earth ground loop currents and ground fault conditions.

**\*\*\*NOTE:** This output may require an external pull up resistor if interfacing equipment does not include one.

**QSI1 WIRING**

**QSI VERSION 1 – PC BOARD**  
RS-485  
BTU

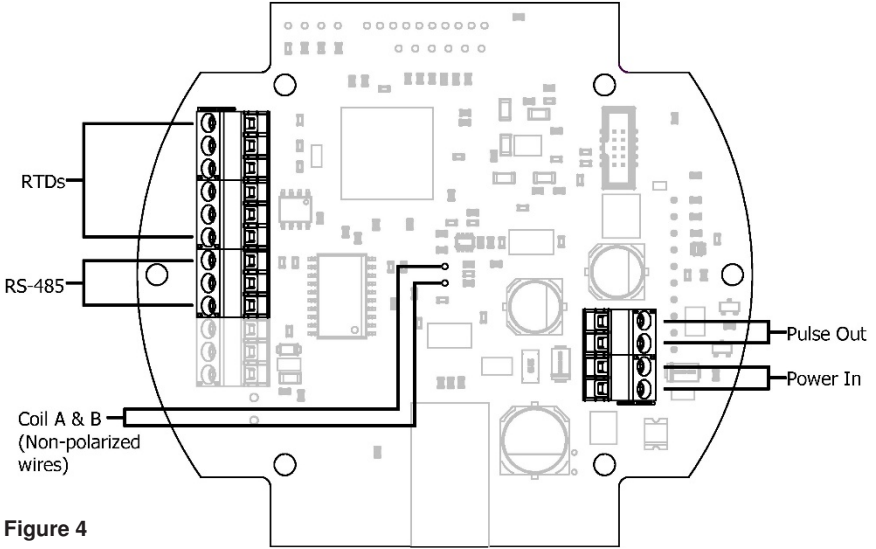

**Figure 4**

**QSI VERSION 1 - WIRING DIAGRAM**

Inputs: Temperature Sensors, Variable Reluctance, Pickup Coil  
Outputs: RS-485, Pulse Output

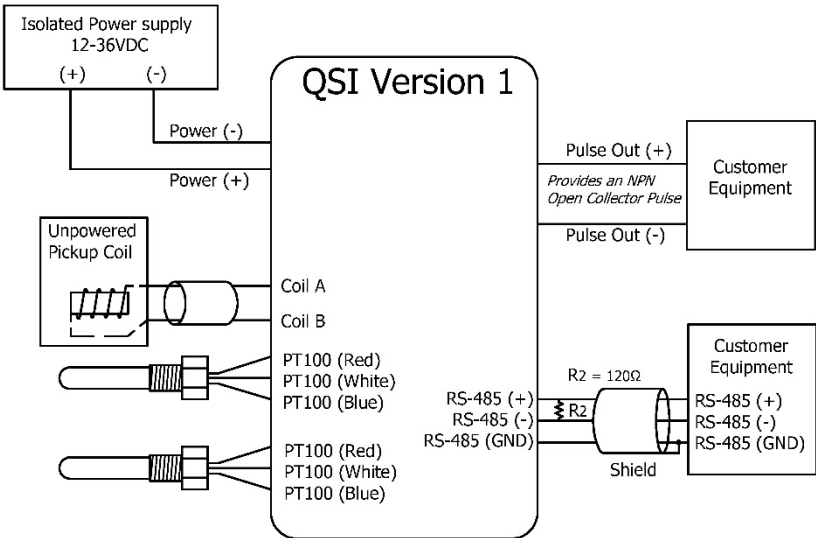
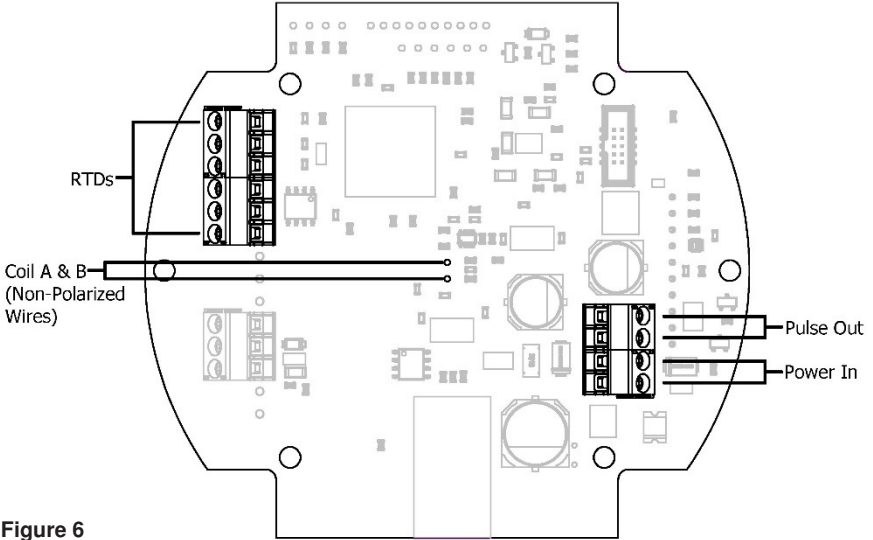

**Figure 5**

**QSI2 WIRING**

**QSI VERSION 2 – PC BOARD**

Pulse In  
BTU

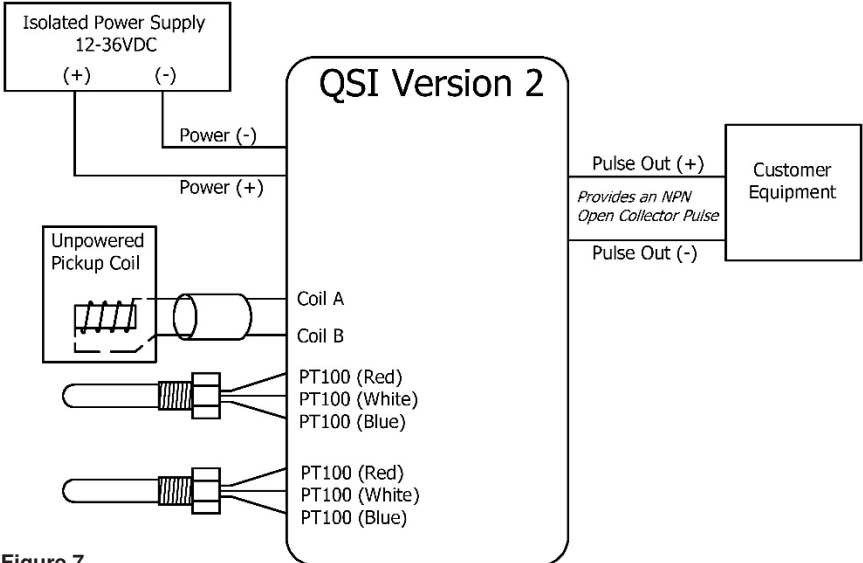

**Figure 6**

**QSI VERSION 2 - WIRING DIAGRAM**

Inputs: Temperature Sensors, Variable Reluctance, Pickup Coil

**Output: Pulse Output**



**Figure 7**

**QSI3 WIRING**

**QSI VERSION 3 – PC BOARD**  
4-20mA

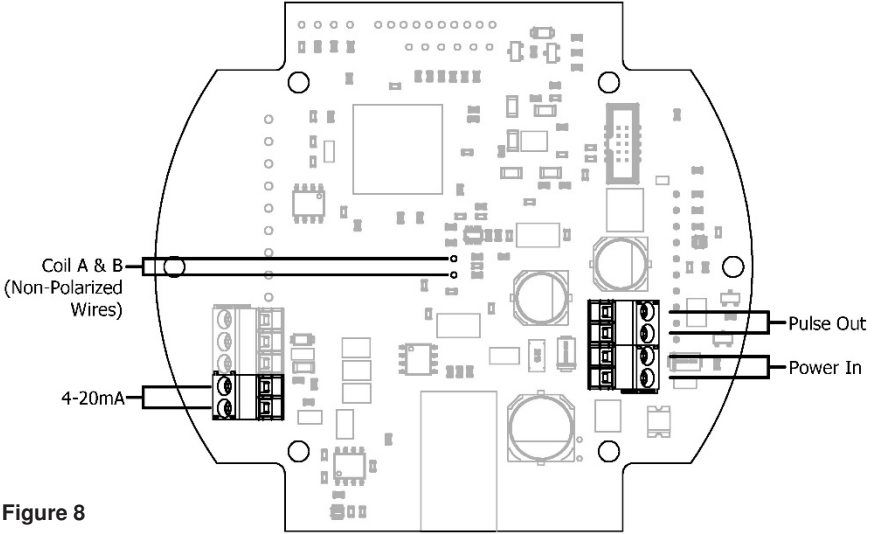

**Figure 8**

**QSI VERSION 3 - WIRING DIAGRAM**

**Customer Equipment with Built-in Power Supply**

Inputs: Standard Remote Sensor (Variable Reluctance Pickup Coil)

Outputs: Customer Equipment, 4-20mA Sensing, Built-in Loop Power Supply

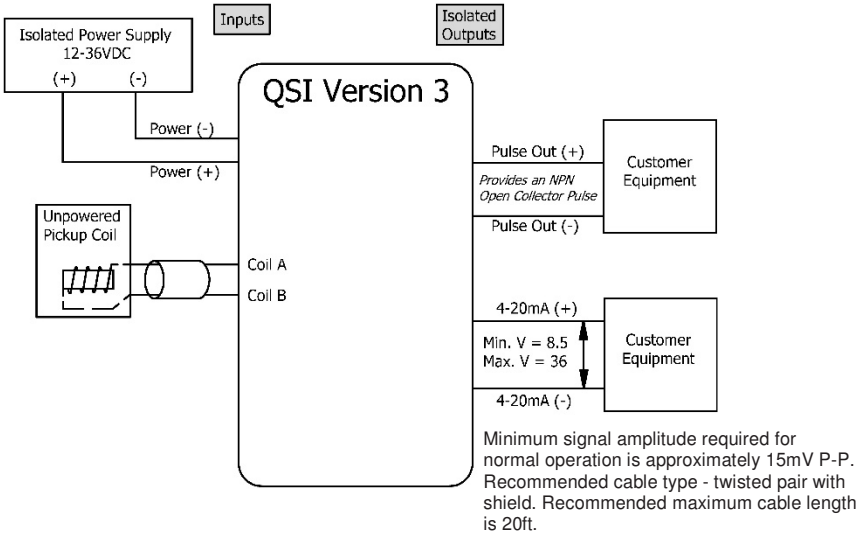

**CAUTION:** When reassembling the cover plate, make sure the enclosure seal is not crimped or twisted. Do not over-tighten screws (hand-tighten only).

**Figure 9**

**QSI3 WIRING - (continued)**

**QSI VERSION 3 - WIRING DIAGRAM**

**Customer Equipment without Built-in Power Supply**

Inputs: Standard Remote Sensor (Variable Reluctance Pickup Coil)

Outputs: 4-20mA with Separate Power Supply

**Note:** Either of the wiring diagrams below (**Low Side Negative Wiring-Figure 10A**) or (**High Side Positive Wiring-Figure 10B**) are valid, as long as the current direction arrows and the (+) and (-) connections on all of the equipment in the loop are correct.

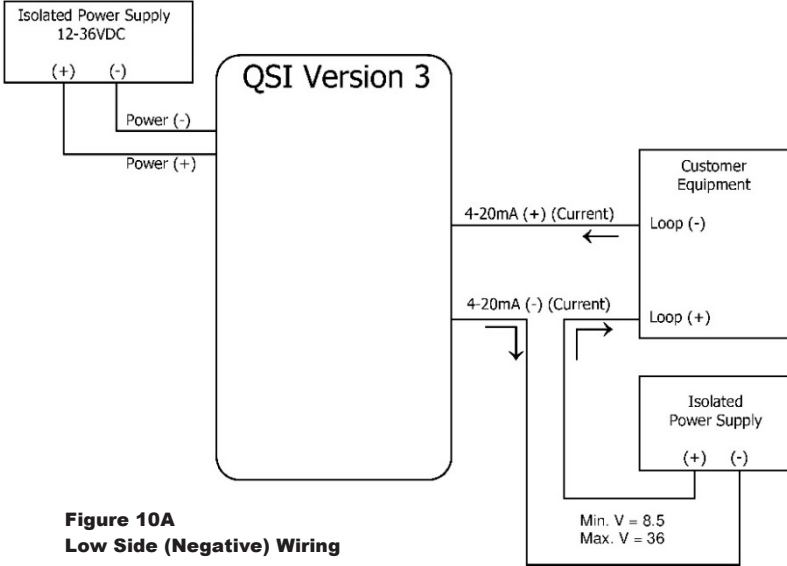

**Figure 10A**  
**Low Side (Negative) Wiring**

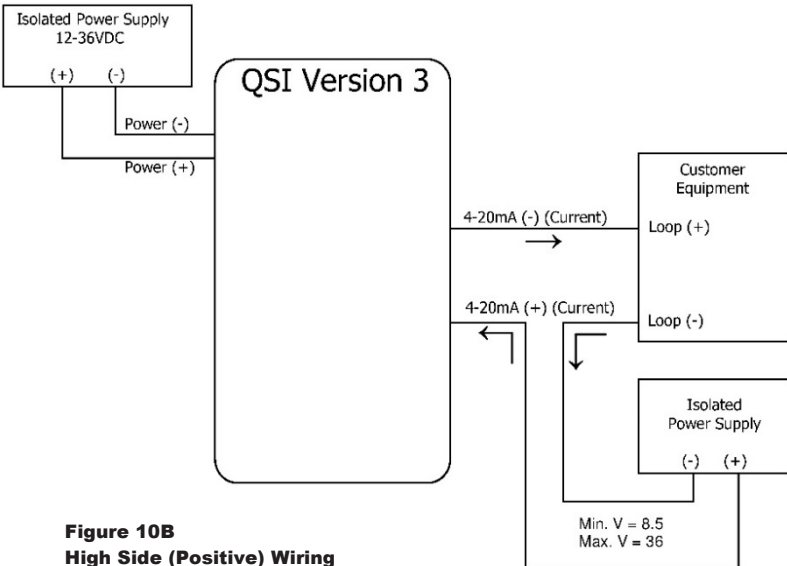

**Figure 10B**  
**High Side (Positive) Wiring**

## MAINTENANCE

Check cable-entry seals periodically. Tighten and/or apply sealant if needed. This is especially important in environments containing heavy concentrations of dust, oil mist, or other residue.

Check all wiring connections occasionally for oxidation or corrosion. Clean and re-seat if such conditions are noted.

If necessary, check and re-seat any connections that may have been subjected to strain (during rework or construction, for example).

## REPLACING BATTERY

**NOTE:** *The QSI2 and QSI3 communications module has a 3V lithium coin cell battery installed on the PC board. In case of power failure, the battery functions as power backup to maintain the internal system time. Any QSI2 or QSI3 feature that uses a time reference as part of its functionality will be immediately accurate to the current time when power is restored.*

To replace battery in “**NO DISPLAY**” MODULE:

- **DISCONNECT POWER TO METER**
- Remove (6) screws retaining the cover plate to the base and lift the cover plate free of the base (see Figure 11).
- Flip the cover plate over and remove (4) screws retaining the PC board assembly (see Figure 12).
- Remove and replace the coin cell battery (CR2032) on the backside of PC board (see Figure 13).
- Reverse the procedure to reassemble the cover plate to the base. Make sure the cover plate seal is seated before tightening the (6) cover plate screws.

To replace battery in “**DISPLAY READY**” MODULE:

**NOTE:** *On units with a display, only the display needs to be removed to replace the coin cell battery. The battery is accessible through the opening where the display is installed (see Figure 14).*

- **DISCONNECT POWER TO METER**
- Remove (4) screws retaining the display to the cover plate. Lift the display straight up to disconnect the 10-pin bridge connector. The bridge connector could disengage from either socket connector (display or PCB assembly) or both.
- Remove and replace the coin cell battery (CR2032).
- Reverse the procedure to reassemble the display to the cover plate. Make sure the display seal is seated before tightening the (4) display screws.

**MAINTENANCE (continued)**

**REPLACING BATTERY (continued)**

**STRAIN RELIEFS NOT SHOWN**

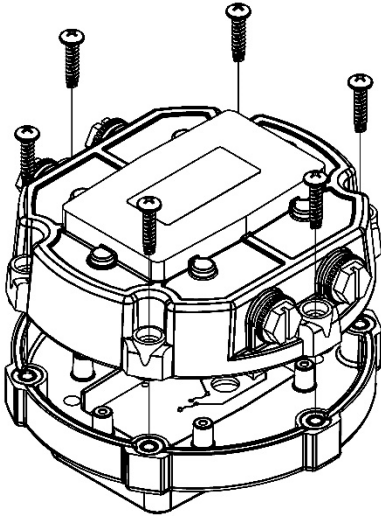

Figure 11

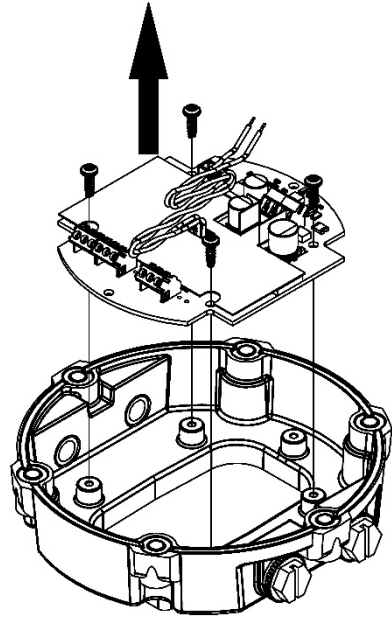
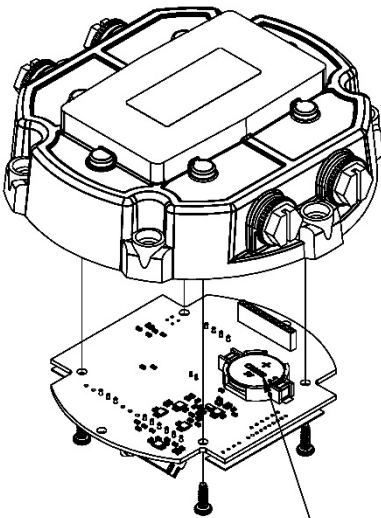
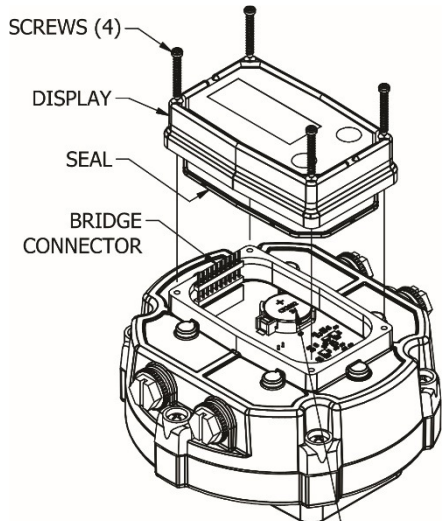

Figure 12



BATTERY (CR2032)

Figure 13



BATTERY (CR2032)

Figure 14

## SERVICE

For warranty consideration, contact your local distributor. If you need further assistance, contact the GPI Customer Service Department at:

**1-888-996-3837**

You will need to:

- Provide information from the decal on your meter.
- Receive a Return Authorization number.
- Flush any fluid from the meter before shipping to the factory.

## RETURNING PARTS

Please contact the factory before returning any parts. It may be possible to diagnose the trouble and identify needed parts in a telephone call. GPI can also inform you of any special handling requirements you will need to follow covering the transportation and handling of equipment that has been used to transfer hazardous or flammable liquids.

**CAUTION:** *Do not return equipment without specific authority from the GPI Customer Service Department. Due to strict regulations governing transportation, handling, and disposal of hazardous or flammable liquids, GPI will not accept equipment for rework unless it is completely free of liquid residue.*











**FLOMEC® TWO-YEAR LIMITED WARRANTY**

Great Plains Industries, Inc. 5252 E. 36th Street North, Wichita, KS USA 67220-3205, hereby provides a limited warranty against defects in material and workmanship on all products manufactured by Great Plains Industries, Inc. This product includes a 2-year warranty. Manufacturer’s sole obligation under the foregoing warranties will be limited to either, at Manufacturer’s option, replacing or repairing defective Goods (subject to limitations hereinafter provided) or refunding the purchase price for such Goods theretofore paid by the Buyer, and Buyer’s exclusive remedy for breach of any such warranties will be enforcement of such obligations of Manufacturer. The warranty shall extend to the purchaser of this product and to any person to whom such product is transferred during the warranty period.

The warranty period shall begin on the date of manufacture or on the date of purchase with an original sales receipt. This warranty shall not apply if:

- A. the product has been altered or modified outside the warrantor’s duly appointed representative;
- B. the product has been subjected to neglect, misuse, abuse or damage or has been installed or operated other than in accordance with the manufacturer’s operating instructions.

To make a claim against this warranty, or for technical assistance or repair, contact your FLOMEC distributor or contact FLOMEC at one of the locations below.

In North or South America contact

**Great Plains Industries, Inc.**  
5252 East 36<sup>th</sup> St. North  
Wichita, KS 67220-3205  
USA

**888-996-3837**

**www.flomecmeters.com**  
**(North America)**

Outside North or South America contact

**GPI Australia**  
**(Trimec Industries Pty. Ltd.)**  
12/7-11 Parraweena Road  
Caringbah NSW 2229  
Australia

**+61 02 9540 4433**

**www.flomec.com.au**

The company will step you through a product troubleshooting process to determine appropriate corrective actions.

GREAT PLAINS INDUSTRIES, INC., EXCLUDES LIABILITY UNDER THIS WARRANTY FOR DIRECT, INDIRECT, INCIDENTAL AND CONSEQUENTIAL DAMAGES INCURRED IN THE USE OR LOSS OF USE OF THE PRODUCT WARRANTED HEREUNDER.

The company herewith expressly disclaims any warranty of merchantability or fitness for any particular purpose other than for which it was designed.

This warranty gives you specific rights and you may also have other rights which vary from U.S. state to U.S. state.

NOTE: In compliance with MAGNUSON MOSS CONSUMER WARRANTY ACT – Part 702 (governs the resale availability of the warranty terms).

Wichita / Sydney



© 2021 Great Plains Industries, Inc., All Rights Reserved.  
Great Plains Industries, Inc. / 888-996-3837 / flomecmeters.com