

# INSTRUCTION MANUAL

**BilgMon488**  
15 ppm Bilge Alarm

## Table of Contents

1. Table of validity.....	3
2. Introduction.....	4
3. Construction.....	4
4. Operation.....	5
5. Caution.....	5
6. Specification.....	6
6.1. General.....	6
6.2. Specific 115/230 V AC model.....	7
6.3. Specific 24 V AC/DC model.....	7
7. Installation.....	8
8. Calibration.....	14
8.1. Calibration certificate expiration.....	14
8.2. Calibration check requirements.....	14
9. Operating Instructions.....	15
10. Simulation.....	26
11. Contrast.....	26
12. Automatic stopping device test.....	27
12.1. While separator is active.....	27
12.2. While separator is not active.....	27
13. Response test.....	27
13.1. Step 1.....	27
13.2. Step 2.....	27
13.3. Alternative.....	27
14. Calibration check (40 NTU).....	28
15. Log entries.....	29
16. Maintenance.....	30
17. Spare parts list.....	31
18. Troubleshooting.....	33



### Brännströms Elektronik AB

Uddevallagatan 14  
416 70 Göteborg  
Tfn: +46 31 19 56 00  
Fax: +46 31 19 77 90

## 1. Table of validity

The following table describes the software and hardware versions on which this document was based.

<i>Doc version</i>	<i>MASTER SW ver.</i>	<i>MASTER PCB ver.</i>	<i>SENSOR SW ver.</i>	<i>SENSOR PCB ver.</i>
vN	A3	Bilgbas_H.1/ Bilgbaslv_C.1 Bilgemaster L.1	F	Bilgemon H.1
vO, vP	A4	Bilgbas_H.1/ Bilgbaslv_D.1 Bilgemaster L.1	B2	Bilgemon J.1
vQ, vR	A4	Bilgbase_H.1/ Bilgbaslv_D.1/ Bilgbasco_A Bilgemaster L.1	B2	Bilgemon J.1
vS, vT	A9	Bilgbase_I.1/ Bilgbaslv_D.1/ Bilgbasco_A Bilgemaster N.1	B5	Bilgemon J.1



### **Brännströms Elektronik AB**

Uddevallagatan 14  
416 70 Göteborg  
Tfn: +46 31 19 56 00  
Fax: +46 31 19 77 90

[info@brannstrom.se](mailto:info@brannstrom.se) ♦ [www.brannstrom.se](http://www.brannstrom.se)

## 2. Introduction

The BilgMon488 bilge alarm has been designed specifically for use in conjunction with 15 ppm oil-water separator units. BilgMon488 performance meets the requirements of the International Maritime Organisation specifications for 15 ppm bilge alarms contained in resolution MEPC. 107(49).

BilgMon488 is equipped with 2 adjustable alarms that are triggered when the oil-content of the processed sample exceeds the set limit (1 – 15 ppm, works-adjusted to 15ppm). Alarm outputs consist of relays and indicator LEDs. Additionally a 0(4) – 20 mA current output signal (corresponding to 0 – 30 ppm) is available to enable remote surveillance and recording of oil contents.

Downloading the operating log of BilgMon488 can be done through a USB-interface. This requires driver software and cables that can be supplied on demand.

## 3. Construction

BilgMon488 consists of two main parts, the MASTER unit (housing with LCD, buttons and LEDs) and the SENSOR unit (housing with pipe fittings).

The MASTER unit contains all the electronics used for control and data storage of the bilge alarm. Mounted in the lid of the MASTER housing is the main memory containing the bilge alarm log.

The SENSOR unit contains electronics for measuring the sample stream. The SENSOR unit also holds the measurement calibration data. Communication with the MASTER unit is done wireless hence the SENSOR unit is hermetically sealed and shall not be opened.



### **Brännströms Elektronik AB**

Uddevallagatan 14  
416 70 Göteborg  
Tfn: +46 31 19 56 00  
Fax: +46 31 19 77 90

## 4. Operation

Optical sensors monitors the amount of light scattered and absorbed by the oil droplets in the sample stream. Sensor signals are processed by a microprocessor to produce a corresponding oil content (ppm) output. The output is communicated to the MASTER unit where it is processed. The MASTER unit takes action, such as alarm activation, logging etc., depending on the oil content and the separator signal.

Settings that affect the behaviour of the bilge alarm are described in detail in the "Operating Instructions" section.

Zero point calibration can be re-adjusted on site whereas full sensor calibration according to IMO-requirements is performed by manufacturer.

## 5. Caution

The lid of the MASTER unit contains a small battery (watch battery). This battery enables the BilgMon488 to keep track of time and date (real time clock, RTC).

**Do NOT** under any circumstance remove this battery as it will cause a unrecoverable error ("RTC check FAILED!!").

**Do NOT** open the SENSOR unit as this will invalidate the calibration.

**Do NOT** open the MASTER unit when it is energized. Hazardous voltages are present inside.



### **Brännströms Elektronik AB**

Uddevallagatan 14  
416 70 Göteborg  
Tfn: +46 31 19 56 00  
Fax: +46 31 19 77 90

*info@brannstrom.se ♦ www.brannstrom.se*

## 6. Specification

### 6.1. General

#### *Measurement:*

Oil range:	0 – 30 ppm
Resolution:	0.1 ppm
Accuracy:	According to IMO MEPC.107(49)
Response time:	< 3 sec

#### *Alarms:*

Alarm 1 (valve control) delay:	0-10 sec user adjustable
Alarm 2 (annunciation) delay:	0-600 sec user adjustable
Alarm points 1 and 2:	1-15 ppm user adjustable
Alarm hysteresis:	0.5 ppm (below alarm point)

#### *Data storage and retrieval:*

Calibration storage:	Stored in sensor housing.
IMO required data:	Stored in BilgMon488 main housing (sensor housing may be replaced with data remaining on board).
IMO required data retrieval:	Via LCD display, USB.

#### *User interface:*

LCD display:	2x16 alphanumeric display
Control:	4 button keypad



### **Brännströms Elektronik AB**

Uddevallagatan 14  
416 70 Göteborg  
Tfn: +46 31 19 56 00  
Fax: +46 31 19 77 90

## 6.2. Specific 115/230 V AC model

### *Input/Output:*

Current output:	0 – 20 mA or 4 – 20 mA for 0 – 30 ppm
Communications:	USB serial communication (separate cable and software)
Alarm outputs:	2 x relays (0.25A)
Clean water solenoid valve output:	1 x relay (0.5A, supply voltage)
Switch input:	1 x switch input for separator status

### *System and supply:*

Supply:	1 A, 115 or 230 V AC, 50 – 60 Hz
Power consumption electronics:	10 VA
Power consumption solenoid:	18 VA

## 6.3. Specific 24 V AC/DC model

### *Input/Output:*

Current output:	0 – 20 mA or 4 – 20 mA for 0 – 30 ppm
Communications:	USB serial communication (separate cable and software)
Alarm outputs:	2 x relays (1A)
Clean water solenoid valve output:	1 x relay (1A, supply voltage)
Switch input:	1 x switch input for separator status

### *System and supply:*

Supply:	1.5 A, 24 V AC (50 – 60 Hz) or 24 V DC
Power consumption electronics:	10 VA
Power consumption solenoid:	18 VA



### **Brännströms Elektronik AB**

Uddevallagatan 14  
416 70 Göteborg  
Tfn: +46 31 19 56 00  
Fax: +46 31 19 77 90

## 7. Installation

### Mechanical

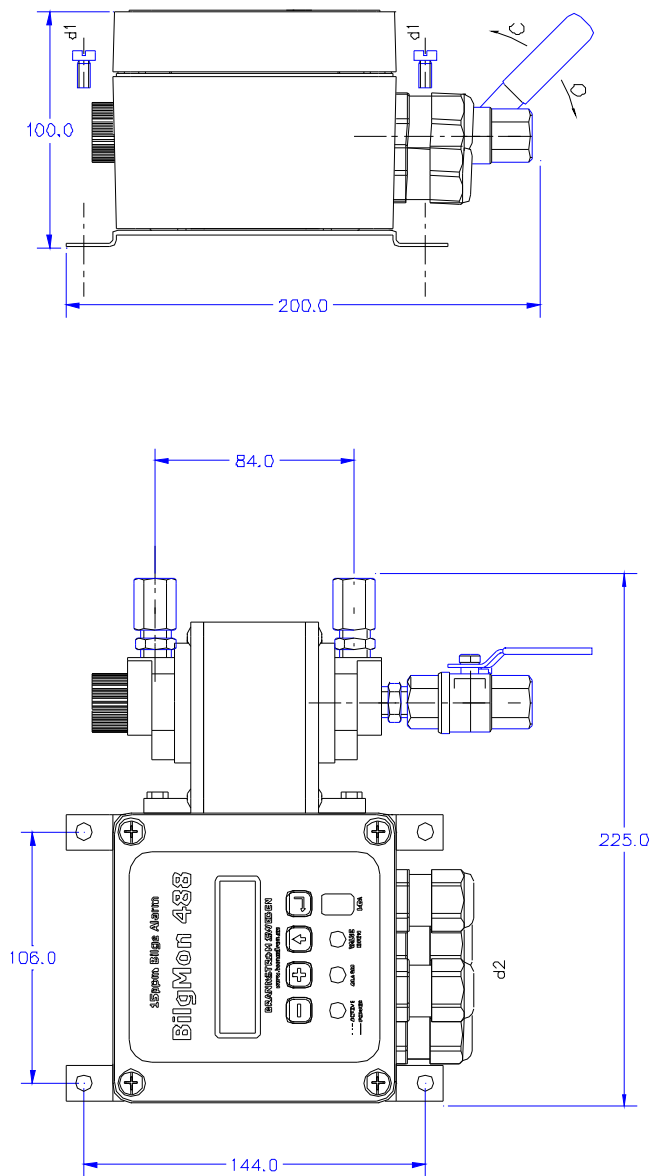

### Brännströms Elektronik AB

Uddevallgatan 14  
416 70 Göteborg  
Tfn: +46 31 19 56 00  
Fax: +46 31 19 77 90

[info@brannstrom.se](mailto:info@brannstrom.se) ♦ [www.brannstrom.se](http://www.brannstrom.se)



Tube arrangement alt 1

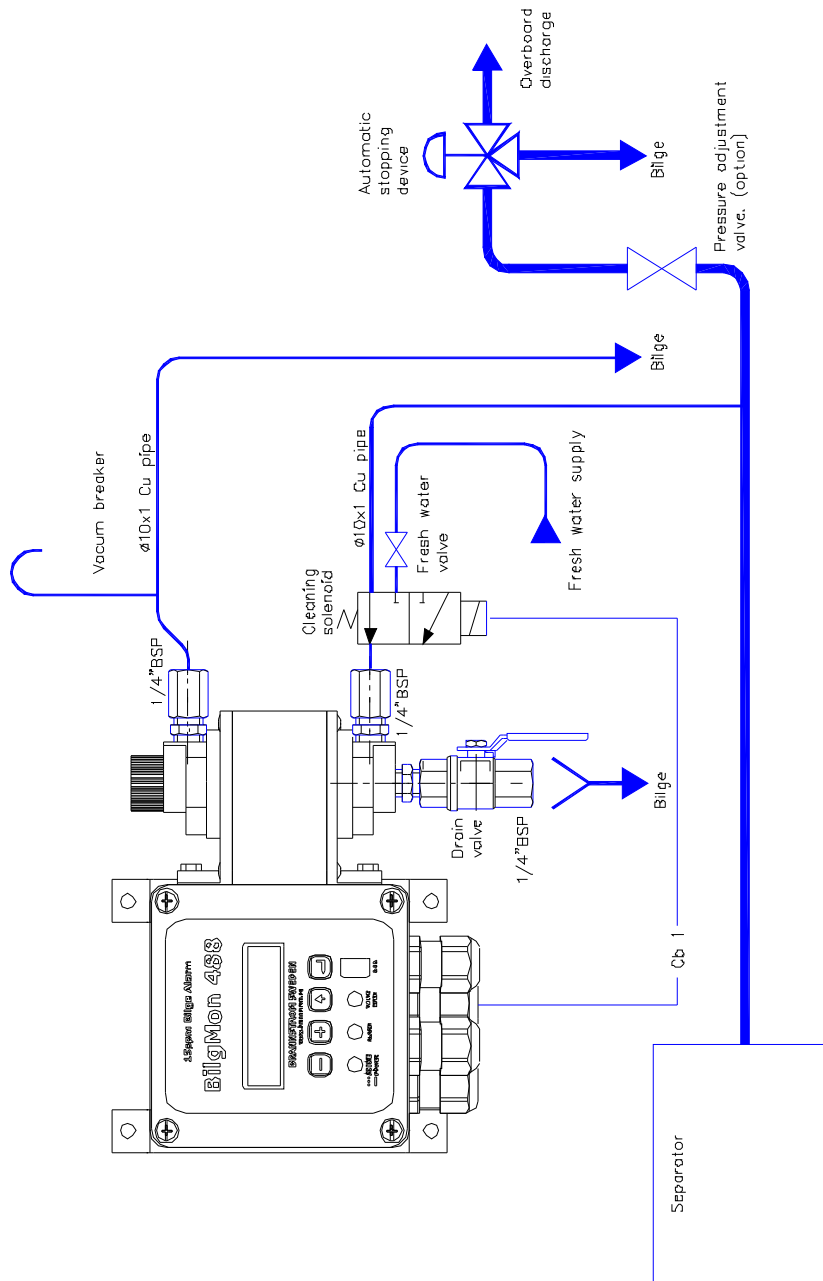

**Brännströms Elektronik AB**

Uddevallgatan 14  
 416 70 Göteborg  
 Tfn: +46 31 19 56 00  
 Fax: +46 31 19 77 90

info@brannstrom.se ♦ www.brannstrom.se

3-way solenoid valve mounting (Tube arrangement alt 1).

**NOTE (115/230 VAC model):** There are two coils delivered with the BilgMon 488 one to be used with 110 VAC (marked 96 V) and one to be used with 220 VAC (marked 205 V). Be shure to install the proper one for the choosen voltage.

**NOTE (24 VAC/DC model):** Only one coil delivered with this model (marked 24 V).

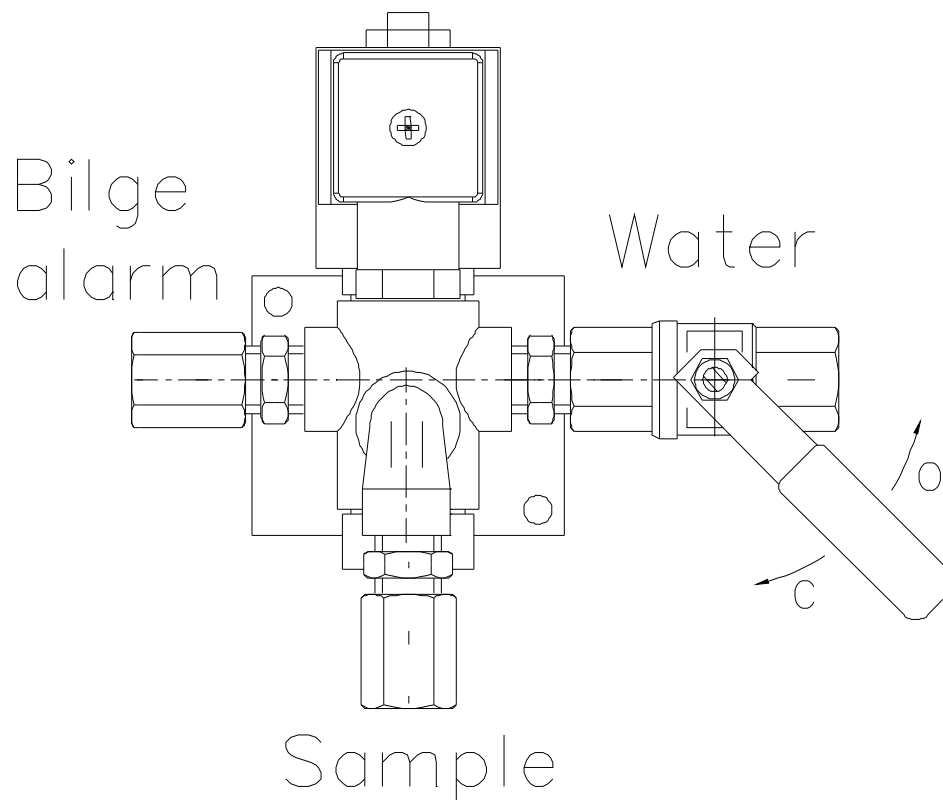

**Brännströms Elektronik AB**

Uddevallagatan 14  
416 70 Göteborg  
Tfn: +46 31 19 56 00  
Fax: +46 31 19 77 90

*info@brannstrom.se* ♦ *www.brannstrom.se*

Tube arrangement alt 2

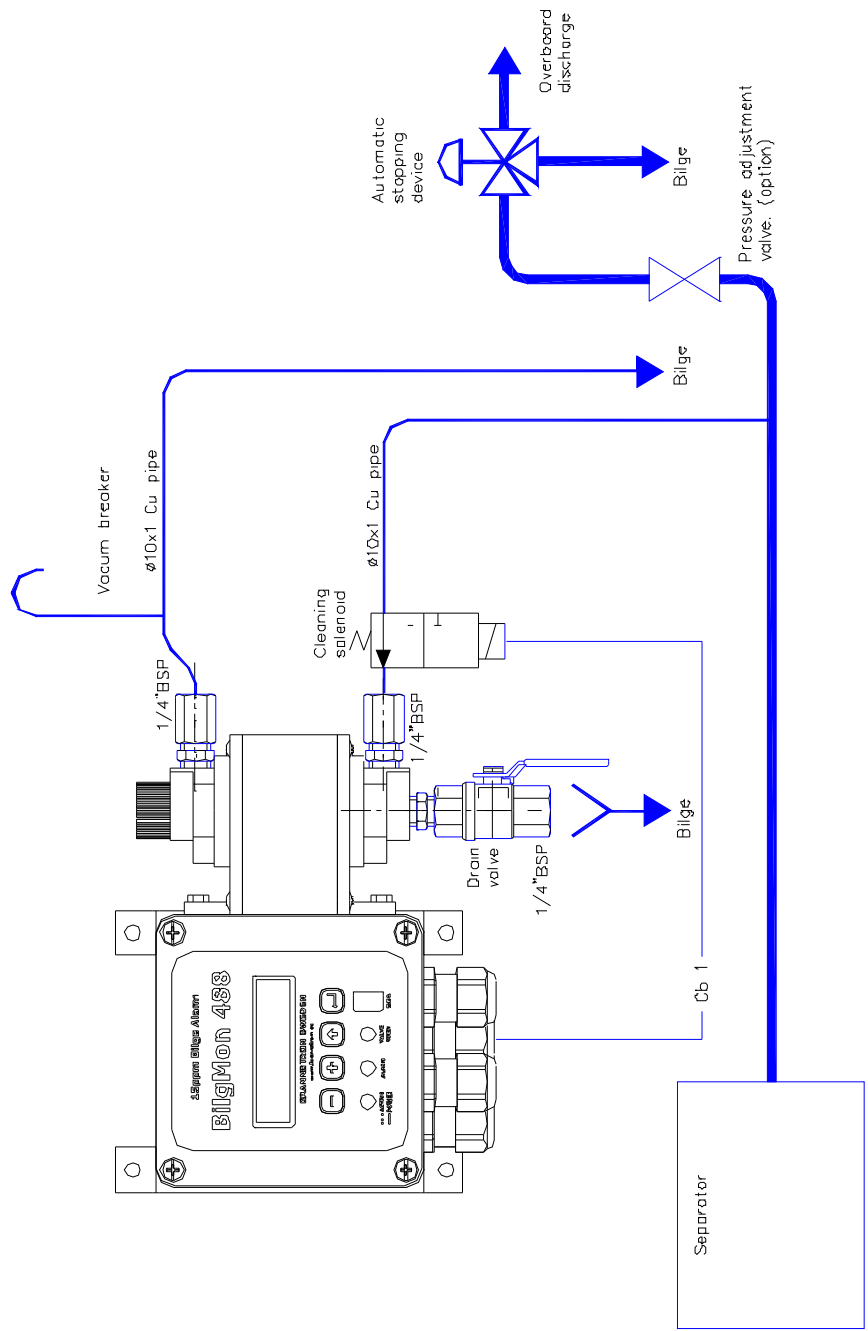

**Brännströms Elektronik AB**

Uddevallagatan 14  
 416 70 Göteborg  
 Tfn: +46 31 19 56 00  
 Fax: +46 31 19 77 90

info@brannstrom.se ♦ www.brannstrom.se

Tube arrangement alt 3

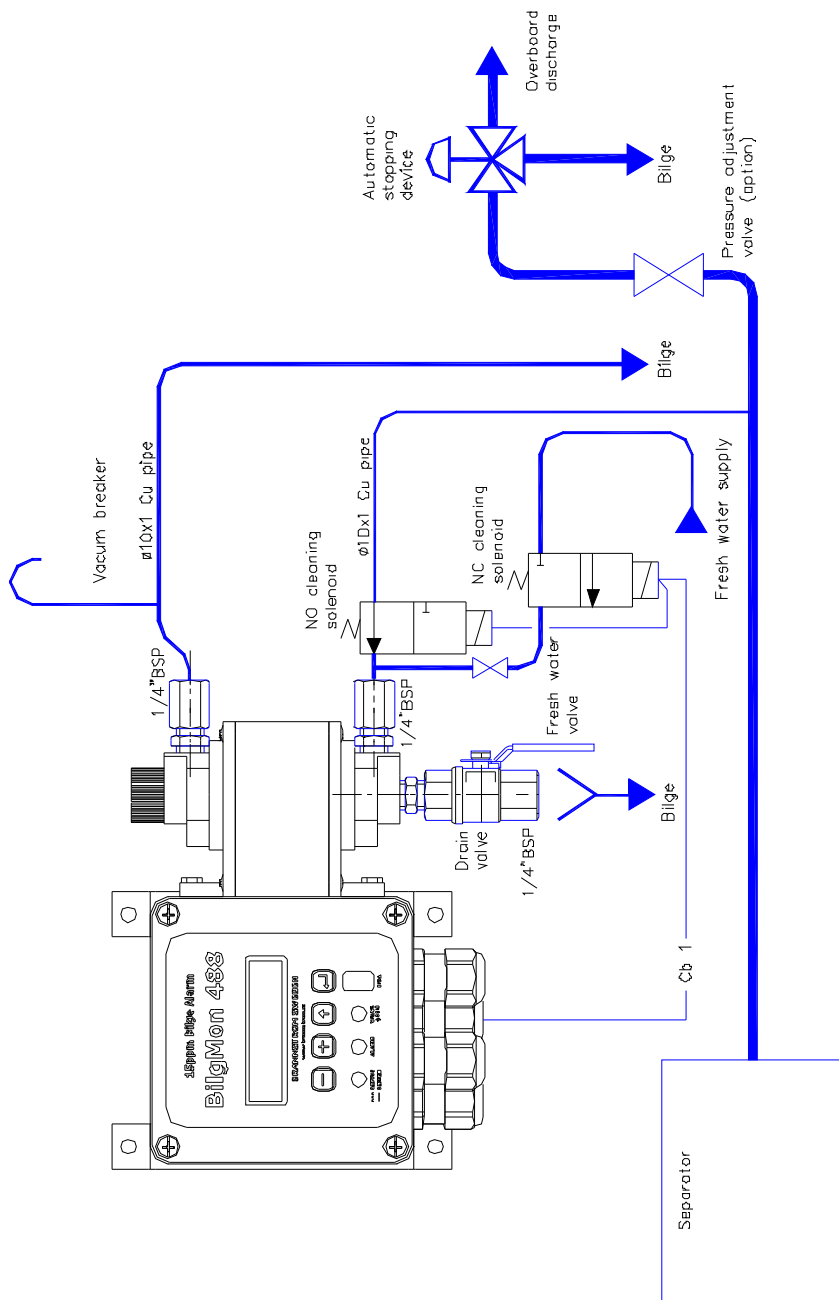

**Brännströms Elektronik AB**

Uddevallagatan 14  
 416 70 Göteborg  
 Tfn: +46 31 19 56 00  
 Fax: +46 31 19 77 90

info@brannstrom.se ♦ www.brannstrom.se

Electrical connections  
115VAC/230VAC

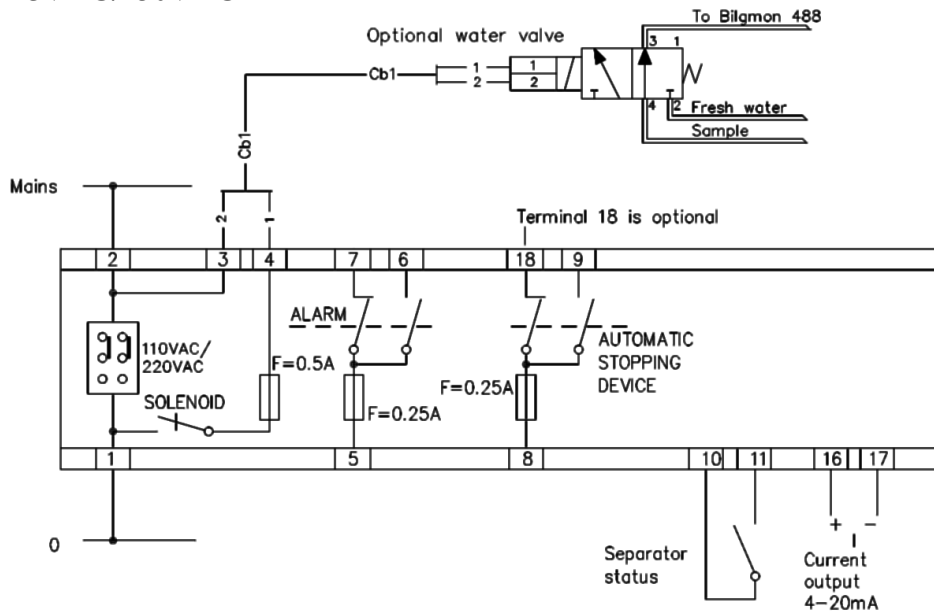

24V AC/DC

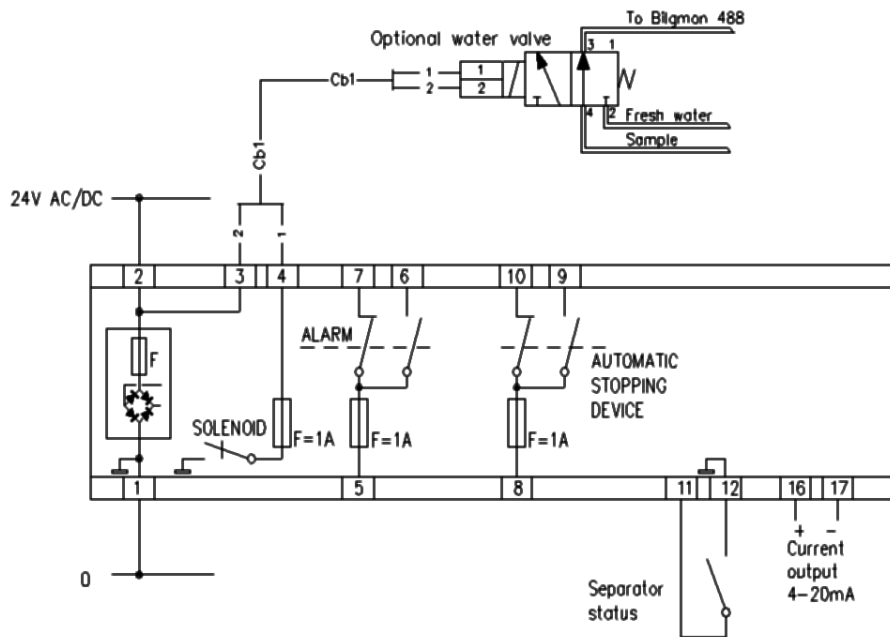

**Brännströms Elektronik AB**

Uddevallagatan 14  
416 70 Göteborg  
Tfn: +46 31 19 56 00  
Fax: +46 31 19 77 90

info@brannstrom.se ♦ www.brannstrom.se

## 8. Calibration

Two items needs to be addressed when setting up the maintenance schedule for the BilgMon488:

- The calibration certificate expiration of the SENSOR unit.
- On occasions “calibration check” is required on a more regular basis.

The following two subchapters explain how to resolve these two items.

### 8.1. Calibration certificate expiration

If the calibration certificate expires the SENSOR unit must be replaced. The SENSOR of BilgMon488 is designed to be easily replaced by the crew. Replacement does not require any adjustments of the MASTER unit setup. Each new SENSOR is accompanied with a new calibration certificate.

### 8.2. Calibration check requirements

On occasion ships may be required to perform a “calibration check” on their units. This might be required to take place at shorter intervals than the calibration certificate validity period.

Calibration check can be achieved in the following ways:

1. Checking calibration with a “Calibration Check Kit”.  
(Requires ordering a kit or consult a service agent)
2. If the calibration check fails (calibration check values are not within limits), a new SENSOR must be installed.



#### **Brännströms Elektronik AB**

Uddevallagatan 14  
416 70 Göteborg  
Tfn: +46 31 19 56 00  
Fax: +46 31 19 77 90

## 9. Operating Instructions

The menu system of BilgMon488 is organised into 4 top menus:

1. *Main menu.*
2. *Info menu.*
3. *Log menu.*
4. *Cleaning/test menu.*
5. *Settings menu.*

Some of the menus also contain submenus for displaying or setting the properties of the apparatus.

Navigating the menus is done by using the 4 push buttons located beneath the LCD display. In this document they are referred to as (from left to right) MINUS, PLUS, ABORT and ENTER. LONG\_ENTER means keeping the ENTER button pressed for more than 2 seconds. By using the above mentioned buttons the user is able to navigate menus, enter values and activate different functions of the BilgMon488 .



### **Brännströms Elektronik AB**

Uddevallagatan 14  
416 70 Göteborg  
Tfn: +46 31 19 56 00  
Fax: +46 31 19 77 90

*info@brannstrom.se ♦ www.brannstrom.se*

- **Main menu**

After start the display will show the *main menu*. The apparatus can only be activated when the display shows the *main menu* hence the user has to be sure that the apparatus is left in the *main menu* state after performing settings, cleaning, tests etc. Contrast of the LCD screen can be adjusted by holding the ABORT button while adjusting with PLUS and MINUS when in *main menu*. Note that the apparatus will return to the main menu after 5 min of no activity (no pressed buttons). The bilge alarm can only be activated when in *main menu*. In all other menus the overboard valve will be closed.

- **Info menu**

The submenus of *info menu* show information about the master unit (software version and part ID) and the sensor unit (part ID, SW version, sensor birth date and date of last calibration check). Note that entering the submenus also puts the apparatus in an alarm state.

- **Log menu**

The *log menu* contains functionality for searching and stepping the logged IMO required data.

- **Cleaning & test menu**

The *cleaning & test menu* and its submenus provide measures for calibrating, cleaning and testing the apparatus.

- **Settings menu**

*Settings menu* contains adjustable settings of parameters such as ppm-limits, alarm/valve time delays, autoflush settings, clock and current output (curro) mode.



**Brännströms Elektronik AB**

Uddevallagatan 14  
416 70 Göteborg  
Tfn: +46 31 19 56 00  
Fax: +46 31 19 77 90

[info@brannstrom.se](mailto:info@brannstrom.se) ♦ [www.brannstrom.se](http://www.brannstrom.se)



The menu system of BilgMon 488 is depicted in the following figure:

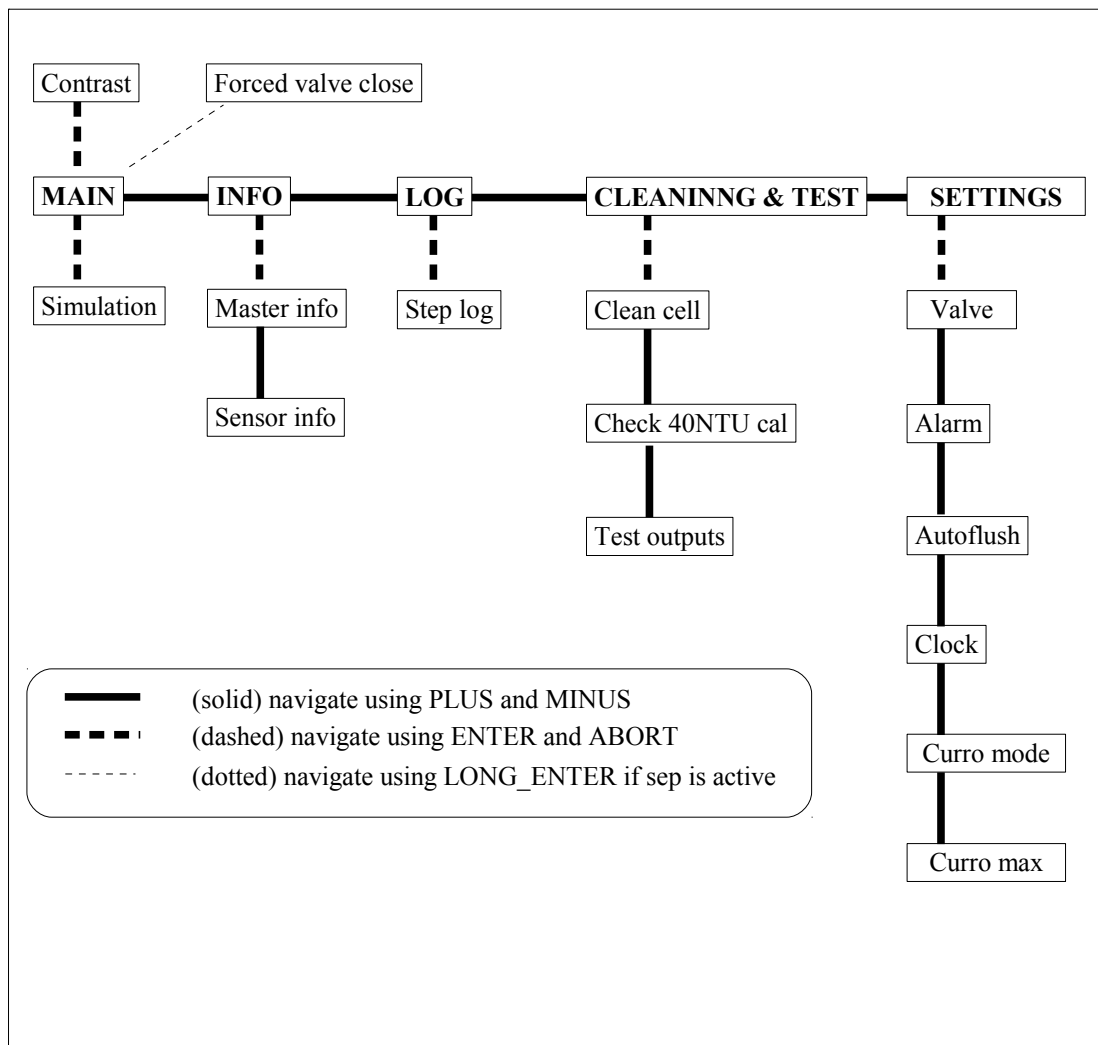

**Brännströms Elektronik AB**

Uddevallagatan 14  
 416 70 Göteborg  
 Tfn: +46 31 19 56 00  
 Fax: +46 31 19 77 90

*info@brannstrom.se ♦ www.brannstrom.se*

The following table shows the different menus and submenus of the BilgMon488 and detailed instructions on how to operate them.

<pre>050327 10:06:00 PPM=07.2 SPL</pre>		
<p>The "main menu" is displayed at startup. The values shown in this menu are date, time, the measured oil-content of the sample in parts per million (ppm) and the position of the clean water valve (SPL = sample, WTR = clean water).</p> <p>Press PLUS to go to next menu.</p> <p>Return to this menu by pressing ABORT several times.</p> <p>If the second row shows "Lost sensor com!" see section Troubleshooting.</p> <p>If the alarm is on (when unit is active) the user can acknowledge it by pressing one of the buttons.</p> <p>Acknowledging will turn off the alarm output but the alarm led will remain lit until the PPM-value is below the set alarm limit.</p>		



### Brännströms Elektronik AB

Uddevallagatan 14  
416 70 Göteborg  
Tfn: +46 31 19 56 00  
Fax: +46 31 19 77 90

[info@brannstrom.se](mailto:info@brannstrom.se) ♦ [www.brannstrom.se](http://www.brannstrom.se)

Info	Master info	
<p>The "info menu" and its submenus contain information about the system such as software versions, ID-numbers etc. To enter the info submenus press ENTER. Press PLUS to go to next menu. Return to this menu by pressing ABORT several times.</p>	<p>Continuous cycles with information about the master unit (se right column). Press MINUS to go to previous submenu. Press PLUS to go to next submenu. Press ABORT to exit the submenu.</p>	<p>Master info</p> <p>Master ID: AC02-2321</p> <p>Master SW ver: 000A</p>
	Sensor info	
	<p>Continuous cycles with information about the sensor unit (se right column). Press MINUS to go to previous submenu. Press ABORT to exit the submenu.</p>	<p>Sensor info</p> <p>Sensor ID: CD12-4541</p> <p>Sensor SW ver: 000B</p> <p>Sensor date: 050219 15:20:00</p> <p>Cal. checked: 050220 10:00:00</p> <p>T:25.3 Dry:60 V3:3.20 V03:.312</p>

**Brännströms Elektronik AB**

Uddevallagatan 14  
416 70 Göteborg  
Tfn: +46 31 19 56 00  
Fax: +46 31 19 77 90

Log 1043 entries	Log: PPM > 15 050223 13:32:12	Log: Search for: 050223 13:32:12
<p>The "log menu" shows the number of events/entries currently available in the log memory.</p> <p>To enter the log submenu press ENTER (only possible if log is not empty).</p> <p>Press PLUS to go to next menu or MINUS to go to previous.</p>	<p>The "step log menu" lets the user step through the apparatus log displaying the event, date and time of the log entries.</p> <p>Step backwards (in time) by pressing MINUS and forward by pressing PLUS. Enter search mode by pressing ENTER (se right). Return to "log menu" by pressing ABORT.</p> <p>When returning from this menu the user will be asked "Send log?". This provides the possibility to send data to the USB port of the apparatus. Answer the question by pressing the button corresponding to the desired answer.</p>	<p>The "search log menu" lets the user search for a specific date in the log. Note that a cursor is shown under the item currently edited.</p> <p>Move cursor by pressing ENTER. Increase/decrease value by pressing PLUS/MINUS. Commit search by pressing LONG_ENTER (return to "step log menu" with result of search).</p> <p>Abort search by pressing ABORT (return to "step log menu").</p>



### Brännströms Elektronik AB

Uddevallagatan 14  
416 70 Göteborg  
Tfn: +46 31 19 56 00  
Fax: +46 31 19 77 90

Cleaning & test	Clean cell: START	Zero value: 040% WTR ZERO
<p>To enter the "cleaning and test" submenus press ENTER.</p> <p>Press PLUS to go to next menu or MINUS to go to previous. ABORT returns to "main menu".</p>	<p>Press ENTER to enter the cleaning mode (se right). Press PLUS to go to next submenu and ABORT to exit the submenu.</p>	<p>The cleaning mode lets the user unscrew the cap of the sensor housing and clean the sensor using water and a soft brush.</p> <p>The water valve can be opened and closed by pressing MINUS.</p> <p>When the sensor tube is clean enough the "zero value" will be below 50% when running clean water through the sensor.</p> <p>Pressing ENTER when "ZERO" is displayed zero calibrates the sensor.</p>
	Check 40NTU cal: START	Cal value: 083% OK
	<p>Press ENTER to enter the check 40NTU calibration mode (se right). Press PLUS to go to next submenu or MINUS to go to previous.</p> <p>Press ABORT to exit the submenu.</p>	<p>Fill the sensor with 40NTU reference fluid. If the sensor is correctly calibrated the calibration value displayed should be above 80%. Pressing ENTER (OK) when the calibration value is displayed sets the calibration check date (shown in "sensor info" submenu) to current date.</p>

**Brännströms Elektronik AB**

Uddevallagatan 14  
416 70 Göteborg  
Tfn: +46 31 19 56 00  
Fax: +46 31 19 77 90

	<div style="border: 1px solid black; padding: 2px; text-align: center;">                 Test outputs:                  START             </div>	<div style="border: 1px solid black; padding: 2px; text-align: center;">                 ALM VLV WTR C                  OFF 09 OFF EXIT             </div>
	<p>Press ENTER to enter the automatic cleaning mode (se right).                  Press MINUS to go to previous submenu.                  Press ABORT to exit the submenu.</p>	<p>The test outputs lets the user toggle the relay outputs of the BilgMon488. Press MINUS/PLUS/ABORT to toggle the states of valve-/alarm-/water-relay. Note that a time limit is used for the water- and valve-relays. Two relays can not be activated simultaneously. In the top right corner of the LCD an indication of the input signal is shown ("C" means closed and "O" means open).                  Exit by pressing ENTER.</p>



**Brännströms Elektronik AB**

Uddevallagatan 14  
 416 70 Göteborg  
 Tfn: +46 31 19 56 00  
 Fax: +46 31 19 77 90

Settings	Valve settings ppm:15.0 t:000s	Valve settings ppm: <u>1</u> 5.0 t:000s
To enter the "settings" submenus press ENTER. Press PLUS to go to next menu or MINUS to go to previous.	Valve settings menu show the values set for Alarm 1 (valve control). There are two editable values, the ppm limit ("ppm:") and the time delay ("t:") of the alarm.  Press ENTER to edit the valve settings (se right). Press PLUS to go to next submenu and ABORT to exit the submenu.	Move cursor by pressing ENTER. Increase/decrease value by pressing PLUS/MINUS. Commit value by pressing LONG_ENTER. Abort edit by pressing ABORT.
	Alarm settings ppm:15.0 t:010s	Alarm settings ppm: <u>1</u> 5.0 t:010s
	Alarm settings menu show the values set for Alarm 2 (annunciation). There are two editable values, the ppm limit ("ppm:") and the time delay ("t:") of the alarm.  Press ENTER to edit the alarm settings (se right). Press PLUS to go to next submenu or MINUS to go to previous. Press ABORT to exit the submenu.	Move cursor by pressing ENTER. Increase/decrease value by pressing PLUS/MINUS. Commit value by pressing LONG_ENTER. Abort edit by pressing ABORT.

**Brännströms Elektronik AB**

Uddevallagatan 14  
416 70 Göteborg  
Tfn: +46 31 19 56 00  
Fax: +46 31 19 77 90

	Autoflush ( on) t:20s int:24h	Autoflush ( on) t:20s int:24h
	<p>Autoflush lets the user set the duration ("t:") in seconds and the interval ("int:") in hours of the automatic sensor flush function.</p> <p>Press ENTER to edit the autoflush settings (se right).</p> <p>Press PLUS to go to next submenu or MINUS to go to previous.</p> <p>Press ABORT to exit the submenu.</p>	<p>Move cursor by pressing ENTER. Increase/decrease value by pressing PLUS/MINUS. Commit value by pressing LONG_ENTER.</p> <p>Abort edit by pressing ABORT.</p> <p>Setting the duration to 0 seconds turns the autoflush feature off.</p>
	Set clock: 050327 11:34:05	Set clock: 050327 11:34:05
	<p>Set clock shows the date and time as displayed in the main menu.</p> <p>Press ENTER to edit/set the date and time.</p> <p>Press PLUS to go to next submenu or MINUS to go to previous.</p> <p>Press ABORT to exit the submenu.</p>	<p>Move cursor by pressing ENTER. Increase/decrease value by pressing PLUS/MINUS. Commit value by pressing LONG_ENTER.</p> <p>Abort edit by pressing ABORT.</p> <p>Time format is "yymmdd hh:mm:ss".</p>
	Curro mode 0 to 20 mA	Curro mode 0 to 20 mA
	<p>Curro mode shows the set mode of the current output.</p> <p>Press ENTER to edit/set the mode.</p> <p>Press PLUS to go to next submenu or MINUS to go to previous.</p> <p>Press ABORT to exit.</p>	<p>Toggle value by pressing PLUS/MINUS. Commit value by pressing LONG_ENTER.</p> <p>Abort edit by pressing ABORT.</p>

**Brännströms Elektronik AB**

Uddevallagatan 14  
416 70 Göteborg  
Tfn: +46 31 19 56 00  
Fax: +46 31 19 77 90



	Curro 20mA cal. 59100	Curro 20mA cal. 59 <u>1</u> 00
	<p>This menu lets the user change the calibration of the current output port. Press ENTER to edit/set the calibration value. Press PLUS to go to next submenu or MINUS to go to previous. Press ABORT to exit the submenu.</p>	<p>Measure the output using a ampere-meter and adjust the output to 20mA by pressing PLUS/MINUS. Commit value by pressing LONG_ENTER. Abort edit by pressing ABORT.</p>



**Brännströms  
Elektronik AB**

**Brännströms Elektronik AB**

Uddevallagatan 14  
416 70 Göteborg  
Tfn: +46 31 19 56 00  
Fax: +46 31 19 77 90

*info@brannstrom.se ♦ www.brannstrom.se*

## 10. Simulation

By holding the ENTER button pressed while in *main menu* lets the user simulate different ppm values and separator input states. In this mode the The following table shows the display in the simulation mode.

<pre>Simulation   SPL PPM=03.0 SEP ON</pre>		
<p>Pressing the MINUS button decreases the PPM value by 1.0. Pressing the PLUS button increases the PPM value by 1.0. Pressing the ABORT button toggles the simulated separator input (SEP_OFF = separator off, SEP_ON = separator on). In the upper right corner of the display an indication is given of the clean water valve position.</p>		

## 11. Contrast

By holding the ABORT button pressed while in *main menu* lets the user set the contrast of the LCD screen. The following table shows the display when as seen when adjusting the contrast.

<pre>Contrast: 010%</pre>		
<p>Pressing the MINUS button decreases the contrast value by 10%. Pressing the PLUS button increases the contrast value by 10%.</p>		



### Brännströms Elektronik AB

Uddevallagatan 14  
416 70 Göteborg  
Tfn: +46 31 19 56 00  
Fax: +46 31 19 77 90

## 12. Automatic stopping device test

### 12.1. While separator is active.

If the separator is active and the automatic stopping device is not activated (overboard valve open) it is possible to force the activation of the stopping device for a short period of time (10 s) by pressing LONG\_ENTER in the *main menu*. This allows testing that the automatic is correctly connected.

### 12.2. While separator is not active.

To check that the automatic stopping device is correctly connected see chapter “13.2.Step 2”.

## 13. Response test

### 13.1. Step 1

To check that the sensor responds to objects in the measuring path unscrew the cleaning cap (top of SENSOR housing) and insert a long plastic rod or something similar into the measuring path. **Do not** use anything that might scratch or in other ways damage the glass tube inside the SENSOR housing (as for example screwdrivers). If the sensor is working properly the display should read “PPM>30.0” (main menu). Note that the air-detection feature of the SENSOR requires the glass tube to be filled with water during this test for it to work.

### 13.2. Step 2

Testing alarms and valves are done in simulation mode (see “10. Simulation”) or in the “Test outputs” submenu of the *cleaning & test* menu (see page 22) since this doesn't require opening the MASTER housing.

### 13.3. Alternative

To make step 1 of the response test affect alarms and valves the apparatus needs to be active. Bilgmon 488 is activated (flashing green led) when in main menu and the separator input signal is active. Activation can be done by strapping connections 10 and 11 (see “Electrical connections”). This method is **not recommended** since there is an obvious risk of forgetting the strap and that it requires opening the MASTER unit.



#### Brännströms Elektronik AB

Uddevallagatan 14  
416 70 Göteborg  
Tfn: +46 31 19 56 00  
Fax: +46 31 19 77 90

## 14. Calibration check (40 NTU)

Enter the "Check 40NTU cal" submenu of the *cleaning & test* menu (see page 21). Press enter to start the calibration test. The clean water valve will now be opened. Close the clean water supply. Drain the sensor and fill it with 40NTU calibration fluid. The display should now show a value between 80% and 100%. If this is the case an "OK" will be shown over the RETURN button. Press the RETURN button to set the "Cal checked" date as shown in the "Sensor info" submenu.



### **Brännströms Elektronik AB**

Uddevallagatan 14  
416 70 Göteborg  
Tfn: +46 31 19 56 00  
Fax: +46 31 19 77 90

[info@brannstrom.se](mailto:info@brannstrom.se) ♦ [www.brannstrom.se](http://www.brannstrom.se)

## 15. Log entries

The following entries are stored in the log of BilgMon488:

<i>Type</i>	<i>Example</i>	<i>Explanation</i>
POWER ON	Log: POWER ON 060102 11:36:32	Power was turned on at given date and time (yymmdd hh:mm:ss).
POWER OFF	Log: POWER OFF 060102 14:06:10	Power was turned off.
SEP ON	Log: SEP ON 060102 12:10:12	Separator signal input turned from not activated to activated.
SEP OFF	Log: SEP OFF 060102 12:23:34	Separator signal input turned from activated to not activated.
PPM ABOVE	Log: PPM > 15 060102 12:15:13	Measured ppm went from below set valve ppm level to above (in example valve setting is 15 ppm).
PPM BELOW	Log: PPM < 15 060102 12:17:42	Measured ppm went from above set valve ppm level to below (in example valve setting is 15 ppm).
PPM SET	Log: PPM SET 05 060102 13:10:07	Valve ppm level setting was changed to indicated value (in example to 5 ppm).
SIM ON	Log: SIM ON 060102 12:09:50	Simulation was turned on.
SIM OFF	Log: SIM OFF 060102 12:24:19	Simulation was turned off.
TIME SET	Log: TIME SET +0:59:46	Clock was altered (in settings menu). Offset to BilgMon builtin realtime clock in hours, minutes and seconds is shown.
RTC SET	Log: RTC SET 051021 09:47:29	BilgMon builtin realtime clock was set (logged once at factory).
PPM AVG	Log: PPM AVG 04 051021 09:47:29	PPM average when below set valve ppm limit since latest SEP ON signal.



### Brännströms Elektronik AB

Uddevallagatan 14  
416 70 Göteborg  
Tfn: +46 31 19 56 00  
Fax: +46 31 19 77 90

info@brannstrom.se ♦ www.brannstrom.se

## 16. Maintenance

The BilgMon488 can be set to autoflush (see page 24). This means that the sensor tube is flushed with clean water at durations and intervals as set in the settings menu. Autoflush is only active when in main menu and BilgMon488 is not active.

Cleaning the measurement unit should be done using a soft bottle-brush and mild detergent. Note that there is a glass tube inside the SENSOR unit so don't use anything that might scratch or damage the glass (i.e. metal objects). If the glass tube is layered with rust or similar try using low concentrated acid (for example hydrochloric acid). Rinse well and make sure you protect your eyes, skin and airways if using acidic substances.



### **Brännströms Elektronik AB**

Uddevallagatan 14  
416 70 Göteborg  
Tfn: +46 31 19 56 00  
Fax: +46 31 19 77 90

*info@brannstrom.se ♦ www.brannstrom.se*

## 17. Spare parts list

See drawing BM201001A (next page).

<i>Description</i>	<i>Order nr.</i>
Sensor unit	BM201001A-1
Master unit	BM201001A-2
Magnetic valve assembly	BM201001A-3
Calibration check kit, comprising: <ul style="list-style-type: none"> <li>• Cleaning brush</li> <li>• Syringe</li> <li>• Bottle 500 ml with lid</li> <li>• Bottle 50 ml, calibration check liquid.</li> <li>• Instructions</li> <li>• Cleaning cap</li> </ul>	BM201001A-4



### **Brännströms Elektronik AB**

Uddevallagatan 14  
416 70 Göteborg  
Tfn: +46 31 19 56 00  
Fax: +46 31 19 77 90

[info@brannstrom.se](mailto:info@brannstrom.se) ♦ [www.brannstrom.se](http://www.brannstrom.se)

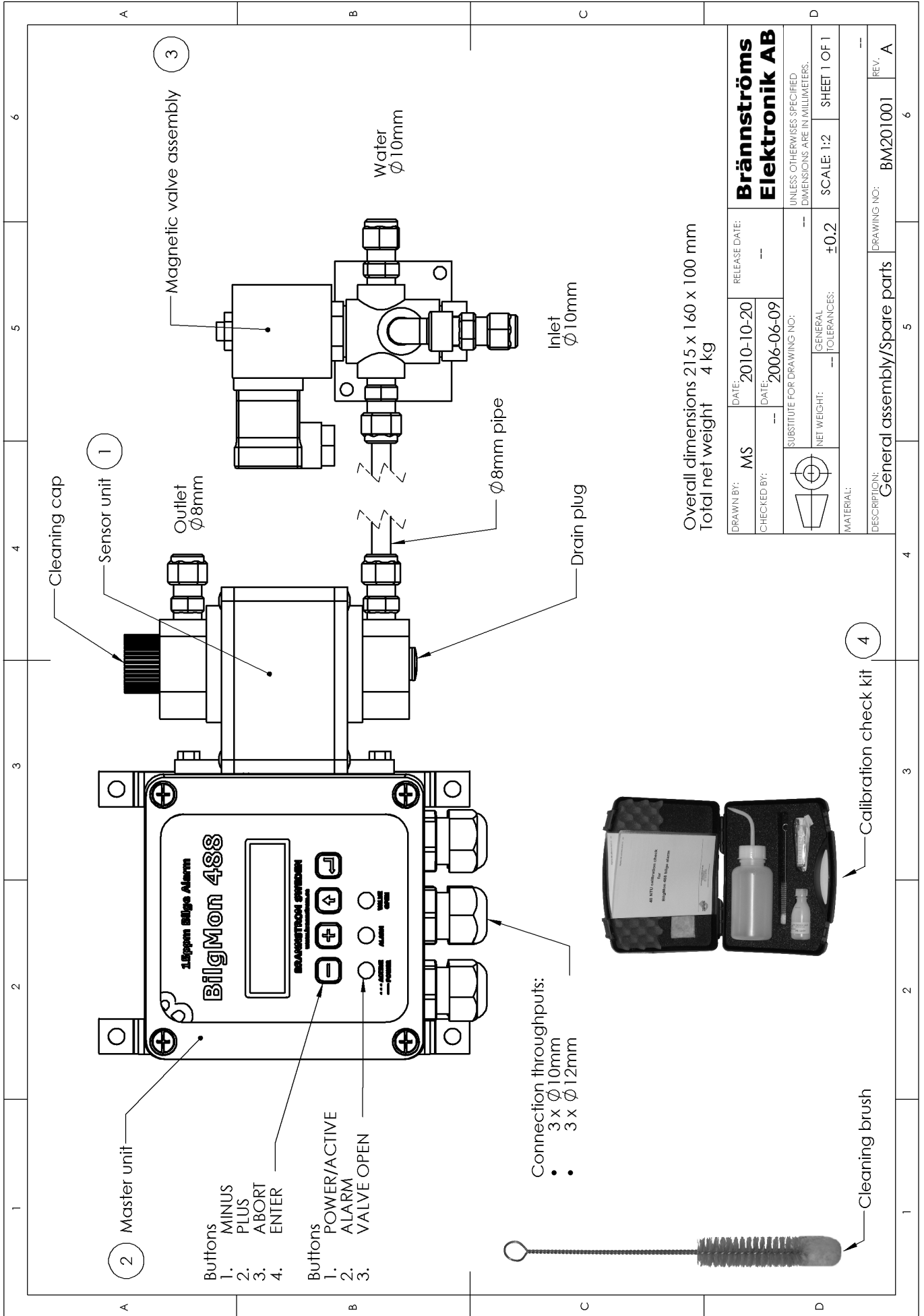

DATE: 2010-10-20	RELEASE DATE: --	<b>Brännströms Elektronik AB</b>	
CHECKED BY: MS	DATE: 2006-06-09	UNLESS OTHERWISE SPECIFIED DIMENSIONS ARE IN MILLIMETERS.	
SUBSTITUTE FOR DRAWING NO:		NET WEIGHT: --	GENERAL TOLERANCES: ±0.2
DRAWING NO: BM201001		SCALE: 1:2	SHEET 1 OF 1
DESCRIPTION: General assembly/spare parts		MATERIAL: --	
REV: A		DRAWING NO: BM201001	

THE INFORMATION CONTAINED IN THIS DRAWING IS THE SOLE PROPERTY OF BRÄNNSTRÖMS ELEKTRONIK AB. ANY REPRODUCTION IN PART OR AS A WHOLE WITHOUT THE WRITTEN PERMISSION OF BRÄNNSTRÖMS ELEKTRONIK IS PROHIBITED.



## 18. Troubleshooting

<i>Symptom</i>	<i>Possible reason</i>	<i>Servicing</i>
BilgMon488 is switched on but LCD remains blank.	Power supply is erroneous.  or  LCD monitor is broken.  or  Automatic fuses blown.	Check connections internally, externally and power supply voltages.    Order replacement part.   Disconnect externals that might have caused the short-circuit (f.ex. water/sample-valve). Wait until fuses have cooled down power up the unit again.
PPM value remains high	Dirty sensortube  or  Air present in sample  or  Excessive contaminates present in sample (rust, bacteria etc...)	Clean the sensor tube and re-zero.   Correct cause of air presence. Clean sensor and re-zero.   Correct cause of contamination. Clean sensor and re-zero.
LCD display show: MEMORY ERROR, MEMORY WRITE ERROR, ERASE ERROR	Memory malfunction  or  Memorychip not present	Order replacement part.   Order replacement part.

<i>Symptom</i>	<i>Possible reason</i>	<i>Servicing</i>
LCD display show: Lost sensor com!	Dirty or damaged MASTER-SENSOR contact area.	Part MASTER and SENSOR units. Clean contact surface with mild detergent.
LCD display show: RTC check: FAILED!	Real time clock stopped.	Order replacement part.